

# **STUDĒJOŠO ZINĀTNISKI PĒTNIECISKO RAKSTU KRĀJUMS**

**Sējums 1**

**MAĢISTRA STUDIJU PROGRAMMAS:**

**Biznesa vadība**

**Business administration**

**Rīga 2024**



## **Studējošo zinātniski pētniecisko rakstu krājums, 2024(1)**

ISSN 2500-976; e-ISSN 2500-977X

Studējošo zinātniski pētniecisko rakstu krājumā ir iekļauti Ekonomikas un kultūras augstskolas (EKA) un Alberta koledžas (AK) studējošo un absolventu valsts pārbaudījuma darbu fragmenti, kā arī EKA, AK un citu augstskolu studējošo zinātniskie raksti, kas tika iesniegti uz **Studentu starptautisko zinātniski praktisko konferenci „Studējošo pētnieciskā darbība: teorija un prakse’2024”**.

Sējumā ir iekļauti raksti, kuros ir atspoguļoti Ekonomikas un kultūras augstskolas maģistra programmu „Biznesa vadība“ un „Business administration“ studējošo veikto pētījumu rezultāti.

### **Rakstu krājuma galvenā redaktore:**

Jeļena Titko / Ekonomikas un kultūras augstskola

### **Rakstu krājuma tehniskā redaktore:**

Kristīne Užule / Ekonomikas un kultūras augstskola

© Ekonomikas un kultūras augstskola, 2024

© Alberta koledža, 2024

### **Izdevējs:**

Ekonomikas un kultūras augstskola

Pērnavas 62, Rīga, LV1009, Latvija



## Saturs

<b>BIZNESA VADĪBA.....</b>	<b>4</b>
Laura Strazdiņa. LATVIJAS NEBANKU KREDITĒŠANAS SEKTORA UZŅĒMUMU PELNĪTSPĒJU IETEKMĒJOŠIE FAKTORI.....	5
Līga Prancāne. AUTOMATIZĀCIJAS PROCESU IETEKME UZ GRĀMATVEDĪBAS PROCESU KVALITĀTES UZLABOŠANU LATVIJAS UZŅĒMUMOS .....	18
Rita Vidže. KORPORATĪVĀS SOCIĀLĀS ATBILDĪBAS IETEKME UZ KLIENTU LOJALITĀTI MAZUMTIRDZNIECĪBAS UZŅĒMUMOS LATVIJĀ .....	31
Zita Draveniece. DARBINIEKU APMIERINĀTĪBU IETEKMĒJOŠIE FAKTORI PAKU SŪTĪJUMU NOZARĒ LATVIJĀ .....	42
Nauris Sedlers. INTEGRĒTĀS VADĪBAS SISTĒMAS PAPLAŠINĀŠANAS IESPĒJAS NODROŠINOT ATBILSTĪBU JAUNAM STANDARTAM UZŅĒMUMĀ "INTERLUX" .....	50
Elvita Ērgle. RISK MANAGEMENT PROCESSES IN INTERNATIONAL PROJECT EXPEDITIONS.....	59
<b>BUSINESS ADMINISTRATION: Ārzemju studentu sekcija.....</b>	<b>67</b>
Dmitriy Ivanchenko. CHALLENGES AND SOLUTIONS FOR LATVIAN SMALL AND MEDIUM ENTERPRISES IN SUSTAINABILITY REPORTING.....	68
Gaurav Prakash. FEMALE FETICIDE IN INDIA.....	75
Madushani Saumya Jayarathne, Ikkagoda Arachchige. FACTORS AFFECTING STAFF TURNOVER IN THE APPAREL SECTOR IN SRI LANKA .....	81
Ambuja Bangalore Srinivasa. GUIDELINES FOR DEVELOPMENT OF STRATEGY FOR GLOBAL COMPETITIVE ADVANTAGE OF LATVIAN COSMETIC COMPANIES .....	88
Dhanush Priyan Mahesh. FACTORS AFFECTING CUSTOMER SATISFACTION IN THE LATVIAN HOTEL INDUSTRY .....	98
Ushan Eranga Dissanayake. IMPACT OF ADVERTISING APPEALS ON IMPULSIVE PURCHASING FOR CONSUMER DURABLES IN WESTERN PROVINCE IN SRI LANKA .....	108
Nimesha Harshani Gunawardhana Asuramana Pedige. CONSUMERS' ATTITUDE TOWARDS GREEN PACKAGING: EVIDENCE FROM FOOD AND BEVERAGE INDUSTRY IN SRI LANKA .....	115
Shimashi Niranthara Samarasekara Naiduwadura. E-COMMERCE STRATEGIES FOR SMALL AND MEDIUM ENTERPRISES IN SRI LANKA.....	122
Aswathy Levan. ASSESSMENT OF RELATIONSHIP MARKETING AS A TOOL TO IMPROVE THE COMPETITIVENESS OF LATVIAN WOOD SELLING COMPANIES .....	129



# **BIZNESA VADĪBA**



## Laura Strazdiņa. LATVIJAS NEBANKU KREDITĒŠANAS SEKTORA UZŅĒMUMU PELNĪTSPĒJU IETEKMĒJOŠIE FAKTORI

*Ekonomikas un kultūras augstskola  
Maģistra studiju programma "Biznesa vadība"  
E-pasts: laura.strazdina999@inbox.lv  
Zinātniskais vadītājs: Dr. oec., profesore Jeļena Titko*

### Anotācija

**Pētījuma aktualitāte:** Pēc Patērētāju tiesību un aizsardzību centra (turpmāk tekstā PTAC) jaunākajiem datiem, kredītu apjoms arvien pieaug un uzņem popularitāti. Pieaug tieši kredīta apjoms, nevis skaits. Kredītu skaitliskais daudzums ir samazinājies, salīdzinājumā ar iepriekšējiem gadiem, taču izsniegtais naudas apjoms ir lielāks, kā iepriekšējos gados. (PTAC, 2023) Tas norāda uz to, ka cilvēki sākuši kredītos ņemt lielākas summas nekā iepriekš, ņemot patērīga kredītus lielākiem mērķiem, tādiem kā auto iegādei, remontam, ceļojumiem utt. Tādējādi, izsniedzot kredītus, kredītiestāde uzņemas lielākus riskus un potenciālos zaudējumus. Tāpat arī pēc PTAC datiem, kredītdevēju skaits nebanku sektorā turpina samazināties, līdz ar ko esošie uzņēmumi saskaras arvien pieaugušu pieprasījumu, līdz ar ko ir rūpīgāk jāizvērtē kredītu izsniegšana.

**Pētījuma mērķis:** Noteikt Latvijas nebanku kreditēšanas sektora uzņēmumu pelnītspēju ietekmējošus faktorus.

**Pētījuma metodes:** Tika veikta literatūras analīze, ar mērķi izprast pelnītspējas jēdzienu. Potenciāli peļņu ietekmējošus faktorus autore identificēs ar sekundāro datu analīzi, pētot jau esošus rakstus par uzņēmumu pelnītspēju. Darba autore veiks dokumentu analīzi ar mērķi apskatīties esošos finanšu rādītājus un veiks finanšu koeficientu aprēķināšanu. Datu apstrādei tiks izmantotas sekojošas metodes: grafiskā analīze, finanšu koeficientu aprēķināšana, korelācijas analīze, daudzfaktoru lineārās regresijas analīze

**Sasniegtie rezultāti:** Darba gaitā tika identificēti un galvenie Latvijas nebanku kreditēšanas sektora uzņēmumu pelnītspēju ietekmējošie faktori un tika izpētīta katra faktora ietekme uz uzņēmumu darbību.

*Atslēgas vārdi: kredīts; pelnītspēja; peļņa; kredītiestādes.*

### Ievads

Katra uzņēmuma viens no prioritārākajiem mērķiem ir naudas pelnīšana. Bez naudas pelnīšanas uzņēmums nevarēs nodrošināt savu darbību. Taču, uzņēmēji vēlas ne tikai nopelnīt naudu lai nosegtu visas darbības izmaksas, bet arī gūt peļņu uzņēmuma tālākai attīstībai. Pelnītspēja ir svarīgs faktors, kurš katram uzņēmumam ir strikti jāuzrauga. Ir vairāki finanšu dokumenti, kuri norāda uz uzņēmuma finansiālo stāvokli, taču ne vienmēr ir skaidra uzņēmuma darbības efektivitāte apskatot tikai bilanci vai, piemēram, gada pārskatu. Tādēļ ir izveidoti vairāki finanšu koeficienti, ar kuru aprēķināšanu ir iespējams uzzināt vai uzņēmums ir pelnītspējīgs vai nē.

Īpaši svarīgi ir pelnītspēju uzraudzīt uzņēmumos, kur ienākumi tiek gūti tikai pēc pakalpojumu sniegšanas. Kreditēšanas uzņēmumi tiek pieskaitīti pie šīs uzņēmumu grupas, jo sākotnēji tiek izsniegts kredīts un tikai pēc tam uzņēmums gūs peļņu no procentu maksājumiem. Tiek lēsts, ka kredītiestādes

21. gadsimtā ir viens no galvenajiem finanšu tirgus centriem, kas regulē, stimulē, apgrūtina un piedāvā dažādus pakalpojumus tautsaimniecību tirgus starpniekiem mājsaimniecībām, uzņēmumiem, ārzemniekiem. (Saksonova, 2006) Latvijā pieprasījums pēc kredītiem turpina augt. 2023.gada 1. pusgadā raksturojas ar rekordlielu jaunu aizdevumu izsniegšanu kā mēnešu griezumā, tā kopumā pusgadā. 2023.gada 1. pusgadā mazākā kopējā izsniegtā aizdevumu summa bija februārī – 54,17 milj. EUR, savukārt aprīlī sasniedza 65,68 milj. EUR vienā mēnesī. (PTAC, 2023.) Tā kā pieprasījums pēc aizdevumiem būtiski pieaug, aizdevējiem ir atbildīgi jāizsniedz aizdevumi, lai nerastos situācijas, ka aizdevumi pieaug neproporcionāli peļņai.

Pētījuma objekts ir Latvijas nebanku kreditēšanas sektora uzņēmumi. Pētījuma priekšmets ir Latvijas nebanku kreditēšanas sektora uzņēmumu pelnītspējas prognozēšana. Zinātniskā darba mērķis Identificēt Latvijas nebanku kreditēšanas sektora uzņēmumu pelnītspēju ietekmējošus faktorus. Lai sasniegtu darba mērķi ir izvirzīti šādi uzdevumi:

- Teorētiski izpētīt pelnītspējas jēdzienu un ar to saistītās koncepcijas.
- Veikt Latvijas nebanku kreditēšanas sektora analīzi.
- Noteikt finanšu kreditēšanas sektora uzņēmumu pelnītspēju ietekmējošus faktorus. Veikt Latvijas nebanku kreditēšanas sektora uzņēmumu finanšu analīzi.
- Veikt korelācijas analīzi, lai izprastu finanšu koeficientu sakarību ar uzņēmuma pelnītspējas rādītāju.
- Veikt regresijas analīzi ar mērķi izveidot pelnītspējas prognozēšanas modeli.

Balstoties uz darba mērķi un izvirzītajiem uzdevumiem, tiek izvirzīts viens pētījuma jautājums: Kādi faktori ietekmē pelnītspēju Latvijas nebanku kreditēšanas sektorā strādājošajiem uzņēmumiem? Datu vākšanas metodes aptvēra literatūras analīzi, mediju monitoringu, dokumentu analīzi (finanšu pārskatu analīzi), un statistikas analīze. Datu apstrādes metodes aptvēra grafisko analīzi, finanšu koeficientu aprēķināšanu, korelācijas analīze, kā arī daudzfaktoru lineārās regresijas analīzi.

Pētījuma ietvaros tika identificēti šādi novitātes elementi:

- Tika identificēti un aprakstīti finanšu uzņēmumu pelnītspēju ietekmējošie iekšējie faktori un rādītāji, ar kuru palīdzību būtu iespējams novērtēt faktorus;
- Tika izstrādāts lineārās regresijas modelis pelnītspējas prognozēšanai vairākiem uzņēmumiem atsevišķi un kopā pa visiem analizējamajiem uzņēmumiem.

Zinātniskā darba pētījuma ierobežojumi ir:

- Lai analizētu uzņēmumu pelnītspējas dinamiku darba autore rēķināja tikai vienu koeficientu – aktīvu rentabilitāte ROA.
- Saistībā ar darba apjoma un pētījuma laika ierobežojumu, tika apskatīti tikai iekšējie finanšu rādītāji, netika ņemti vērā iekšējie pelnītspēju ietekmējošie faktori.
- Korelācijas un daudzfaktoru lineārās regresijas analīze tika veikta 7 uzņēmumiem laika periodā no 2014. gada līdz 2022. gadam un dažiem uzņēmumiem periodā no 2015. g. līdz 2022. g.
- Pētījuma periods: 2024. gada februāris – maijs.

## Analītiskais apskats

Katram uzņēmumam var būt dažādi mērķi, dažādas vīzijas un misijas un tie var kardināli atšķirties viens no otra. Taču, katram uzņēmumam ir kopīgs tas, ka lai tas varētu pastāvēt ilgtermiņā, tam ir jāpelna nauda, jābūt pelnītspējīgam. Pelnītspēja ir uzņēmuma spēja gūt ienākumus attiecībā pret izdevumiem. Ja uzņēmuma ieņēmumu pieaugums pārsniedz tā izdevumus un darbības izmaksas, tas tiek uzskatīts par pelnītspējīgu. Uzņēmumi, kas nepelna pietiekami daudz naudas, tiek uzskatīti par nerentabliem, un tiem ir jāveic korekcijas, lai atkal kļūtu pelnītspējīgi. (Fredriksson, 2020)

Katram strādājošam uzņēmuma ir liels faktoru skaits, kas var ietekmēt peļņu. Faktorus var iedalīt divās grupās:

- Iekšējie faktori – tie ir tie faktori, kurus uzņēmums var ietekmēt, kā, piemēram, ražošanas izmaksas, darbaspēka izmaksas utt;
- Ārējie faktori – tie faktori, kas nāk no uzņēmuma ārpusē, kurus uzņēmums ietekmēt nevar, piemēram, nodokļu politikas izmaiņas, normatīvo aktu izmaiņas utt.

Lai noteiktu vai uzņēmums ir pelnītspējīgs, var izmantot vairākus rādītājus. Viens no rādītājiem, kas parāda vai uzņēmums gūst peļņu, ir rentabilitāte. Rentabilitātes rādītājus var iedalīt trīs grupās: komerciālā rentabilitāte, ekonomiskā (aktīvu) rentabilitāte, un finansiālā (pašu kapitāla) rentabilitāte. (Saksonova, 2012)

### Latvijas nebanku kreditēšanas sektors

Banku nozare ir viena no svarīgākajām jebkuras ekonomikas sastāvdaļām un galvenais ekonomikas izaugsmes virzītājspēks. Viena no galvenajām banku funkcijām ir kredītu izsniegšana uzņēmumiem un patērētājiem, kas palīdz finansēt jaunas investīcijas un stimulē pieprasījumu ekonomikā (CRIF Digital, 2022). Lai gan augstāk minēts par banku nozarē pastāvošiem uzņēmumiem, banku un nebanku kreditēšanas nozarei ir daudz kopīgu iezīmju, kas ļauj tās salīdzināt un attiecināt vienai uz otru. Galvenā atšķirība ir tāda, ka bankas piedāvā ne tikai kreditēšanas pakalpojumus, bet arī noguldījumu iespējas, debitkaršu un maksājuma kontu iegāde, noguldījumus pensiju līmenī utt., bet nebanku patērētāju kreditēšanas nozarē galvenais peļņas gūšanas veids un lielākais uzsvars tiek likt uz patērētāju kreditēšanu (gan fiziskas, gan juridiskas personas).

Nebanku patērētāju kreditēšanas sektorā darbojās galvenokārt kredītiestādes. “Kredītiestāde - Latvijas Republikā, citā dalībvalstī vai trešajā valstī reģistrēta kredītiestāde vai dalībvalsts, trešās valsts kredītiestādes filiāle vai pārstāvniecība” (Latvijas Republikas Saeimas un Ministru Kabineta Ziņotājs, 2008). Nebanku kreditēšanas sektorā, atšķirībā no banku sektora, uzņēmumu galvenais peļņas gūšanas veids ir kredītu izsniegšana un peļņa no procentu maksājumiem. “Kredīts - atlīdzības darījums, kurā kredītiestāde uz rakstveida līguma pamata nodod klientam naudu vai citas lietas īpašumā un kurš klientam uzliek pienākumu noteiktā laikā un kārtībā atdot kredītiestādei naudu vai citas lietas” (Kredītiestāžu likums, 1995). “Nebanku patēriņa kreditēšanas nozares pienesums valsts kopbudžetā 2022. gadā bija vairāk nekā 26,89 milj. eiro, un šobrīd nozarē kopā tiek nodarbināti vairāk nekā 1300 darbinieku” (Sauka, 2023).

Latvijas nebanku kreditēšanas nozares uzņēmumu populārākie produkti ir patēriņa kredīts, distances kredīts, auto līzings vai auto kredīts, hipotekārie kredīti, kredīts pret nekustamā īpašuma ķīlu. Nebanku kreditēšanas nozarei ir tendence augt. Arī 2023. gada pirmajā pusgadā bija vērojams pieaugums no jauna izsniegto kredītu summās salīdzinot ar 2022. gadu (sk. 1. tabulu). “2023. gads banku sektoram viennozīmīgi bija rekordpeļņas gads. 2023. gadā kredītiestāžu pārskata gada peļņa strauji pieauga un sasniedza 607 milj. eiro – absolūtā izteiksmē tā bija lielākā gada laikā gūtā peļņa” (Makroekonomika.lv 2024).

**1. tabula.** No jauna izsniegto aizdevumu skaita un apjoma izmaiņas 2022-2023.gadu 1.pusgadā (Avots: PTAC, 2023)

Kredīta veids	2022. gada pirmais pusgads		2023. gada pirmais pusgads		2023.gada 1.pusgadā salīdzinājumā ar 2022.gada 1.pusgadu	
	Summa, EUR	Kredītu skaits	Summa, EUR	Kredītu skaits	Summas izmaiņas, %	Kredītu skaita izmaiņas, %
Distances kredīts	133344847	198645	166229920	203473	24,66	2,43
Patēriņa kredīts	56438051	77610	59663637	69670	5,72	-10,23
Līzings, noma un citi ar TL nodrošināti kredīti	100679864	6065	105867501	5677	5,15	-6,40
Hipotekārie kredīti	4924966	296	6124480	314	24,36	6,08
Kredīti pret kustamas lietas ķīlu	16390542	171489	20671438	192792	26,12	12,42
Nebanku sektors kopā	311778270	454105	358556975	471926	15,00	3,92

Statistika rāda, ka no jauna izsniegto kredītu summārais skaits ir palielinājies. Kopumā tas pieauga par 15% jeb par 46 778 705 eur tika izsniegts vairāk kredītos nekā 2022. gada pirmajā pusgadā. Taču, kredītu skaits nav tik daudz pieaudzis, kas norāda uz tendenci, ka cilvēki sākuši ņemt kredītos lielākas summas nevis vairāk kredītus (sk. 1. tabulu).

Lielāka kredīta summa norāda uz to, ka kredītiestādēm rodas lielāks risks saistīts ar to, ka klients ar laiku mainīs maksāšanas paradumus un sliktāk maksās kredītu, jo jo ilgāks ir kredīta termiņš, jo grūtāk prognozējama nākotnes maksāšanas spēja. Taču ir arī pozitīvas iezīmes tam, ka palielinās kredīta summas – procentu maksājums ir lielāks, līdz ar ko, kredītiestādes gūst lielāku peļņu.

Analizējot esošo informāciju, darba autore secina, ka uz doto brīdi Latvijā nebanku kredītēšanas nozare piedzīvo uzplaukumu. Liels pieprasījums pēc kredītiem no patērētāju puses, iespēja piedāvāt aizdevumus uz augstākām procentu likmēm un saistībā ar to, ka konkurentu paliek arvien mazāk un konkurenci, kuri piedāvā aizdevumus ar salīdzinoši zemām procentu likmēm ir vēl mazāk, uzņēmumi saskaras ar lielu pieprasījumu, kura iespaidā var izvēlēties kādus patērētājus kreditēt un kādus nē.

### Pētījuma metodoloģija

Darba mērķis ir identificēt finanšu institūciju peļņu ietekmējošus faktorus. Apkopojot vairākus zinātniskos rakstus, darba autore veido rādītāju grupu, kuri, iespējams, ietekmē uzņēmumu pelnītspēju. Rādītāji ir apkopoti 2. tabulā.



**2.tabula.** Pelnītspēju ietekmējošo rādītāju apkopojums (Avots: autores apkopojums)

Rādītājs	Formula	Apzīmējums	Avots
Izmaksu un ienākumu attiecības koeficients (cost – to – income ratio - CIR)	$CIR = (\text{Darbības izdevumi}) / (\text{Pamatdarbības ienākumi}) * 100$	CIR	Azzabi & Lahrinchi (2023); Dembel (2020); Wagdi & Salman (2022)
Neto procentu marža (Net interest margin - NIM)	$NIM = (\text{tīro procentu ienākumi}) / (\text{kopējie aktīvi}) * 100$	NIM	Fibriyanti & Nurcholidah (2020); Wagdi & Salman (2022), Dembel (2020); Tmava et al. (2019)
Neto procentu ienākumi (Net interest income – NII)	Tīrie procentu ienākumi	NII	Dembel (2020); Wagdi & Salman (2022)
Pamatlīdzekļu apgrozījuma koeficients (Fixed asset turnover ratio - FAT)	$FAT = \text{Pamatlīdzekļi} / (\text{Kopējie aktīvi}) * 100$	FAT	Dembel (2020); Wagdi & Salman (2022)
Bezprocentu izdevumu attiecība pret bruto izdevumiem (Ratio of non-interest expenses to gross expenses - NEGRE)	$NEGRE = (\text{bezprocentu izdevumi}) / (\text{bruto izdevumi}) * 100$	Expenses	Dembel (2020); Wagdi & Salman (2022); Ngweshemi & Isiksal (2021)
Uzkrājumi kredīta zaudējumiem / Zaudējumiem / kopējie aizdevumi (Provisions for credit losses / total loans - PCLTL)	$PCLTL = (\text{Uzkrājumi kredīta zaudējumiem}) / (\text{Kopējie aizdevumi}) * 100$	PCLTL	Azzabi & Lahrinchi (2023); Wagdi & Salman (2022)
Aizņemtie līdzekļi	Debt = īstermiņa kreditori + ilgtermiņa kreditori	Debt	Hasna u.c. (2020); Ngweshemi & Isiksal (2021)
Parāda attiecība pret pašu kapitālu (Debt to equity ratio – DER)	$DER = (\text{Aizņemtais kapitāls}) / (\text{Pašu kapitāls}) * 100$	DER	Kawshala & Panditharathna (2017); Tmava et al. (2019);
Kopējie aktīvi	Aktīvi	Asset	Kawshala & Panditharathna (2017); Wagdi & Salman (2022)
Darbinieku skaits	Darbinieku skaits	Staff	Hasna u.c. (2020); Tmava et al. (2019)
Pašu kapitāla un aktīvu attiecības koeficients (Equity to Assets Ratio - EAR)	$EAR = (\text{pašu kapitāls}) / (\text{kopējie aktīvi}) * 100$	EAR	Kawshala & Panditharathna (2017); Dembel (2020); Wagdi & Salman (2022)
Gadi, cik strādā uzņēmums	Uzņēmuma vecums	Age	Dembel (2020); Tmava et al. (2019)



Darba autore izvēlējās uzņēmumus, kuriem rēķināt koeficientus un uzņēmumus izvēlējās pēc sekojošiem kritērijiem:

- Pieejams periods gada pārskatiem vismaz no 2015. gada;
- Galvenais peļņas gūšanas veids – kredītu izsniegšana;
- No gada pārskatos un to pielikumos esošās informācijas ir iespējams aprēķināt izvēlētos koeficientus.

Ņemot vērā šos kritērijus, autore izvēlējās septiņus uzņēmumus:

- SIA "OC Finance";
- SIA "Inbank Latvia";
- SIA "InCREDIT GROUP";
- AS "VIA SMS group";
- SIA "IPF Digital Latvia";
- SIA "Aizdevums.lv";
- AS "4finance".

Noslēdzošajā darba posmā darba autore veica daudzfunkcionālo regresijas analīzi. Sākotnēji autorei bija nepieciešams izvēlēties Y vērtības. Kā Y vērtības tiks izmantota aktīvu rentabilitāte (ROA). Aktīvu atdeve (ROA) jeb aktīvu rentabilitāte nav tieši atrodamā bilancē vai gada pārskatā, taču to var aprēķināt (1. formula). Aktīvu atdeves formula ir šāda:

$$\text{Aktīvu rentabilitāte, \%} = \frac{\text{Neto peļņa vai peļņa pirms procentu un nodokļu atskaitīšanas} \cdot 100}{\text{Aktīvu bilance}} \quad (1)$$

(Paupa & Šneidere, 2008, 12)

Darba autore, lai veiktu korelācijas analīzi un lineārās regresijas analīzi, izmantos SPSS rīku. Lineārās regresijas analīze tiks veikta ar "Stepwise" funkciju, lai vairākkārtīgi nepārbaudītu X un Y korelāciju.

Visu modeļu precizitāte tiks pārbaudīta izmantojot šādus testus:

- Koriģētais determinācijas koeficients (Adjusted R Square);
- F-testa statistiskais nozīmīgums (Sig.);
- Variances inflācijas faktora (Variance Inflation Factor VIF) analīze;
- Durbina-Vatsona (DW) autokorelācijas tests.

Adjusted R Square jeb koriģētais determinācijas koeficients raksturo, kādu daļu no kopējām Y variācijām izskaidro novērtētais regresijas vienādojums. F-testa statistiskais nozīmīgums (Sig.) attiecas uz statistikas metožu izmantošanu, ko izmanto, lai noteiktu, vai izlase, kas ņemta no kopas, patiešām ir no kopas vai arī pēc nejaušības faktora. Parasti statistisko nozīmīgumu nosaka iestatītais alfa līmenis, kas parasti tiek iestatīts uz 0.05. Secinošā statistika nodrošina veiktās analīzes testa statistiku un nozīmīguma līmeni, un, ja saistītā vērtība (vai nozīmīguma) vērtība nokrītas zem noteiktā alfa līmeņa, tad analīzi var uzskatīt par statistiski nozīmīgu. (Statistics Solutions, n.d.).

Variances inflācijas faktora (Variance Inflation Factor VIF) norāda uz to, vai nepastāv multikolinearitātes problēma. “Multikolinearitātes vai vienkārši kolinearitātes problēma var parādīties katrā daudzfaktoru regresijas modelī, jo nosakot regresiju starp Y un dažādiem izskaidrojošiem mainīgajiem, jāņem vērā arī tas, vai nepastāv kaut kādas sakarības (attiecības) starp pašiem mainīgajiem.” (Jansons & Kozlovskis, 2012, 211).

Ja starp mainīgo  $x_i$  un citiem mainīgajiem nebūtu kolinearitātes, tad VIF būtu vienāds ar 1. Bet tas ir tikai ideāls stāvoklis. Parasti, starp dažiem neatkarīgiem mainīgajiem vienmēr pastāv zināma kolinearitātes pakāpe. Palielinoties lineārajai attiecībai starp mainīgajiem, pakāpeniski palielinās VIF. Kas nozīmē to, ka jo lielāks ir VIF, jo nopietnāka ir mainīgo multikolinearitātes. Ja VIF ir lielāks par 10, pastāv multikolinearitāte. (Cheng et al., 2022) Darba autore regresijas analīzē pielietoja Durbina Vatsona (DW) autokorelācijas testu. Darbā tika izmantota interneta vietnē atrodamā DW augšējo un apakšējo kritisko vērtību tabula.

## Pētījuma rezultāti

Zinātniskā darba ietvaros, darba autore apskatīja un finanšu koeficientus rēķināja septiņiem nebanku kredītēšanas sektorā strādājošiem uzņēmumiem. Darba autore, kā y rādītāju regresijas analīzei izvēlējās rēķināt ROA (aktīvu rentabilitāte) rādītāju (sk. 1. att).



**1. attēls.** Aktīvu rentabilitātes koeficienta izmaiņas kreditoriem 2014. – 2022. gads (Avots: autores apkopojums)

Ir redzams, ka uzņēmumu ROA rādītāji ir ļoti nepastāvīgi (sk. 1.att.). Tādas aktīvu rentabilitātes svārstības norāda uz to, ka uzņēmumam ir jāveic finanšu analīze, lai diagnosticētu potenciālas problēmas. Svārstības norāda uz to, ka, iespējams, jāpārskata uzņēmuma esošie aktīvi un vai tie visi nes uzņēmuma peļņu, iespējams nepieciešams optimizēt aktīvu struktūru. Iespējams, uzņēmumam rodas kādas neparedzētas izmaksas vai tās strauji tiek palielinātas.

Aprēķinot un analizējot septiņu uzņēmumu aktīvu rentabilitātes rādītājus, darba autore secina, ka nozarē nav kaut kādu kopīgu tendenču, kā rezultātā visiem uzņēmumiem palielinātos vai samazinātos ROA koeficients. Atšķirīgs aktīvu rentabilitātes koeficients starp uzņēmumiem, kuri strādā vienā un tajā pašā nozarē, varētu norādīt uz to, ka visi uzņēmumi izmanto dažādus uzņēmumu darbības modeļus peļņas gūšanā, piemēram, viens uzņēmums var izvēlēties kreditēt vairāk riskantus klientus ar augstākām procentu likmēm, savukārt cits uzņēmums kreditēs ar zemākām procentu likmēm mazāk riskantus

klientus. Iespējams, uzņēmumi, kuri tirgū strādā jau vairākus gadus, ir sapratuši kā efektīvāk izmantot pārvaldībā esošos aktīvus, nekā uzņēmums, kas tikko vai nesen ir ienācis tirgū (kā, piemēram, SIA “Inbank Latvia”, kur pirmos 3 gadus koeficients bija negatīvs).

Lai veidotu ar visu kreditoru finanšu datiem lineārās regresijas modeli, tika veikta visu kreditoru datu korelācijas analīze (sk. 2.att)

	ROA	FAT	EAR	Staff	Age	PCLTL	CIR	NIM	Expenses	Debt	Asset	DER	NII	
ROA	Pearson Correlation	1	-0.101	-0.108	0.124	-.513**	-.516**	-0.088	-0.068	0.030	.342**	.271*	-0.102	.308*
	Sig. (2-tailed)		0.445	0.417	0.351	0.000	0.000	0.634	0.820	0.008	0.038	0.443	0.026	
FAT	Pearson Correlation	-0.101	1	-0.195	-0.034	-0.051	0.246	0.182	.613**	-0.081	-.358**	-.364**	0.079	-0.110
	Sig. (2-tailed)			0.139	0.800	0.699	0.065	0.168	0.000	0.543	0.005	0.005	0.554	0.437
EAR	Pearson Correlation	-0.108	-0.195	1	.511**	.583**	-0.221	0.019	-.365**	-.338**	0.111	.522**	0.022	.372**
	Sig. (2-tailed)				0.000	0.000	0.098	0.886	0.008	0.009	0.404	0.000	0.870	0.007
Staff	Pearson Correlation	0.124	-0.034	.511**	1	0.091	-0.187	0.017	-0.231	-0.129	.620**	.749**	0.015	.599**
	Sig. (2-tailed)					0.495	0.164	0.896	0.099	0.328	0.000	0.000	0.912	0.000
Age	Pearson Correlation	-.513**	-0.051	.583**	0.091	1	-0.051	-0.042	-0.065	-.295*	-0.080	0.146	0.135	0.163
	Sig. (2-tailed)						0.704	0.752	0.646	0.023	0.545	0.271	0.309	0.247
PCLTL	Pearson Correlation	-.516**	0.246	-0.221	-0.187	-0.051	1	-0.069	0.122	0.054	-.334*	-.359**	0.015	-.371**
	Sig. (2-tailed)							0.610	0.398	0.690	0.011	0.006	0.911	0.008
CIR	Pearson Correlation	-0.088	0.182	0.019	0.017	-0.042	-0.069	1	-0.154	0.092	-.415**	-.357**	0.024	-.406**
	Sig. (2-tailed)								0.276	0.489	0.001	0.005	0.855	0.003
NIM	Pearson Correlation	-0.068	.613**	-.365**	-0.231	-0.065	0.122	-0.154	1	0.221	-.274*	-.369**	0.005	0.178
	Sig. (2-tailed)									0.116	0.049	0.007	0.973	0.207
Expenses	Pearson Correlation	0.030	-0.081	-.338**	-0.129	-.295*	0.054	0.092	0.221	1	-0.126	-0.237	-0.019	-0.142
	Sig. (2-tailed)										0.342	0.070	0.888	0.314
Debt	Pearson Correlation	.342**	-.358**	0.111	.620**	-0.080	-.334*	-.415**	-.274*	-0.126	1	.889**	-0.069	.764**
	Sig. (2-tailed)												0.000	0.603
Asset	Pearson Correlation	.271*	-.364**	.522**	.749**	0.146	-.359**	-.357**	-.369**	-0.237	.889**	1	-0.066	.768**
	Sig. (2-tailed)									0.070	0.000			0.621
DER	Pearson Correlation	-0.102	0.079	0.022	0.015	0.135	0.015	0.024	0.005	-0.019	-0.069	-0.066	1	-0.099
	Sig. (2-tailed)									0.888	0.603	0.621		0.486
NII	Pearson Correlation	.308*	-0.110	.372**	.599**	0.163	-.371**	-.406**	0.178	-0.142	.764**	.768**	-0.099	1
	Sig. (2-tailed)									0.314	0.000	0.000	0.486	

\*\* Korelācija ir statistiski nozīmīga ar 99% varbūtību

\* Korelācija ir statistiski nozīmīga ar 95% varbūtību

## 2. attēls. Korelācijas matrica (Avots: autores analīzes rezultāts SPSS vidē)

Pēc korelācijas analīzes rezultātiem darba autore veido vairākus secinājumus:

- Uzņēmuma vecumam ir negatīva korelācija ar ROA, kas nozīmē to, ka jo jaunāks uzņēmums, jo tam ir lielāks ROA un otrādi.
- ROA ir negatīva korelācija ar PCLTL koeficientu, kas norāda uz to, ka jo lielāku kredītrisku uzņemas kreditors, jo tam ir lielāks ROA.
- ROA ir pozitīva korelācija ar Debt (aizņemtā kapitāla normalizēts rādītājs). Jo lielāks kreditoram ir aizņemtais kapitāls, jo tam ir lielāks ROA. Šis norāda uz to, ka uzņēmumi efektīvi izmanto aizņemtos līdzekļus, lai gūtu lielāku peļņu.
- ROA ir pozitīva korelācija ar Asset (kopējo aktīvu normalizēts rādītājs). Jo lielāks kreditoram ir kopējais aktīvu skaits, jo tam ir lielāks ROA. Šis norāda uz to, ka uzņēmumi efektīvi izmanto sev piederošos aktīvus, lai gūtu lielāku peļņu.
- ROA ir pozitīva korelācija ar NII (tīro procentu ienākumu normalizēts rādītājs). Jo lielāki kreditoram ir tīro procentu ienākumi, jo tam ir lielāks ROA.

Darba autore secina, ka starp x rādītājiem arī pastāv korelācija. Tālāk darba autore, izmantojot pakāpeniskās (stepwise) metodes daudzfaktoru lineārās regresijas, izveidoja visiem pētījumā apskatītajiem kreditoriem divus regresijas modeļus – ar brīvo locekli un bez brīvā locekļa, kur:

- Bez brīvā locekļa1:  $y = ROA$ ;  $x = NII$ .
- Bez brīvā locekļa2:  $y = ROA$ ;  $x = NII$ ; Age.
- Bez brīvā locekļa3:  $y = ROA$ ;  $x = NII$ ; Age, PCLTL.

Modeļi  $8b^1$ ,  $8b^2$  un  $8b^3$  raksturojošie rādītāji ir apkopoti 3., 4. un 5. tabulā.

**3. tabula.** Modeļa  $8b^1$ ,  $8b^2$  un  $8b^3$  statistika (Avots: autores analīzes rezultāts no SPSS vides)

Model	R	R Square <sup>b</sup>	Adjusted R Square	Std. Error of the Estimate	Durbin-Watson
$8b^1$	.715	0.511	0.501	19.64083	
$8b^2$	.834	0.695	0.682	15.66228	
$8b^3$	.891	0.793	0.780	13.02935	1.583

Koriģētais determinācijas koeficients  $8b^1$  modelī ir 0.501, kas norāda uz to, ka 50.1 % ROA variācijas ir izskaidrojama ar NII normalizēto rādītāju.

Durbin Watson rādītāji ir šādi:  $n = 8$ ;  $p = 1$ .

$dL = 0.497$ ;  $dU = 1.003$

$DW = 1.583 > 1.003$  - Nav pozitīvas autokorelācijas

$4 - DW = 4 - 1.583 = 2.417 > 1.003$  - Nav negatīvas autokorelācijas

Durbin – Watson koeficients  $8b^1$  modelī ir 1.583, kas ir lielāks par apakšējo kritisko vērtību un lielāks par augšējo kritisko vērtību, tātad autokorelācija atlikumos nepastāv.

Koriģētais determinācijas koeficients  $8b^2$  modelī ir 0.682, kas norāda uz to, ka 68.2% ROA variācijas ir izskaidrojamas ar NII normalizēto rādītāju un uzņēmuma vecumu.

Durbin Watson rādītāji ir šādi:  $n = 8$ ;  $p = 2$ .

$dL = 0.345$ ;  $dU = 1.489$

$DW = 1.583 > 1.489$  - Nav pozitīvas autokorelācijas

$4 - DW = 4 - 1.583 = 2.417 > 1.489$  - Nav negatīvas autokorelācijas

Durbin – Watson koeficients  $8b^2$  modelī ir 1.583, kas ir lielāks par apakšējo kritisko vērtību un lielāks par augšējo kritisko vērtību, tātad autokorelācija atlikumos nepastāv.

Koriģētais determinācijas koeficients  $8b^3$  modelī ir 0.780, kas norāda uz to, ka 78 % ROA variācijas ir izskaidrojamas ar PCLTL, NII koeficientu un uzņēmuma vecumu.

Durbin Watson rādītāji ir šādi:  $n = 8$ ;  $p = 3$ .

$dL = 0.229$ ;  $dU = 2.102$

$DW = 1.583 < 2.102$  - Ir pozitīva autokorelācija

$4 - DW = 4 - 1.583 = 2.417 > 2.102$  - Nav negatīvas autokorelācijas

Durbin – Watson koeficients  $8b^3$  modelī ir 1.583, kas ir zemāks par augšējo kritisko vērtību, tātad ir pozitīva autokorelācija atlikumos.

**4. tabula.** Modeļa  $8b^1$ ,  $8b^2$  un  $8b^3$  ANOVA (dispersijas analīzes rezultāti) (Avots: autores analīzes rezultāts no SPSS vides)

Model		Sum of Squares	df	Mean Square	F	Sig.
8b <sup>1</sup>	Regression	19714.862	1	19714.862	51.106	<.001
	Residual	18902.342	49	385.762		
	Total	38617.204	50			
8b <sup>2</sup>	Regression	26842.463	2	13421.232	54.712	<.001
	Residual	11774.741	48	245.307		
	Total	38617.204	50			
8b <sup>3</sup>	Regression	30638.300	3	10212.767	60.159	<.001
	Residual	7978.905	47	169.764		
	Total	38617.204	50			

Modeļa  $8b^1$  testa vērtība ir 0.001. Modulis nav statistiski nozīmīgs, jo  $\text{Sig.} = 0.001 < 0.005$ , ar varbūtību 95 %.

Modeļa  $8b^2$  testa vērtība ir 0.001. Modulis ir statistiski nozīmīgs, jo  $\text{Sig.} = 0.001 < 0.005$ , ar varbūtību 95 %.

Modeļa  $8b^3$  testa vērtība ir 0.001. Modulis ir statistiski nozīmīgs, jo  $\text{Sig.} = 0.001 < 0.005$ , ar varbūtību 95 %.

**5.tabula.** Modeļa  $8b^1$ ,  $8b^2$  un  $8b^3$  koeficientu statistika (Avots: autores analīzes rezultāts no SPSS vides)

Model		Unstandardized Coefficients		Standardized Coefficients	t	Sig.	Collinearity Statistics	
		B	Std. Error	Beta			Tolerance	VIF
8b <sup>1</sup>	NII	1.303	0.182	0.0715	7.149	0.000	1.000	1.000
8b <sup>2</sup>	NII	2.982	0.344	1.636	8.674	0.000	0.179	5.598
	Age	-2.386	0.443	-1.016	-5.390	0.000	0.179	5.598
8b <sup>3</sup>	NII	3.388	0.299	1.858	11.346	0.000	0.164	6.102
	Age	-2.322	0.368	-0.0989	-6.302	0.000	0.178	5.605
	PCLTL	-0.655	0.139	-0.0400	-4.729	0.000	0.616	1.624

VIF rādītājs  $8b^1$  modelī =  $1 < 10$ , līdz ar to daudzkolinearitātes problēma nepastāv.

Koeficientu novērtējums ir pozitīvs, norādot, ka NII pieaugums ir saistīts ar ROA samazinājumu. NII ir statistiski nozīmīgi, jo:  $\text{Sig.} = 0.000 < 0.05$ .

Pārbaudot visas regresijas analīzes koeficientus  $8b^1$  modelī, var tikt izveidots modelis:

$$\text{ROA} = 0.0715 * \text{NII}$$

VIF rādītājs  $8b^2$  modelī =  $11.196 > 10$ , līdz ar to pastāv daudzkolinearitātes problēma.

Koeficientu novērtējums ir pozitīvs, norādot, ka uzņēmuma vecuma pieaugums un NII koeficients ir saistīts ar ROA izmaiņām. NII un Age ir statistiski nozīmīgi, jo:

$$\text{Sig.}_{(\text{Age})} = 0,000 < 0,05;$$

$$\text{Sig.}_{(\text{PCLTL})} = 0,000 < 0,05.$$

Pārbaudot visus regresijas analīzes koeficientus, darba autore nolemj neveidot modeli, jo  $\text{VIF} = 11.196$ , kas norāda uz to, ka pastāv daudzkolinearitātes problēma.

VIF rādītājs  $8b^3$  modelī =  $13.331 > 10$ , līdz ar to pastāv daudzkolinearitātes problēma.

Koeficientu novērtējums ir pozitīvs, uzņēmuma vecuma pieaugums, NII un PCLTL koeficienta samazināšanās ir saistīts ar ROA izmaiņām. NII, Age un PCLTL ir statistiski nozīmīgi, jo:

$$\text{Sig.}_{(\text{NII})} = 0,00 < 0,05;$$

$$\text{Sig.}_{(\text{Age})} = 0,000 < 0,05;$$

$$\text{Sig.}_{(\text{PCLTL})} = 0,000 < 0,05.$$

Pārbaudot visus regresijas analīzes koeficientus, darba autore nolemj neveidot modeli, jo  $\text{VIF} = 13.331$ , kas norāda uz to, ka pastāv daudzkolinearitātes problēma.

Veicot lineārās regresijas analīzi visiem uzņēmumiem kopā, tika izveidoti viens modelis:  $\text{ROA} = 0.0715 * \text{NII}$ .

No vienādojuma var secināt, ka tīrie procentu ienākumi ir tas mainīgais, kas ietekmē uzņēmuma pelnītspēju. Vienādojumā ir attēlots, ka katrai 1 vienības pieaugumam tīro procentu ienākumu pozīcijā, kreditoru aktīvu rentabilitāte palielinās 0.0715 vienību reizes.

## Secinājumi

Zinātniskā darba izstrādes laikā darba autore izstrādāja vairākus secinājumus:

- Darba mērķis “Identificēt Latvijas nebanku kreditēšanas sektora uzņēmumu pelnītspēju ietekmējošus faktorus” tika sasniegts.
- Balstoties uz modeli, kas izveidots ar lineārās regresijas analīzes palīdzību, kura aprēķinos tika izmantoti visu uzņēmumu rādītāji, tika atklāts, ka kopējais rādītājs, kas varētu tikt piemērots katram uzņēmumam kā pelnītspēju veidojošs ir tīro procentu ienākumi.
- Analizējot Latvijas nebanku kreditēšanas sektoru, darba autore secina, ka tā turpina augt un pieņemt apgrozījumus. 2023. gada izsniegto kredītu apjoms ir būtiski pieaudzis neskatoties uz to, ka kreditoru skaits ir samazinājies. Nozares attīstība nāk par labu ne tikai pašiem uzņēmumiem, jo tiem ir iespēja attīstīties, bet arī patērētājiem, jo tiem ir iespējamas



salīdzināšanas un izvēles iespējas uz sev izdevīgākajiem un piemērotākajiem kreditēšanas nosacījumiem.

### Izmantotās literatūras un informācijas avotu saraksts

- Azzabi A., & Lahrinchi Y. (2023). Bank performance determinants: state of the art and future research avenues. *New Challenges in Accounting and Finance*, 26(9).
- Cheng, J., Sun, J., Yao, K., Xu, M., & Cao, Y. (2022). A variable selection method based on mutual information and variance inflation factor. *Spectrochimica Acta Part A: Molecular and Biomolecular Spectroscopy*, 268. <https://doi.org/10.1016/j.saa.2021.120652>
- Dembel, B. (2020). Factors affecting the performance of commercial banks (a case study on commercial banks in Ethiopia): CAMEL ratings. *Research Journal of Finance and Accounting*, 11(5).
- Fibriyanti, Y., V., & Nurcholidah, L. (2020). Analysis of factors that affect the financial performance of banks. *Advances in Engineering Research*, 205.
- Fredriksson, I. (2020). *How to create high profitability. The four foundations of profitability*. Publish Drive Incorporated
- Hasna, D. P., Ariyani, D., S., Ula, L., F., Putri, R., S., & Prayitno, Y., H. (2020). The effect of third-party funds and liquidity (LDR) on banking profitability (ROA) (case study of BUMN banks listed on the Indonesia stock exchange from 2012 to 2019). *Palarch's Journal of Archaeology of Egypt/Egyptology*, 17(4), 2914-2927.
- Jansons, V., & Kozlovskis, K. (2012). *Ekonomiskā prognozēšana SPSS vidē*. RTU izdevniecība.
- Kawshala, H., & Panditharathna, K. (2017). The factors effecting on bank profitability. *International Journal of Scientific and Research Publications*, 7(2).
- Kredītiestāžu likums (spēkā esošā redakcija, 24.10.1995). *Latvijas Vēstnesis*, 163, 24.10.1995.; *Latvijas Republikas Saeimas un Ministru Kabineta Ziņotājs*, 23, 07.12.1995. <https://likumi.lv/ta/id/37426-kreditiestazu-likums>
- Makroekonomika.lv (2024). *Kredītiestāžu pelnītspēja 2023. gadā – kā veidojies straujais pieaugums?* [https://www.makroekonomika.lv/raksti/kreditiestazu\\_pelnitspeja-2023-gada-ka-veidojies-straujais-pieaugums](https://www.makroekonomika.lv/raksti/kreditiestazu_pelnitspeja-2023-gada-ka-veidojies-straujais-pieaugums)
- CRIF Digital (2022). Lending in banking: Benefits and best practices. <https://www.crif.digital/blog/lending-in-banking-benefits-and-best-practices/>
- Latvijas Republikas Saeimas un Ministru Kabineta Ziņotājs (2008). Noziedzīgi iegūtu līdzekļu legalizācijas un terorisma un proliferācijas finansēšanas novēršanas likums (spēkā esošā redakcija, 13.08.2008). *Latvijas Vēstnesis*, 116, 30.07.2008. <https://likumi.lv/ta/id/178987-noziedzīgi-iegutu-lidzeklu-legalizācijas-un-terorismafinansēšanas-noversanas-likums>
- Ngweshemi, L., E. & Isiksal, A., Z. (2021). Analysis of the factors affecting bank profitability: Evidence of Tanzania commercial banks. *Sustainable Economic Development: Pattern and Perspective*, 39(8).
- Paupa, V., & Šneidere, R. (2008). *Uzdevumu krājums finanšu analīzē*. Baltimoras konsultāciju centrs.
- PTAC (2023). Pārskats par patērētāju (nebanku) kreditēšanas tirgus darbību 2023.gada I.pusgadā. <https://www.ptac.gov.lv/lv/media/4008/download?attachment>





- Saksonova, I. (2006). *Banku darbība*. Latvijas Komerčbanku asociācijas Konsultāciju un mācību centrs.
- Saksonova, S. (2012) *Finanšu informācijas un pārskatu praktiskā izmantošana uzņēmumu finanšu lēmumu pieņemšanā*. Info tilts.
- Sauka, A. (2023). *Nebanku kreditēšanas nozare Latvijā sāk līdzināties banku nozarei*. <https://fla.lv/arnis-sauka-nebanku-kreditesanas-nozare-latvija-sak-lidzinaties-banku-nozare/>
- Statistics Solutions (n.d.). Significance <https://www.statisticssolutions.com/free-resources/directory-of-statisticalanalyses/significance/>
- Tmava, Q., Berisha, F., & Mehmeti, M. (2019). Comparative analysis of banking system profitability in Western Balkan countries. *Journal of Economics and Management Sciences*, 2(2), 33-44.
- Wagdi, O., & Salman, E. (2022). Determinants of a bank's performance in emerging markets: Evidence from Egypt. *Academy of Accounting and Financial Studies Journal*, 26(4).



## Līga Prancāne. AUTOMATIZĀCIJAS PROCESU IETEKME UZ GRĀMATVEDĪBAS PROCESU KVALITĀTES UZLABOŠANU LATVIJAS UZŅĒMUMOS

*Ekonomikas un kultūras augstskola  
Maģistra studiju programma "Biznesa vadība"  
E-pasts:prancane81@gmail.com  
Zinātniskais vadītājs: Dr.oec., profesore Jeļena Titko*

### Anotācija

**Pētījuma aktualitāte:** Datorizēto finanšu sistēmu izsekošanas iespējas ļauj grāmatvežiem pārraudzīt ieņēmumu gūšanas un tēriņu tendences, tādējādi atvieglojot pārdomātu biznesa lēmumu pieņemšanu (ACCA, 2020). Pētījumi atklājuši, ka grāmatvedības procesu automatizācija ir palielinājusi grāmatvežu produktivitāti un darba kvalitāti. Automatizācija ļauj ievadīt un analizēt dažādas datu kopas vienā datu bāzē, lai efektīvi veiktu analīzes. (Rkein, 2019). Balstoties uz ACCA aptaujas rezultātiem 85% respondentu uzsver, ka procesu automatizācija pārspēj nefinansiālos ieguvumus piemēram precizitāti un laika ietaupījumu (ACCA, 2018a; Deloitte, 2018).

**Pētījuma mērķis:** Novērtēt automatizācijas procesu ietekmi uz grāmatvedības procesu kvalitātes uzlabošanu Latvijas uzņēmumos.

**Pētījuma metodes** tika veikta literatūras un dokumentu analīze, lai identificētu ieguvumus un izaicinājumus no grāmatvedības procesu automatizācijas. Grāmatvedības un finanšu jomas ekspertu intervijas ar mērķi lai iegūtu profesionālu skatījumu par ieguvumiem, trūkumiem. Latvijas grāmatvežu aptauja lai identificētu grāmatvedības procesus, kas ir potenciāli automatizējami, to lielākos ieguvumus un izaicinājumus, kā arī saprastu grāmatvežu nostāju un zināšanas saistībā ar automatizētu procesu ieviešanu. Lai veidotu izpratni par grāmatvedības procesu automatizāciju koncepcijas līmenī tika veikta bibliometriskā analīze. Iegūto rezultātu apstrādei izmantotas tādas metodes, kā grafiskā analīze, biežuma analīze un intervijas rezultātu analīze.

**Sasniegtie rezultāti:** Pētījuma rezultātā tika novērtēta automatizācijas procesu ietekme uz grāmatvedības procesu kvalitātes uzlabošanu Latvijas uzņēmumos, kā arī tik atrastas atbildes uz pētījuma jautājumiem par automatizācijas ieguvumiem un izaicinājumiem un par automatizācijas ietekme uz procesa kvalitāti.

*Atslēgas vārdi: digitalizācija; produktivitāte; analīze; procesu automatizācija.*

### Ievads

Nesenie pētījumi atklāja, ka grāmatvedības automatizācija palielina uzņēmuma grāmatveža darba produktivitāti un kvalitāti. Automatizācija ļauj ievadīt un analizēt dažādas datu kopas vienā datu bāzē un produktivitāti. (ACCA, 2018b, 2020). Vēl viena būtiska automatizācijas priekšrocība ir tā, ka tā ietaupa laiku, salīdzinot ar manuālu darbību veikšanu. Saskaņā ar neseno pētījumu grāmatvedības procesu automatizācija var palīdzēt samazināt pieļauto kļūdu daudzumu un biežumu. Turklāt automatizēti procesi nerada kļūdainus aprēķinus, jo viss notiek kontrolētā vidē. Tomēr daļa uzņēmumu vadītāju ir vilcinājušies pieņemt procesu automatizāciju augsto izmaksu dēļ (Osborne, 2017). Balstoties uz ACCA aptaujas rezultātiem 85% respondentu uzsver, ka procesu automatizācija pārspēj nefinansiālos

ieguvumus piemērām precizitāti un laika ietaupījumu (ACCA, 2018a; Deloitte, 2018). Ir prognozēts, ka paredzamā automatizācijas iespējamā ekonomiskā ietekme līdz 2025. gadam sasniegs 6.7 triljonus dolāru (Doguc, 2020).

Pētījuma mērķis bija novērtēt automatizācijas procesu ietekmi uz grāmatvedības procesu kvalitātes uzlabošanu Latvijas uzņēmumos. Pētījuma rezultāti raksturo automatizācijas līmeni Latvijas uzņēmumos un dod ieskatu tajā, kā grāmatveži skatās uz automatizācijas procesu ietekmi uz grāmatvedības procesu kvalitātes uzlabošanu, kādus izaicinājumus tajā saskata un vai uzskata par pamatotu ekonomisko ieguvumu, veicot šādas izmaiņas.

### Analītiskais apskats

Grāmatvedības procesu iedala deviņās darbību sadaļās, kas tiek atkārtotas ikmēnesi pārskata periodā. Process sākas ar grāmatvedības ierakstu veikšanu katram darījumam un tad seko ikmēneša slēgšanas process. Šāds process nodrošina finanšu pārskatu precizitāti un atbilstību (sk. 1. att.).



**1.att.** Grāmatvedības cikli (Avots: Richardson, 2011,13)

Pēdējo gadu laikā grāmatvedības jomu Eiropā iezīmē vairākas ievērojamas tendences, kas maina tās ainavu. Vienas no visizplatītākajām tendencēm Eiropas kā arī Latvijas grāmatvedībā ir:

- Digitālo tehnoloģiju un automatizācijas paātrināta ieviešana;
- Ilgtspējības ziņošana un vides, sociālo un pārvaldības;
- Mākslīgais intelekts;
- Darba vietas elastība un attālinātās darba iespējas;
- Kvalificēta darbinieku trūkums (Leinonen Group, 2023).

Digitālo tehnoloģiju un automatizācijas paātrināta ieviešana. Līdz ar mākslīgā intelekta parādīšanos grāmatvedības procesi kļūst efektīvāki un precīzāki. Šī tendence ir acīmredzama pieaugošajā

grāmatvedības programmatūras izmantošanā, piemēram, uzņēmuma resursu plānošanas sistēmās (Leinonen Group, 2023).

Digitalizācija un automatizācija pārveido ikdienas uzdevumus, tostarp datu ievadi, saskaņošanu un darījumu apstrādi. Tas ļauj grāmatvežiem novirzīt uzmanību no manuālas datu ievades uz darbībām ar pievienoto vērtību, piemēram, datu analīzi, interpretāciju un stratēģisko finanšu plānošanu. Lai gan šī tendence uzlabo efektivitāti un samazina kļūdu skaitu, tā arī liek grāmatvežiem apgūt jaunas prasmes datu analīzē un tehnoloģijās, lai saglabātu konkurētspēju šajā nozarē (Romashko et al., 2023).

Tuvākajos gados automatizācija turpinās mainīt to, kā tiek veiktas "tradicionālās" grāmatvedības procedūras. Datu ievades, saskaņošanas, finanšu pārskatu un ar atbilstību saistītās darbības racionalizēšana būs ļoti svarīga, lai grāmatveži un viņu uzņēmumi gūtu panākumus. Tā kā tehnoloģija uzņemas lielāku daļu no ikdienas uzdevumiem, finanšu ekspertiem tiks dota iespēja pagriezties un sniegt lielāku ieguldījumu uzņēmuma mērķu sasniegšanā. Un, tā kā finanšu profesionāļa loma šādā veidā attīstās, uz datiem balstīta lēmumu pieņemšana būs vēl svarīgāka.

Tika secināts ka grāmatveža profesijas nākotni ietekmē šādas galvenās tendences:

- Uzņēmuma attīstības stratēģijā galveno vietu ieņems automatizācija;
- Vislielākais uzsvars tiks likts uz profesionālo izaugsmi, kas balstīta uz jaunākajām tehnoloģijām;
- Darba vietā ir jānodrošina lielāka elastība;
- Grāmatvedības uzņēmumiem būs jāmeklē darbinieki darbībām, kas iepriekš nebija raksturīgas (WEF, 2023).

Tiek lēsts, ka biznesa grāmatvedības programmatūras tirgus apjoms pieaugs par 7.96% no 2023. līdz 2028. gadam. Tiek prognozēts, ka tirgus apjoms palielināsies par 2.78 miljardiem eiro. Apkopojot iepriekš minēto, saistībā ar grāmatvedības tendencēm ir skaidri sagaidāmas lielas izmaiņas grāmatvedības industrijā saistībā ar automatizētiem procesiem un grūtībām ar ko var saskarsies jau esošie grāmatveži un topošie grāmatveži ienākot mūsdienu darba tirgū. Prasmes, kas būs nepieciešamas augs pieaugošajai tendencei automatizēt procesus, lai palielinātu darba efektivitāti. Grāmatveža darba iemaņas prasīs vairāk zināšanu, lai varētu operēt mūsdienu darba vidē, kas būs gan kā izaicinājums, gan iespēja sevi pilnveidot. Tiek sagaidītas arī pozitīvas izmaiņas, kas tiešā veidā ir saistītas ar manuālu darbi veikšanu samazināšanu, kas rezultēsies lielākā produktivitāte un izmaksu samazināšanā.

### Pētījuma metodoloģija

Lai sasniegtu darbā izvirzīto mērķi un noskaidrotu pētījuma jautājumus autore veica sekojošus pētījuma posmus (sk. 1. tabulu).

**1.tabula.** Pētījuma posmi un rezultāti (Avots: autores apkopojums)

Nr.	Pētījuma posms	Rezultāts
1.	Literatūra un dokumentu apskats	<ul style="list-style-type: none"> <li>- Tika veikts pētījumu analītiskais apkopojums;</li> <li>- Darbā izmantoti un analizēti 89 literatūras un informācijas avoti;</li> <li>- Tika izcelti ieguvumi un šķēršļi, kas tālāk tiek izmantoti jautājumu izstrādē.</li> </ul>

		- Tika veikta bibliometriskā datu analīze kurā autore apskatīja literatūru saistībā ar automatizētiem procesiem grāmatvedībā.
2.	Anketas izstrāde grāmatvežiem	- Izveidota aptaujas anketa Latvijas grāmatvežiem; - Anketa ieviesta Google Forms aptaujas veidlapā.
1.	Jautājumu izstrāde ekspertu intervijām	- Balstoties uz analītisko apskatu un literatūras analīzi, izveidota aptaujas anketa ekspertu aptaujai
4.	Datu vākšana	- Grāmatvežu aptaujā iegūtas 102 respondentu atbildes; - Veiktas 5 ekspertu intervijas un aptaujas.
5.	Datu apstrāde	- Sagatavots datu fails datu analīzei; - Sagatavots fails ekspertu aptaujas datiem; - Veikta grafiskā analīze kurā sagatavota datu vizualizācija un detalizēts apraksts; - Veikta biežuma analīze; - Analizēti ekspertu interviju un aptauju rezultāti.
6.	Galvenie posmi grāmatvedības procesu automatizācijas ieviešanai	- Izstrādātas grāmatvežu procesu automatizācijas vadlīnijas Latvijas grāmatvežiem un uzņēmuma vadītājiem ar ieteikumiem, norādēm uz ieguvumiem un trūkumiem.

Literatūras un dokumentu apskata mērķis bija detalizēti izpētīt pieejamo literatūra saistībā ar grāmatvedības procesu automatizāciju un sniegt ieskatu, cik detalizēti tiek pētīts aktuālais jautājums, kā arī izvērtēt ieguvumus un izaicinājumus, ar ko saskaras uzņēmumi, veicot šīs izmaiņas grāmatvedības procesos. Tika veikta bibliometriskā datu analīze, kurā autore apskatīja literatūru saistībā ar automatizētiem procesiem grāmatvedībā. Grāmatvežu aptaujas un ekspertu interviju mērķis bija iegūt nepieciešamo informāciju pētījuma mērķa ietvaros. Google Forms tika izstrādāti grāmatvežu aptaujas jautājumi, kas ļāva operatīvi izstrādāt un izsūtīt izstrādāto aptauju. Grāmatvežu aptaujā iegūtas 102 respondentu atbildes. Ekspertu intervijās piedalījās 5 finanšu eksperti. Grāmatvežu iegūtie dati tiek analizēti un vizualizēti, izmantojot Google Excel, lai operatīvāk prezentētu iegūtos datus. Savukārt ekspertu intervijas tika analizētas, meklējot kopsaucējus katrā no uzdotajiem jautājumiem. Darba autore veica grafisko analīzi kurā sagatavota datu vizualizācija un detalizēts apraksts, veikta biežuma analīze un analizēti ekspertu interviju un aptauju rezultāti. Balstoties uz datiem un veikto analīzi, pētījuma beidzamajā solī darba autore veica vadlīniju izstrādi ar rekomendācijām un ieteikumiem Latvijas grāmatvežiem.

Lai izstrādātu aptaujas anketu, kas atbilst izstrādātajam pētījuma mērķim, darba autore sākumā veica interneta resursu izpēti, lai identificētu grāmatvedības procesus, kas ir potenciāli automatizējami, to lielākos ieguvumus un izaicinājumus, kā arī saprastu grāmatvežu nostāju un zināšanas saistībā ar automatizētu procesu ieviešanu. Iegūtā informācija tika izmantota kā pamats aptaujas instrumenta (anketas) izstrādei un jautājumu sagatavošanai. Kopā darba autore izstrādāja 15 jautājumus, kas palīdzēs labāk izprast situāciju Latvijā (sk. 2.tabulu).

**2. tabula.** Aptaujas anketā iekļautie jautājumi un pamatojums to izmantošanā (Avots: autores apkopojums)

Jautājums	Pamatojums
1. Jūsu vecums - 18-25	Vecums ir būtisks demogrāfisks rādītājs, kas var dot ieskatu par to, kāda ir mērķa auditorija, un palīdzēt pielāgot ieteikumus konkrētajai vecuma grupai. Aptaujas anketā autore nav iekļāvusi vecuma grupu no 1-17 gadiem, jo tas neatbilst Latvijas

<ul style="list-style-type: none"> <li>- 26-35</li> <li>- 36-45</li> <li>- 45-65</li> <li>- 65 +</li> </ul>	<p>darbaspēka vecuma grupai. Vecuma grupa 65 + ir pielīdzināma pensijas vecumam. Ietverot atbilstošus vecuma spektrus aptaujā, autore var nodrošināt plašāku un pārdomātāku datu kopumu, analizējot dažādus sabiedrības viedokļus.</p>
<p>2. Lūdzu, norādiet savu dzimumu.</p>	<p>Šis jautājums ir svarīgs, jo var parādīt dzimuma atšķirības attiecībā uz viedokļiem, uzskatiem un ieradumiem.</p> <p>Dzimuma faktors var ietekmēt profesijas izvēli. Labās prakses palīdz nodrošināt taisnīgu iekļaušanu darba vidē, tādēļ autore aptaujā kā variantu iekļāva arī netradicionālo dzimumu. Dzimuma līdztiesība balstīta darba vidē, un darba devēji ir tie, kuri var šo situāciju ietekmēt pozitīvi. (KANTAR, 2019)</p>
<p>3. Kāda Jums ir pēdējā pabeigtā izglītība?</p>	<p>Izglītības līmenis ir būtisks sociālais un ekonomiskais rādītājs, kas var ietekmēt respondentu uzskatus, spēju un vēlmes. Šis jautājums var palīdzēt saprast respondentu izglītības līmeni un identificēt attiecības starp izglītību un citiem faktoriem, piemēram, spēju un velmi ieviest automatizētus procesus. Izglītība ir galvenais sociālā rādītāja mainīgais, uz kuru attiecas visi respondenti, ko izmanto daudzās statistikas analīzēs (Schneider, 2021).</p>
<p>4. Cik gadus jau strādājat par grāmatvedi?</p>	<p>Šis jautājums sniedz informāciju par respondentu profesionālo pieredzi un darba stāžu. Tas ir noderīgi, lai saprastu respondentu kompetenci un zināšanas par grāmatvedību. Tas var palīdzēt novērtēt respondentu viedokļus saistībā ar pētījuma mērķi (Stoop &amp; Harrison, 2012).</p>
<p>5. Kuram no šiem statusiem atbilst uzņēmums, kurā Jūs strādājat?</p> <ul style="list-style-type: none"> <li>- Mikro</li> <li>- Mazais</li> <li>- Vidējais</li> <li>- Lielais</li> </ul>	<p>Šis jautājums tika iekļauts, lai saprastu respondentu darba vidi un darba organizācijas īpašības. Tas var būt noderīgs, lai novērtētu uzņēmumu struktūru, kultūru un darba apstākļus saistībā ar automatizētiem procesiem. Uzņēmuma lieluma dalījums tika ņemts vērā, jo automatizācijas procesa ieviešanai var būt vairākas priekšrocības, kas var būt izdevīgas dažādiem faktoriem neatkarīgi no uzņēmuma lieluma. Uzņēmuma lieluma dalījums atbilst Eiropas Komisijas (EK) regulas Nr.651/2014 1. pielikumā noteiktajai definīcijai (LIAA, 2020).</p>
<p>6. Vai jūs esat ārpakalpojuma vai uzņēmuma grāmatvedis? Ja esat ārpakalpojuma, tad turpinājumā lūdzu sniegt atbildes par uzņēmumu kurā jūs strādājat.</p>	<p>Darba autore iekļāva šo jautājumu lai ārpakalpojuma grāmatvedis kas sniedz savus pakalpojumus vairākiem klientiem spētu saprast, ka turpmākie aptaujas jautājumi jāatbild par uzņēmumu kurā strādā.</p>
<p>7. Vai Jūs ziniet, kas ir procesa automatizācija?</p>	<p>Darba autore iekļāva šo jautājumu, lai uzzinātu kādas ir respondentu zināšanas par robotiskiem automatizācijas procesiem, kas ļauj dziļāk saprast respondentu profilu un operatīvāk veikt datu analīzi saistībā ar pētījuma mērķi. Jautājums palīdz izprast un identificēt šī brīža situāciju kopumā.</p>
<p>8. Ja jūsu uzņēmumā tika ieviesti automatizēti procesi, tad kādus labumus tie dod?</p>	<p>Darba autore iekļāva šo jautājumu, jo ir nepieciešams saprast, kādi procesi potenciāli varētu tikt automatizēti un cik ļoti uzņēmumā grāmatveži saskata, kuros procesos ir automatizācijas potenciāls. Potenciālie procesi, kuri varētu tikt automatizēti, tika sagatavoti balsoties uz O.Doguc veiktā pētījumu, kur tika izklāstīti procesi ar vislielāko potenciālu. (Doguc, 2020, 18-20)</p>
<p>9. Pēc Jūsu domām, kāds ir automatizācijas līmenis Jūsu uzņēmumā grāmatvedības procesiem?</p>	<p>Jautājums aptaujā izmantots ar mērķi palīdzēt rast atbildes uz maģistra darba pētījuma jautājumu: Kāds ir grāmatvedības procesu automatizējas līmenis šobrīd Latvijā? Tas ļaus darba autore dziļāk izprast esošo situāciju starp Latvijas grāmatvežiem un automatizācijas līmeni.</p>
<p>10. Cik augstā līmenī jūsu uzņēmumā jau notiek grāmatvedības procesu automatizācija?</p>	<p>Jautājums aptaujā izmantots ar mērķi palīdzēt rast atbildes uz maģistra darba pētījuma jautājumu: "Kāds ir grāmatvedības procesu automatizējas līmenis šobrīd Latvijā?" Atbilžu varianti tika balstīti uz veikto pētījumu, kur tika uzskaitīti procesi ar vislielāko potenciālu automatizācijai. (Hazar &amp; Toplu 2023, 2)</p>

<p>11. Kā jūs uztverat automatizācijas ietekmi uz darba lomām un pienākumiem grāmatveža profesijā?</p>	<p>Darba autore iekļāva šo jautājumu, lai izprastu, kā grāmatveži uztver automatizācijas ietekmi uz savām darba lomām un pienākumiem ikdienā. Tas palīdzēs izprast, vai grāmatveži jūtas apdraudēti vai iesaistīti šajā procesā, un kādas izmaiņas viņi gaida vai vēlētos redzēt savā profesionālajā vidē, kā arī vai viņi ir gatavi pielāgoties un apgūt jaunas tehnoloģijas un vai tas varētu radīt risku viņu darbam un nodarbinātībai. Tas ir svarīgi, lai plānotu nākotnes izglītības programmas un pielāgotu profesionālās attīstības iespējas (Adrianto, 2022).</p>
<p>12. Kādas izmaiņas var sagaidīt grāmatvedības profesijā, paaugstinoties automatizācija?</p>	<p>Jautājums aptaujā izmantots ar mērķi palīdzēt rast atbildes uz maģistra darba pētījuma jautājumu: "Kādas ir galvenās priekšrocības un izaicinājumi, ar ko sastopas, ieviešot automatizācijas risinājumus grāmatvedības procesos?". Pieaugošajai lomai automatizētajos procesos tradicionālo grāmatveža lomu nākotnē lielā mērā vai pat pilnībā nomainīs automatizēti procesi. (Langmann &amp; Kokina, 2021, 7-9). Tādēļ ir svarīgi saprast potenciālās izmaiņas un grāmatvežu nostāju.</p>
<p>13. Kādi, Jūsaprāt, ir galvenie faktori, kas nosaka veiksmīgu automatizētu procesu ieviešanu grāmatvedības praksē?</p>	<p>Darba autore iekļāva šo jautājumu, lai atklātu respondentu prioritātes un uzskatus attiecībā uz automatizācijas procesu ieviešanu grāmatvedības jomā. Tas var ietvert to, kā respondentu viedokļi par tehnoloģiskajiem risinājumiem, cilvēkresursiem vai izmaiņu vadību var ietekmēt veiksmīgu ieviešanu (Adrianto, 2022).</p>
<p>14. Kāda līmeņa apmācība vai kvalifikācijas paaugstināšana, jūsaprāt, ir nepieciešama grāmatvežiem, lai efektīvi izmantotu automatizācijas procesu tehnoloģiju?</p>	<p>Šis jautājums ļaus rast ieskatu apmācības vai kvalifikācijas līmenī, kas nepieciešams, lai veiksmīgi pārvaldītu un izmantotu automatizācijas procesu tehnoloģijas. Tas var atklāt, vai grāmatveži pašlaik ir gatavi pārņemt jaunas prasmes, vai arī ir nepieciešama papildu apmācība, kas ļaus efektīvi veikt turpmāko darbu vidē, kur liela daļa no procesiem ir automatizēti (Ayinla, 2024).</p>
<p>15. Cik lielā mērā var uzlaboties grāmatvedības procesu kvalitāte, ieviešot automatizētus procesus?</p>	<p>Jautājums aptaujā izmantots ar mērķi palīdzēt rast atbildes uz maģistra darba pētījuma jautājumu: "Kāda ir automatizācijas procesu ietekme uz grāmatvedības datu precizitāti un ticamību Latvijā?". Savukārt darba autore balstīja atbilžu variantus uz nesen veikto pētījumu, kurā tika uzskaitīti procesi, kuros iegūs vislielākos ieguvumus (Hazar &amp; Toplu, 2023, 3).</p>

Apkopojot minēto, darba autore var secināt, ka pētījuma instruments ir veidots, balstoties uz diviem galvenajiem principiem, lai ar tā palīdzību tiktu izpildīti darba uzdevumi un rastas atbildes uz pētījuma jautājumiem, kā arī, lai tiktu ievērota aptaujas anketas izveides korektā prakse. Aptaujas anketa ir veidota, lai neaizņemtu vairāk kā 10 minūtes respondentu laika un pārlietu to negarlaikotu, kā arī anketā iekļauti paskaidrojošie teksti, lai izvairītos no skalu vai jautājumu tekstu interpretācijas.

### Pētījuma rezultāti

Apkopojot pētījuma rezultātus tika definēti galvenie posmi grāmatvedības procesu automatizācijas ieviešanai Sākot ar procesu auditu un beidzot darbinieku apmācībām. Darba mērķis bija novērtēt automatizācijas procesu ietekmi uz grāmatvedības procesu kvalitātes uzlabošanu Latvijas uzņēmumos ir sasniegts, kā arī tik atrastas atbildes uz 2 pētījuma jautājumiem Par automatizācijas ieguvumiem un izaicinājumiem un par automatizācijas ietekme uz procesa kvalitāti. Divi galvenie faktori sekmīgas automatizācijas ieviešanai ir tehnoloģiskā infrastruktūra kā arī atbalsts personālam.

	1-Nevar uzlaboties	2-Daļēji nevar uzlaboties	3-Neitrāli	4-Daļēji	5-Ievērojami uzlabosies
Statistikas datu apkopošana un iesniegšana CSP	1.0%	3.9%	12.7%	36.3%	46.1%
Datu apmaiņa ar banku sistēmām	1.0%	1.0%	5.9%	20.6%	71.6%
Noliktavas preču kustības analīze	0.0%	2.9%	8.8%	31.4%	56.9%
Inventarizācijas datu apkopošana un salīdzināšana	2.0%	0.0%	10.8%	24.5%	62.7%
Izmaksu sadale pa budžetiem	1.0%	1.0%	6.9%	44.1%	47.1%
Kases datu apmaiņa – e kasi	0.0%	0.0%	4.9%	45.1%	50.0%
Debitoru, Kreditoru pārvaldība	1.0%	1.0%	4.9%	31.4%	61.8%
Klientu rēķinu izrakstīšana un nosūtīšana tīmeklī	0.0%	0.0%	0.0%	30.4%	69.6%
Atskaišu izveidošana un importēšana VID sistēmā	0.0%	2.9%	4.9%	16.7%	75.5%
Starp uzņēmumu salīdzināšanās	2.0%	2.9%	7.8%	24.5%	62.7%
Algu aprēķins un izmaksas	0.0%	2.9%	5.9%	39.2%	52.0%
Finanšu rādītāju analīze	0.0%	2.0%	7.8%	37.3%	52.9%
Pamatīdzekļu pārvaldīšanai	2.9%	2.9%	3.9%	29.4%	60.8%
Importēšanas/Eksportēšanas iespējas no citām sistēmām	0.0%	0.0%	4.9%	53.9%	41.2%
Digitālu dokumentu augšuplāde	0.0%	2.0%	2.9%	37.3%	57.8%
Revīzijas procedūru racionalizēšana	0.0%	0.0%	5.9%	51.0%	43.1%
Datu integritātes un precizitātes uzlabošana	0.0%	2.0%	3.9%	43.1%	51.0%
Samazināts audita laiks un pūles pie procesiem	0.0%	2.9%	6.9%	36.3%	53.9%

**1. attēls.** Cik lielā mērā var uzlaboties grāmatvedības procesu kvalitāte, ieviešot automatizētus procesus? (Avots: autores apkopojums)

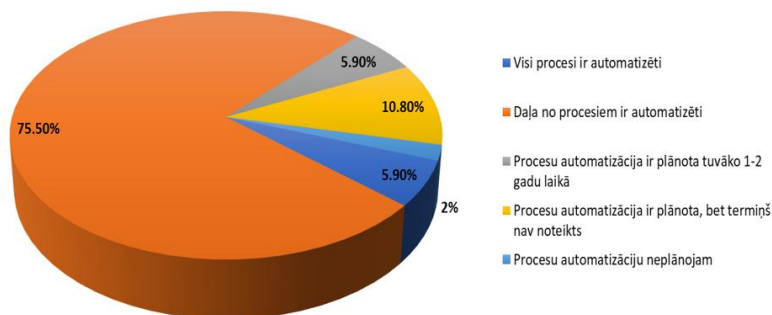

**2. attēls.** Pēc jūsu domām, kāds ir automatizācijas līmenis Jūsu uzņēmumā grāmatvedības procesiem? (Avots: autores apkopojums)

Pētījums atklāj, ka respondentiem atbildot uz jautājumu – par automatizācijas ietekmi uz kvalitāti un kādā līmenī ir automatizācijas procesi uzņēmumos visvairāk respondentu atzīmēja ka, ieviešot automatizāciju uzlabosies rēķinu izrakstīšana un nosūtīšana tīmeklī, atskaišu izveidošana un integrācija. Kā arī inventarizācijas datu apkopošana un noliktavas preču kustības analīzes. Būtiska loma tika pievērsta dokumentu digitalizācijai. Apkopojot datus par vispārējo automatizācijas līmeni uzņēmumos redzam, ka lielākā daļa procesu uzņēmumos ir automatizēti.



## Secinājumi

Grāmatvežu aptaujas laikā darba autore konstatēja, ka tehnoloģiskā infrastruktūra, atbilstoša personāla apmācība un atbalsts ir divi galvenie faktori, kas ir visnozīmīgākie sekmīgas automatizācijas ieviešanā. Grāmatveži norādīja uz to, ka manuālo darba pienākumu samazinājums ir bijis viens no vissvarīgākajiem faktoriem kas vecinās grāmatvedības procesu automatizāciju. Lielākā daļa grāmatvedības procesu ir pilnībā vai daļēji automatizējami kas ietaupa laiku un darba resursus, kā arī samazina kļūdu risku un nodrošina precīzākus un ātrākus grāmatvedības procesus.

### Izmantotās literatūras un informācijas avotu saraksts

ACCA (2020). *Technology is just one of many forces coming together to reshape the future of careers in accountancy.* [https://www.accaglobal.com/gb/en/professional-insights/pro-accountants-the-future/future\\_ready\\_2020s.html](https://www.accaglobal.com/gb/en/professional-insights/pro-accountants-the-future/future_ready_2020s.html)

ACCA (2018a). *Accountancy futures The human factor.* [https://www.accaglobal.com/content/dam/ACCA\\_Global/Members/acca-caanz/AF-17-interactive-125.pdf](https://www.accaglobal.com/content/dam/ACCA_Global/Members/acca-caanz/AF-17-interactive-125.pdf)

ACCA (2018b). *Embracing robotic automation during the evolution of finance.* [https://accaglobal.com/content/dam/ACCA\\_Global/professional-insights/embracing-robotics/Embracing%20robotic%20automation.pdf](https://accaglobal.com/content/dam/ACCA_Global/professional-insights/embracing-robotics/Embracing%20robotic%20automation.pdf)

Adrianto, C. (2022). *The impact of automation on the accounting profession.* Pieejams: [https://www.researchgate.net/publication/370838269\\_The\\_Impact\\_of\\_Automation\\_on\\_the\\_Accounting\\_Profession\\_-\\_The\\_Perspective\\_of\\_Indonesian\\_Accountants](https://www.researchgate.net/publication/370838269_The_Impact_of_Automation_on_the_Accounting_Profession_-_The_Perspective_of_Indonesian_Accountants)

Ayinla, B. (2024). The role of robotic process automation. *Engineering Science & Technology Journal* 5(2), 427-447. <https://doi.org/10.51594/estj.v5i2.804>

Deloitte. (2018). *Internal controls over financial reporting considerations for developing and implementing bots.* <https://www2.deloitte.com/content/dam/Deloitte/us/Documents/audit/us-audit-internal-controls-over-financial-reporting-considerations-for-developing-and-implementing-bots.pdf>

Doguc, O. (2020). Robot process automation (RPA). *Advances in E-Business Research*, 469-492. <https://doi.org/10.4018/978-1-7998-1121-1.ch021>

Hazar, H., & Toplu, C. (2023). The use of robotic process automation in accounting. *Prizren Social Science Journal*, 7(3). <https://doi.org/10.32936/pssj.v7i3.481>

Stoop, I., & Harrison, E. (2012). Classification of surveys. *Handbook of Survey Methodology for the Social Sciences*, 7-21. [https://doi.org/10.1007/978-1-4614-3876-2\\_2](https://doi.org/10.1007/978-1-4614-3876-2_2)

Richardson, J. (2011). *Introduction to Accounting.* <https://oasis.col.org/server/api/core/bitstreams/4ed64a66-be62-47a8-911f-82fffe14dc9b/content>

KANTAR (2019). *Dzimuma diskriminācijas vērtējums darba vidē Latvijas un citu ES valstu iedzīvotāju vidū.* <https://www.kantar.lv/tnsab60/ka-dzimuma-diskriminaciju-un-paveikto-daudzveidibas-veicinasana-darba-vide-verte-latvijas-un-citu-es-valstu-iedzivotaji/>

Langmann, C., & Kokina, J. (2021). RPA in accounting. *Robotic Process Automation*, 243-262. <https://doi.org/10.1515/9783110676693-013>

Leinonen Group (2023). *Leinonen.* <https://leinonen.eu/articles/modern-accounting-trends/>



LIAA (2020). *Mazā, vidējā komersanta statusa noteikšana.*  
<https://www.liaa.gov.lv/lv/programmas/noderigi/maza-videja-komersanta-statuss>

Romashko, O., Melnyk, N., Moskaliuk, H., & Volchek, R. (2023). The impact of accounting on the business climate in the EU countries. *Academic Journal of Interdisciplinary Studies*, 12(6).  
<https://doi.org/10.3694/ajis-2023-0154>

Schneider, S. (2021). The classification of education in surveys: a generalized framework for ex-post harmonization. *Quality & Quantity*, 56(3).  
<https://www.researchgate.net/publication/350638926> *The classification of education in surveys a generalized framework for ex-post harmonization*

WEF (2023). *Future of jobs report.* [https://www3.weforum.org/docs/WEF\\_Future\\_of\\_Jobs\\_2023.pdf](https://www3.weforum.org/docs/WEF_Future_of_Jobs_2023.pdf)

## Pielikumi

### Grāmatvežu aptaujas anketa

Labdien!

Mani sauc Līga Prancāne, esmu Biznesa vadības 2. kursa studente Ekonomikas un kultūras augstskolā un maģistra darba ietvaros veicu grāmatvežu aptaujas un intervijas par automatizācijas procesa ietekmi uz grāmatvedības procesu kvalitātes uzlabošanu Latvijas uzņēmumos. Lūdzu jūs kā jomas ekspertus vēltīt līdz 10 minūtēm laika, lai atbildētu uz jautājumiem un dalītos savā pieredzē. Jūsu sniegtās atbildes ir anonīmas un tās tiks izmantotas apkopotā veidā.

#### 1. Jūsu vecums?

- a) 18-25
- b) 26-35
- c) 36-45
- d) 45+65
- e) 65+

#### 2. Lūdzu, norādiet savu dzimumu?

- a) Sieviete
- b) Vīrietis
- c) Cits

#### 3. Kāda Jums ir pēdējā pabeigtā izglītība?

- a) Vidēja izglītība
- b) Vidēja profesionālā izglītība
- c) Koledžas vai bakalaura izglītība
- d) Maģistrs vai doktora grāds

**4. Cik gadus jau strādājat par grāmatvedi?**

- a) 1-5
- b) 6-10
- c) Virs 10

**5. Kuram no šiem statusiem atbilst uzņēmums, kurā Jūs strādājat?**

- a) Mikro uzņēmums
- b) Mazais uzņēmums
- c) Vidējais uzņēmums
- d) Lielais uzņēmums

**6. Jūs esat?**

- a) Ārpalpojuma grāmatvedis
- b) Uzņēmuma grāmatvedis

**Ja jūs esat ārpalpojuma grāmatvedis tad turpinājumā , lūdzu sniegt atbildes par uzņēmumu kurā jūs strādājat!**

**7. Vai Jūs ziniet kas ir procesu automatizācija?**

- a) Jā, bet mūsu uzņēmumā netika ieviesta
- b) Jā, daļa mūsu procesu tiek veikti automātiski
- c) Esmu dzirdējis, bet neizmantojam
- d) Nezinu un neesmu dzirdējis
- e) Cits (lūdzu, norādiet)

**8. Ja jūsu uzņēmumā tika ieviesti automatizēti procesi, tad kādus labumus tie dod?**

*Lūdzu, vērtējumu sniedziet skalā no 1 līdz 5, kur "1-pilnībā nepiekrītu" un "5-pilnībā piekrītu"!*

	1-pilnībā nepiekrītu	2- drīzāk nepiekrītu	3-ne piekrītu, ne nepiekrītu	4- drīzāk piekrītu	5 -Pilnībā piekrītu
Uzlabota kvalitāte/precizitāte	<input type="checkbox"/>	<input type="checkbox"/>	<input type="checkbox"/>	<input type="checkbox"/>	<input type="checkbox"/>
Spēja strādāt 24/7	<input type="checkbox"/>	<input type="checkbox"/>	<input type="checkbox"/>	<input type="checkbox"/>	<input type="checkbox"/>
Uzlabota produktivitāte	<input type="checkbox"/>	<input type="checkbox"/>	<input type="checkbox"/>	<input type="checkbox"/>	<input type="checkbox"/>
Izmaksu samazināšana	<input type="checkbox"/>	<input type="checkbox"/>	<input type="checkbox"/>	<input type="checkbox"/>	<input type="checkbox"/>
Īsāks datu apkopošanas laiks	<input type="checkbox"/>	<input type="checkbox"/>	<input type="checkbox"/>	<input type="checkbox"/>	<input type="checkbox"/>
Manuālo darbu samazināšanās	<input type="checkbox"/>	<input type="checkbox"/>	<input type="checkbox"/>	<input type="checkbox"/>	<input type="checkbox"/>
Nodrošināta labāka vadības informācija	<input type="checkbox"/>	<input type="checkbox"/>	<input type="checkbox"/>	<input type="checkbox"/>	<input type="checkbox"/>
Mazāks pieļauto kļūdu skaits	<input type="checkbox"/>	<input type="checkbox"/>	<input type="checkbox"/>	<input type="checkbox"/>	<input type="checkbox"/>
Optimāla debitoru/kreditoru	<input type="checkbox"/>	<input type="checkbox"/>	<input type="checkbox"/>	<input type="checkbox"/>	<input type="checkbox"/>

pārvaldība					
Datu integrācija un atbilstība	<input type="checkbox"/>	<input type="checkbox"/>	<input type="checkbox"/>	<input type="checkbox"/>	<input type="checkbox"/>
Atvieglots revīzijas process	<input type="checkbox"/>	<input type="checkbox"/>	<input type="checkbox"/>	<input type="checkbox"/>	<input type="checkbox"/>
Optimizēti darba resursi	<input type="checkbox"/>	<input type="checkbox"/>	<input type="checkbox"/>	<input type="checkbox"/>	<input type="checkbox"/>
Lielāka drošība	<input type="checkbox"/>	<input type="checkbox"/>	<input type="checkbox"/>	<input type="checkbox"/>	<input type="checkbox"/>

**9. Pēc Jūsu domām kāds ir automatizācijas līmenis Jūsu uzņēmumā grāmatvedības procesiem?**

- Visi procesi ir automatizēti
- Daļa no procesiem ir automatizēti
- Procesu automatizācija ir plānota tuvāko 1-2 gadu laikā
- Procesu automatizācija ir plānota, bet termiņš nav noteikts
- Procesu automatizāciju neplānojam

**10. Cik augstā līmenī, jūsu uzņēmumā jau notiek grāmatvedības procesu automatizācija?**

*Lūdzu, vērtējumu sniedziet skalā no 1 līdz 5, kur "1-ļoti zemā" un "5-ļoti augstā"!*

Grāmatvedības procesi	1-ļoti zemā	2 zemā	3-vidēji	4 augstā	5-ļoti augstā	Nezinu/grūti pateikt	Procesu automatizācija nenotiek
Statistikas datu apkopošana un iesniegšana CSP	<input type="checkbox"/>	<input type="checkbox"/>	<input type="checkbox"/>	<input type="checkbox"/>	<input type="checkbox"/>	<input type="checkbox"/>	<input type="checkbox"/>
Datu apmaiņa ar banku sistēmām	<input type="checkbox"/>	<input type="checkbox"/>	<input type="checkbox"/>	<input type="checkbox"/>	<input type="checkbox"/>	<input type="checkbox"/>	<input type="checkbox"/>
Noliktavas preču kustības analīze	<input type="checkbox"/>	<input type="checkbox"/>	<input type="checkbox"/>	<input type="checkbox"/>	<input type="checkbox"/>	<input type="checkbox"/>	<input type="checkbox"/>
Inventarizācijas datu apkopošana un salīdzināšana	<input type="checkbox"/>	<input type="checkbox"/>	<input type="checkbox"/>	<input type="checkbox"/>	<input type="checkbox"/>	<input type="checkbox"/>	<input type="checkbox"/>
Izmaksu sadale pa budžetiem	<input type="checkbox"/>	<input type="checkbox"/>	<input type="checkbox"/>	<input type="checkbox"/>	<input type="checkbox"/>	<input type="checkbox"/>	<input type="checkbox"/>
Kases datu apmaiņa – e kasi	<input type="checkbox"/>	<input type="checkbox"/>	<input type="checkbox"/>	<input type="checkbox"/>	<input type="checkbox"/>	<input type="checkbox"/>	<input type="checkbox"/>
Debitoru , Kreditoru pārvaldība	<input type="checkbox"/>	<input type="checkbox"/>	<input type="checkbox"/>	<input type="checkbox"/>	<input type="checkbox"/>	<input type="checkbox"/>	<input type="checkbox"/>
Klientu rēķinu izrakstīšana un nosūtīšana tīmeklī	<input type="checkbox"/>	<input type="checkbox"/>	<input type="checkbox"/>	<input type="checkbox"/>	<input type="checkbox"/>	<input type="checkbox"/>	<input type="checkbox"/>
Atskaišu izveidošana un importēšana VID sistēmā	<input type="checkbox"/>	<input type="checkbox"/>	<input type="checkbox"/>	<input type="checkbox"/>	<input type="checkbox"/>	<input type="checkbox"/>	<input type="checkbox"/>
Starp uzņēmumu salīdzināšanās	<input type="checkbox"/>	<input type="checkbox"/>	<input type="checkbox"/>	<input type="checkbox"/>	<input type="checkbox"/>	<input type="checkbox"/>	<input type="checkbox"/>
Algu aprēķins un izmaksas	<input type="checkbox"/>	<input type="checkbox"/>	<input type="checkbox"/>	<input type="checkbox"/>	<input type="checkbox"/>	<input type="checkbox"/>	<input type="checkbox"/>
Finanšu rādītāju analīze	<input type="checkbox"/>	<input type="checkbox"/>	<input type="checkbox"/>	<input type="checkbox"/>	<input type="checkbox"/>	<input type="checkbox"/>	<input type="checkbox"/>

Pamatlīdzekļu pārvaldīšanai	<input type="checkbox"/>	<input type="checkbox"/>	<input type="checkbox"/>	<input type="checkbox"/>	<input type="checkbox"/>	<input type="checkbox"/>	<input type="checkbox"/>
Importēšanas/Eksportēšanas iespējas no citām sistēmām	<input type="checkbox"/>	<input type="checkbox"/>	<input type="checkbox"/>	<input type="checkbox"/>	<input type="checkbox"/>	<input type="checkbox"/>	<input type="checkbox"/>
Digitālu dokumentu augšuplāde	<input type="checkbox"/>	<input type="checkbox"/>	<input type="checkbox"/>	<input type="checkbox"/>	<input type="checkbox"/>	<input type="checkbox"/>	<input type="checkbox"/>
Audita datu uzraudzība un uzņēmējdarbības risku izvērtēšana	<input type="checkbox"/>	<input type="checkbox"/>	<input type="checkbox"/>	<input type="checkbox"/>	<input type="checkbox"/>	<input type="checkbox"/>	<input type="checkbox"/>

**11. Kā jūs uztverat automatizācijas ietekmi uz darba lomām un pienākumiem grāmatveža profesijā?**

- Pozitīva ietekme, darba apjoms var būtiski samazināties
- Neitrāla ietekme, darba apjoms nevar būtiski samazināties
- Negatīva ietekme, samazināsies pieprasījums pēc grāmatvedības speciālistiem
- Nezinu

**12. Kādas izmaiņas var sagaidīt grāmatvedības profesijā paaugstinoties automatizācijai?**

*Lūdzu, vērtējumu sniedziet skalā no 1 līdz 5, kur "1-pilnībā nepiekrītu" un "5-pilnībā piekrītu"!*

	1-pilnībā nepiekrītu	2-drīzāk nepiekrītu	3-ne piekrītu, ne nepiekrītu	4- drīzāk piekrītu	5-pilnībā piekrītu
Mazāks manuālais darbs	<input type="checkbox"/>	<input type="checkbox"/>	<input type="checkbox"/>	<input type="checkbox"/>	<input type="checkbox"/>
Pastiprināta uzmanība stratēģiskai analīzei un lēmumu pieņemšanai	<input type="checkbox"/>	<input type="checkbox"/>	<input type="checkbox"/>	<input type="checkbox"/>	<input type="checkbox"/>
Augstāks prasību līmenis	<input type="checkbox"/>	<input type="checkbox"/>	<input type="checkbox"/>	<input type="checkbox"/>	<input type="checkbox"/>
Grāmatvedis kļūs par uzņēmuma konsultantu, finanšu ekspertu	<input type="checkbox"/>	<input type="checkbox"/>	<input type="checkbox"/>	<input type="checkbox"/>	<input type="checkbox"/>
Palielināta sadarbība ar IT speciālistiem	<input type="checkbox"/>	<input type="checkbox"/>	<input type="checkbox"/>	<input type="checkbox"/>	<input type="checkbox"/>

**13. Kādi, Jūsaprāt, ir galvenie faktori, kas nosaka veiksmīgu automatizētu procesu ieviešanu grāmatvedības praksē?**

- Tehnoloģiskā infrastruktūra
- Organizācijas kultūra un gatavība pārmaiņām
- Skaidrs stratēģiskais redzējums un mērķi
- Atbilstoša personāla apmācība un atbalsts
- Efektīva pārvaldība un uzraudzība
- Cita (lūdzu, norādiet)

14. **Kāda līmeņa apmācība vai kvalifikācijas paaugstināšana, jūsuprāt, ir nepieciešama grāmatvežiem, lai efektīvi izmantotu automatizācijas procesu tehnoloģiju?**

- a) 2 mēnešu kursi optimālajā līmenī
- b) Mērena apmācība ar pastāvīgu atbalstu
- c) Plašas apmācības un sertifikācijas programmas
- d) Man nav nepieciešamas papildus apmācības

15. **Cik lielā mērā var uzlaboties grāmatvedības procesu kvalitāte ieviešot automatizētus procesus?**

*Lūdzu, vērtējumu sniedziet skalā no 1 līdz 5, kur "1-nevar uzlaboties" un "5-ievērojami uzlabosies"!*

Grāmatvedības procesi	1 - nevar uzlaboties	2 - daļēji nevar uzlaboties	3 - neitrāli	4 - daļēji	5 - ievērojami uzlabosies
Statistikas datu apkopošana un iesniegšana CSP	<input type="checkbox"/>	<input type="checkbox"/>	<input type="checkbox"/>	<input type="checkbox"/>	<input type="checkbox"/>
Datu apmaiņa ar banku sistēmām	<input type="checkbox"/>	<input type="checkbox"/>	<input type="checkbox"/>	<input type="checkbox"/>	<input type="checkbox"/>
Noliktavas preču kustības analīze	<input type="checkbox"/>	<input type="checkbox"/>	<input type="checkbox"/>	<input type="checkbox"/>	<input type="checkbox"/>
Inventarizācijas datu apkopošana un salīdzināšana	<input type="checkbox"/>	<input type="checkbox"/>	<input type="checkbox"/>	<input type="checkbox"/>	<input type="checkbox"/>
Izmaksu sadale pa budžetiem	<input type="checkbox"/>	<input type="checkbox"/>	<input type="checkbox"/>	<input type="checkbox"/>	<input type="checkbox"/>
Kases datu apmaiņa – e kasi	<input type="checkbox"/>	<input type="checkbox"/>	<input type="checkbox"/>	<input type="checkbox"/>	<input type="checkbox"/>
Debitoru , Kreditoru pārvaldība	<input type="checkbox"/>	<input type="checkbox"/>	<input type="checkbox"/>	<input type="checkbox"/>	<input type="checkbox"/>
Klientu rēķinu izrakstīšana un nosūtīšana tīmeklī	<input type="checkbox"/>	<input type="checkbox"/>	<input type="checkbox"/>	<input type="checkbox"/>	<input type="checkbox"/>
Atskaišu izveidošana un importēšana VID sistēmā	<input type="checkbox"/>	<input type="checkbox"/>	<input type="checkbox"/>	<input type="checkbox"/>	<input type="checkbox"/>
Starp uzņēmumu salīdzināšanās	<input type="checkbox"/>	<input type="checkbox"/>	<input type="checkbox"/>	<input type="checkbox"/>	<input type="checkbox"/>
Algu aprēķins un izmaksas	<input type="checkbox"/>	<input type="checkbox"/>	<input type="checkbox"/>	<input type="checkbox"/>	<input type="checkbox"/>
Finanšu rādītāju analīze	<input type="checkbox"/>	<input type="checkbox"/>	<input type="checkbox"/>	<input type="checkbox"/>	<input type="checkbox"/>
Pamatlīdzekļu pārvaldīšanai	<input type="checkbox"/>	<input type="checkbox"/>	<input type="checkbox"/>	<input type="checkbox"/>	<input type="checkbox"/>
Importēšanas/Eksportēšanas iespējas no citām sistēmām	<input type="checkbox"/>	<input type="checkbox"/>	<input type="checkbox"/>	<input type="checkbox"/>	<input type="checkbox"/>
Digitālu dokumentu augšuplāde	<input type="checkbox"/>	<input type="checkbox"/>	<input type="checkbox"/>	<input type="checkbox"/>	<input type="checkbox"/>
Revīzijas procedūru racionalizēšana	<input type="checkbox"/>	<input type="checkbox"/>	<input type="checkbox"/>	<input type="checkbox"/>	<input type="checkbox"/>
Datu integritātes un precizitātes uzlabošana	<input type="checkbox"/>	<input type="checkbox"/>	<input type="checkbox"/>	<input type="checkbox"/>	<input type="checkbox"/>
Samazināts audita laiks un pūles pie procesiem	<input type="checkbox"/>	<input type="checkbox"/>	<input type="checkbox"/>	<input type="checkbox"/>	<input type="checkbox"/>

**PALDIES !**



## Rita Vidže. KORPORATĪVĀS SOCIĀLĀS ATBILDĪBAS IETEKME UZ KLIENTU LOJALITĀTI MAZUMTIRDZniecības uzņēmumos Latvijā

*Ekonomikas un kultūras augstskola  
Maģistra studiju programma "Biznesa vadība"*

*E-pasts: ritavidze@gmail.com*

*Zinātniskā vadītāja: Dr.phil., profesore Velga Vēvere*

### Anotācija

**Pētījuma aktualitāte:** Korporatīvā sociālā atbildība (KSA) mūsdienās ir kļuvusi par ļoti nozīmīgu biznesa sastāvdaļu. KSA tiek raksturota kā: "Brīvprātīga rīcības filozofija un uzņēmējdarbības vērtību apliecināšana sabiedrībai, veidojot attiecības starp uzņēmējiem, uzņēmumiem un ietekmes auditorijām, kas ietver ilgtspējīgu attīstību un resursu saglabāšanu nākamajām paaudzēm" (Latvijas darba devēju konfederācija, 2023), un pēc Hārvardas Biznesa skolas datiem, "77% patērētāju ir motivēti pirkt no uzņēmumiem, kas ir apņēmušies padarīt pasauli labāku" (Harvard Business School, 2021a). Dati norāda uz to, ka uzņēmumi, kas seko KSA principiem un iekļauj tos uzņēmuma stratēģiskajos plānos, var gūt ievērojamas priekšrocības klientu piesaistīšanā un lojālas klientu bāzes izveidošanā, taču daļa no lielākajiem mazumtirdzniecības uzņēmumiem Latvijā ziņojumus par KSA aktivitātēm savā uzņēmumā neveido. Tāpēc ir būtiski veikt pētījumu par to kādas KSA aktivitātes ietekmē klientu lojalitāti mazumtirdzniecības uzņēmumos Latvijā.

**Pētījuma mērķis:** Identificēt korporatīvās sociālās atbildības aktivitātes, kas ietekmē klientu lojalitāti mazumtirdzniecības uzņēmumos Latvijā.

**Pētījuma metodes:** Pētījumā tika izmantotas šīs datu ieguves metodes: dokumentu analīze, sekundāro datu analīze, mediju monitorings, anketēšana. Tika izmantotas šīs datu apstrādes metodes: bibliometriskā analīze, dinamikas rindu analīze, vidējo lielumu aprēķināšana, biežumu analīze, grafiskā analīze, ranžēšana.

**Sasniegtie rezultāti:** Izpētīta teorētiskā bāze par KSA nozīmīgumu un mūsdienu aktualitātēm. Ar anketēšanas palīdzību noskaidrots kādas KSA aktivitātes respondenti mazumtirdzniecības uzņēmumos Latvijā vērtē visaugstāk un kā tās ietekmē klientu lojalitāti. Rezultātā tika izstrādātas KSA aktivitāšu pilnveidošanas rekomendācijas mazumtirdzniecības uzņēmumiem Latvijā.

*Atslēgas vārdi: korporatīvā sociālā atbildība; mazumtirdzniecības uzņēmumi; klientu lojalitāte; Latvija.*

### Ievads

Korporatīvā sociālā atbildība (KSA) mūsdienās ir kļuvusi par ļoti nozīmīgu biznesa sastāvdaļu, un pētījuma autores veiktā bibliometriskā analīze liecina, ka arī pētnieku interese par KSA ir ar tendenci pieaugt (SCOPUS, 2023). Latvijas darba devēju konfederācija KSA raksturo kā: "Brīvprātīgu rīcības filozofiju un uzņēmējdarbības vērtību apliecināšanu sabiedrībai, veidojot attiecības starp uzņēmējiem, uzņēmumiem un ietekmes auditorijām, kas ietver ilgtspējīgu attīstību un resursu saglabāšanu nākamajām paaudzēm" (Latvijas darba devēju konfederācija, 2023). Un pēc Hārvardas Biznesa skolas datiem, "77% patērētāju ir motivēti pirkt no uzņēmumiem, kas ir apņēmušies padarīt pasauli labāku"



(Harvard Business School, 2021a). Dati norāda uz to, ka uzņēmumi, kas seko KSA principiem un iekļauj tos uzņēmuma stratēģiskajos plānos, var gūt ievērojamas priekšrocības klientu piesaistīšanā un lojālas klientu bāzes izveidošanā. Taču daļa no lielākajiem mazumtirdzniecības uzņēmumiem Latvijā KSA ziņojumus neveido. Turklāt, līdz ar Lidl veikalu tīkla ienākšanu Latvijas tirgū 2021. gada 15. oktobrī (Lidl, 2021), un konkurences pieaugumu nozarē, mazumtirdzniecības uzņēmumiem Latvijā ir svarīgi piesaistīt klientus un veicināt to lojalitāti uzņēmumiem, un KSA aktivitātes ir viens no instrumentiem kā to īstenot. Tāpēc ir būtiski veikt pētījumu par to kādas KSA aktivitātes ietekmē klientu lojalitāti mazumtirdzniecības uzņēmumos Latvijā.

Pētījuma mērķis bija identificēt korporatīvās sociālās atbildības aktivitātes, kas ietekmē klientu lojalitāti mazumtirdzniecības uzņēmumos Latvijā. Pētījuma mērķa sasniegšanai izvirzīti šādi uzdevumi:

- Izpētīt KSA teorētiskos aspektus;
- Izpētīt mazumtirdzniecības uzņēmumus Latvijā un izvērtēt KSA aktivitātes tajos;
- Izstrādāt anketu un ar tās palīdzību noskaidrot respondentu viedokli par KSA aktivitātēm mazumtirdzniecības uzņēmumos Latvijā un noteikt kuras KSA aktivitātes ietekmē klientu lojalitāti;
- Identificēt nozīmīgākās KSA aktivitātes un izstrādāt KSA aktivitāšu pilnveidošanas rekomendācijas mazumtirdzniecības uzņēmumiem Latvijā.

Pētījuma objekts bija mazumtirdzniecības uzņēmumi Latvijā. Pētījuma priekšmets bija korporatīvās sociālās atbildības ietekme uz klientu lojalitāti. Pētījuma jautājums bija šāds: Kādas korporatīvās sociālās atbildības aktivitātes mazumtirdzniecības uzņēmumos Latvijā ietekmē klientu lojalitāti?

Pētījumā izmantotas šādas datu ieguves metodes:

- Dokumentu analīze;
- Sekundāro datu analīze;
- Mediju monitorings;
- Anketēšana.

Pētījumā izmantotas šādas datu apstrādes metodes:

- Bibliometriskā analīze;
- Dinamikas rindu analīze;
- Vidējo lielumu aprēķināšana;
- Biežumu analīze;
- Grafiskā analīze;
- Ranžēšana.

Pētījuma ierobežojumi:

- Pētījuma periods: pētījums veikts- 2024. gada februāris- aprīlis;
- Anketēšanā piedalījās 248 respondenti;
- Tika pētīti tikai pārtikas mazumtirdzniecības uzņēmumi Latvijā;



- Tika pētīti lielākie pēc apgrozījuma pārtikas mazumtirdzniecības uzņēmumi Latvijā - Rimi Latvia, SIA, Maxima Latvija, SIA, MEGO, SIA, Firma Madara 89, SIA un Lidl Latvija, SIA;
- Pētītais periods par mazumtirdzniecības uzņēmumiem Latvijā- 2016. – 2022. gads.

Pētījuma rezultātu apraksts: Anektēšanas rezultāti atklāja, ka respondenti visaugstāk vērtē KSA ētiskās atbildības aktivitātes, bet viszemāk filantropiskās atbildības aspektus. Turklāt 50% no respondentiem KSA aktivitātes mazumtirdzniecības uzņēmumos Latvijā vērtē apmierinoši. 28% respondenti KSA aktivitātes vērtē labi un ļoti labi, bet 22% respondentu norāda uz nopietniem trūkumiem KSA jomā, sniedzot vērtējumus slikti un ļoti slikti. Rezultātā tika izstrādātas KSA aktivitāšu pilnveidošanas rekomendācijas mazumtirdzniecības uzņēmumiem Latvijā.

### Analītiskais apskats

Korporatīvajai sociālajai atbildībai (KSA) ir liels daudzums definīciju un skaidrojumu. Latvijas darba devēju konfederācija korporatīvo sociālo atbildību raksturo kā: “Brīvprātīgu rīcības filozofiju un uzņēmējdarbības vērtību apliecināšanai sabiedrībai, veidojot attiecības starp uzņēmējiem, uzņēmumiem un ietekmes auditorijām, kas ietver ilgtspējīgu attīstību un resursu saglabāšanu nākamajām paaudzēm” (Latvijas darba devēju konfederācija, 2023). Pētnieki par KSA raksta, ka: “Labi izvērsta korporatīvās sociālās atbildības aktivitātes rada labu reputāciju un veiksmīgu sociālo un videi draudzīgu zīmola tēlu, uzlabo darbinieku darba veiktspēju, veido labākas attiecības ar galvenajām ieinteresētajām personām, samazina izmaksas un izvairās no reglamentējošām sankcijām, kas kopumā var nodrošināt uzņēmumam konkurences priekšrocības un nodrošināt augstāku rentabilitāti” (Nechaev & Hain, 2023, 3).

Savukārt grāmatu autori pauž viedokli ka KSA mūsdienās ir kļuvusi par neatņemamu uzņēmuma stratēģijas un ikdienas darbību sastāvdaļu (Chandler, 2022) un piedēvē KSA holistisku pieeju, kas var atsaukties gan uz uzņēmuma mērķu izpildi, gan attīstības rezultātiem (Vevere & Svirina, 2020). Pēc pētījuma autores domām visi šie skaidrojumi ietver ļoti būtiskus atslēgas vārdus, kas ir saistīti ar uzņēmuma attīstīšanu tādā virzienā, lai ilgtermiņā sniegtu labumu visām iesaistītajām pusēm, veicinātu ilgtspēju un vides saglabāšanas funkciju un kopvērtējumā radītu pozitīvu uzņēmuma tēlu ilgtermiņā.

Korporatīvā sociālā atbildība kā jēdzienu sevi pieteica 1950. gados saistībā ar sociālo un vides aizsardzības jautājumu aktualizēšanos sabiedrībā (Latapí-Agudelo, 2019). KSA tiek iedalīta četrās kategorijās, kas kalpo kā vadlīnijas uzņēmumu darbības nodrošināšanai saskaņā ar KSA (sk. 1. tabulu).

**1.tabula.** KSA četras kategorijas (Avots: autores apkopojums no Harvard Business School, 2021b)

N.p.k.	Kategorija	Iespējamās darbības
1.	Atbildība pret vidi	- Kaitīgās prakses samazināšana; - Enerģijas resursu patēriņa regulēšana; - Negatīvās ietekmes kompensēšana.
2.	Ētiskā atbildība	- Ētiskas un godīgas uzvedības praktizēšana pret visām iesaistītajām pusēm; - Godīga atalgojuma ieviešana uzņēmumā; - Iegādāto / piedāvāto produktu, sastāvdaļu, materiālu vai komponentu atbilstība brīvās tirdzniecības standartiem.
3.	Filantropiskā atbildība	- Iesaiste labdarības vai bezpeļņas projektos; - Labdarības fondu izveide.

4.	Ekonomiskā atbildība	<ul style="list-style-type: none"> <li>- Godīga nodokļu politika uzņēmumā;</li> <li>- Par mērķi izvirzīt ne tikai palielināt peļņu, bet arī pārliecināties, ka uzņēmējdarbība pozitīvi ietekmē vidi, cilvēkus un sabiedrību.</li> </ul>
----	----------------------	---

Pēc pētījuma autores domām šie punkti raksturo galvenos aspektus pie kuru izpildes uzņēmumam būtu jāstrādā, lai spētu sevi dēvēt par korporatīvi sociāli atbildīgu uzņēmumu.

Veicot bibliometrisko analīzi, iespējams novērot to, ka pētnieku interese par KSA tēmām ir ar tendenci pieaugt, par ko liecina zinātnisko rakstu meklējumu rezultātu apjoms Scopus datu bāzē laika posmā no 1957. gada līdz 2023. gadam (sk. 1.att.).

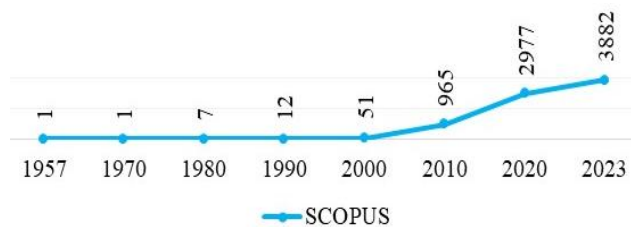

**1.att.** SCOPUS meklējumu un dinamika par KSA tēmām (Avots: autores apkopojums no SCOPUS, 2023)

Iegūtie dati norāda uz tēmas aktualitāti cauri vairākām gadu dekādēm un apstiprina tēmas nozīmīgumu un aktualitāti mūsdienās. Veikto pētījumu rezultāti atspoguļo to, ka korporatīvās sociālās atbildības iniciatīvas pozitīvi ietekmē dažādus ekonomiskos pasākumus, piemēram uzņēmumu konkurences priekšrocības, reputāciju, finanšu rādītājus un patērētāju lojalitāti un apmierinātību (Nguyen u. c., 2023), turklāt ilgtspējīga attīstība ir viens no galvenajiem KSA principu ievērošanas apņemšanās punktiem (González-Morales u. c., 2023). Hārvardas Biznesa skola norāda, ka “77% patērētāju ir motivēti pirkt no uzņēmumiem, kas ir apņēmušies padarīt pasauli labāku, bet 73% investoru uzskata, ka centieni uzlabot vidi un sabiedrību veicina viņu investīciju lēmumus” (Harvard Business School, 2021a). Pēc pētījuma autores domām, šie dati liecina par to, ka uzņēmums, kas seko KSA principiem un iekļauj tos uzņēmuma stratēģiskajos plānos, var gūt ievērojamus ieguvumus veidojot lojālu klientu bāzi un piesaistot investorus.

Pēc Forbes datiem var secināt, ka, ja sociāli atbildīgs uzņēmums saskaņo savas vērtības ar savu klientu vērtībām, tas paver durvis klientu lojalitātei, tāpēc patērētāji visdrīzāk sniegs atbalstu izdarot izvēli par labu konkrētajam uzņēmumam, līdz ar ko uzņēmums paaugstina konkurētspēju nozarē (Forbes, 2022) un šis jautājums starp lielākajiem mazumtirdzniecības uzņēmumiem Latvijā ir aktualizējies līdz ar līdz ar Lidl veikalu tīkla ienākšanu Latvijas tirgū 2021. gada 15. oktobrī (Lidl, 2021). Tāpēc pētījuma autore pētījumā izvēlas analizēt piecus lielākos (pēc uzņēmumu apgrozījuma) pārtikas mazumtirdzniecības nozares uzņēmumus Latvijā laika posmā no 2016. līdz 2022. gadam (sk. 2.att.).

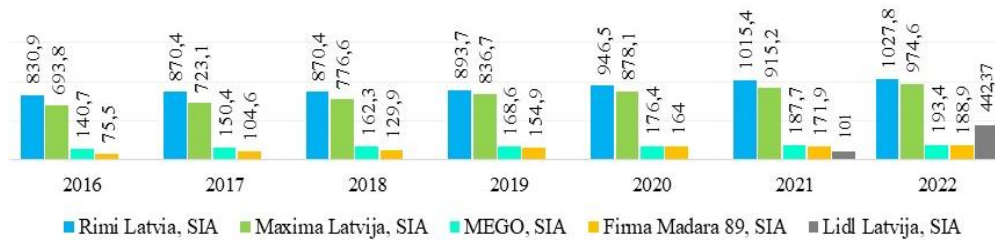

**2.att.** Lielāko mazumtirdzniecības uzņēmumu Latvijā apgrozījums laika posmā 2016–2022. gads (milj. EUR) (Avots: autores apkopojums no Lursoft, 2023a; Lursoft, 2023b; Lursoft, 2023c; Lursoft, 2023d; Lursoft, 2023e)

Pēc pētījuma autores domām mazumtirdzniecības uzņēmumiem Latvijā, jo īpaši tiem uzņēmumiem, kas pārstāv vienu pamatdarbības veidu, kas ir saistīts ar pārtikas tirdzniecību, līdz ar Lidl veikalu tīkla ienākšanu Latvijas tirgū 2021. gada 15. oktobrī (Lidl, 2021) ir jāpieliek papildu pūles, lai piesaistītu klientus izvēlēties viņu pārstāvēto uzņēmumu un izveidotu lojālu klientu bāzi. Tāpēc pētījuma autore veic padziļinātu izpēti uzņēmumu mājaslapās, lai noskaidrotu to vai pētāmie mazumtirdzniecības uzņēmumi Latvijā ir ieviesuši un definējuši KSA politiku savā uzņēmumā, apraksta to mājaslapā un sniedz ziņojumus par KSA izpildi (sk. 2.tabulu).

**2.tabula.** KSA politikas atspoguļojums lielāko mazumtirdzniecības uzņēmumu Latvijā (pēc uzņēmumu apgrozījuma) mājaslapās (Avots: autores apkopojums no Rimi, 2023; Maxima, 2023; Mego, 2023; Top, 2023; Lidl, 2023)

Uzņēmums	KSA politika mājaslapā	
	Ir definēta	Nav definēta
Rimi Latvia, SIA	x	
Maxima Latvija, SIA	x	
MEGO, SIA		x
Firma Madara 89, SIA (Top)		x
Lidl Latvija	x	

Pētījuma autores uzskati sakrīt ar teorētiskajā bāzē izskatītajiem aspektiem, ka KSA aktivitātes, iespējami, ir viens no instrumentiem, kas var radīt pozitīvas sekas uz dažādiem uzņēmējdarbības aspektiem, tajā skaitā klientu lojalitātes rādītājiem. Taču iegūtie dati norāda uz to, ka ne visi lielākie mazumtirdzniecības uzņēmumi Latvijā ir definējuši KSA politiku un strādā pie tās izpildes saskaņā ar Apvienoto Nāciju Organizācijas Globālo līgumu, kas “aicina uzņēmumus attīstīt labas pārvaldības praksi un sociāli atbildīgu rīcību savā uzņēmumā” (Labklājības ministrija, 2020), tāpēc ir būtiski veikt pētījumu lai noskaidrotu vai pastāv sakarība starp KSA pasākumu īstenošanu uzņēmumā un klientu lojalitāti tam.

### Pētījuma metodoloģija

Pētījuma ietvaros tika izstrādāta anketa, kas ļautu noteikt respondentu viedokli par KSA aktivitātēm mazumtirdzniecības uzņēmumos Latvijā ar mērķi identificēt kādas KSA aktivitātes ietekmē klientu lojalitāti. Izstrādātājā anketā tika uzdoti 22 jautājumi, kas sadalīti blokos pēc to satura un formas. Anketā

tika uzdoti jautājumi kas ļautu respondentus sadalīt starp dzimumiem un noteikt respondentu vidējo vecumu un tika izveidots respondentu profils. Tika uzdoti jautājumi, kas ļautu noteikt veikalu apmeklējumu biežumu. Un tika izveidots jautājumu bloks, kas ļautu noteikt KSA kategorijas nozīmīgumu pēc respondentu domām (atbildība pret vidi, ētiskā atbildība, filantropiskā atbildība, ekonomiskā atbildība). Anketā tika iekļauts arī atvērtais jautājums, ļaujot respondentiem paust savu viedokli par to kādas KSA aktivitātes būtu jāveic mazumtirdzniecības uzņēmumos Latvijā. Apkopojot rezultātus tika ranžēti KSA kategoriju bloki pēc to nozīmības, kas ļāva noteikt tās KSA aktivitātes, kas visvairāk ietekmē klientu lojalitāti.

Aptaujā piedalījās 248 respondenti no kuriem 203 respondenti bija sievietes un 45 respondenti bija vīrieši. Un tika noteikts respondentu vidējais vecums, kas sasniedza 33,2 gadus. Anketa tika izstrādāta elektroniskā formātā un bija publiski pieejama datu vākšanas un apkopošanas portālā VisiDati.lv. Uz iegūto anketēšanas rezultātu bāzes tika izstrādātas KSA aktivitāšu pilnveidošanas rekomendācijas mazumtirdzniecības uzņēmumiem Latvijā.

### Pētījuma rezultāti

Anketēšanas pirmajā posmā tika noskaidrota mazumtirdzniecības uzņēmumu Latvijā apmeklētības rādītāji. Iegūtie rezultāti norāda uz to, ka respondenti visbiežāk apmeklētais mazumtirdzniecības uzņēmums Latvijā ir Rimi (Rimi Latvia, SIA) uz ko norāda 52% respondentu. Savukārt visretāk apmeklēto veikalu sarakstā ierindojās Top (Firma Madara 89, SIA), ko ļoti reti apmeklē vai nekad neapmeklē 20% respondentu (sk. 3.att.).

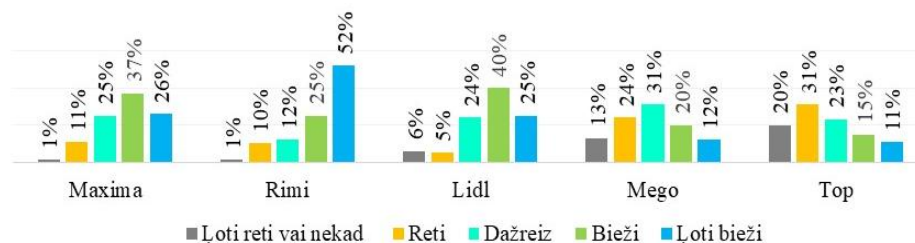

**3.att.** Respondentu vērtējumi par mazumtirdzniecības uzņēmumu apmeklējumu biežumu (Avots: autores veiktās anketēšanas rezultātu apkopojums)

Pētījumā iegūtie dati par mazumtirdzniecības uzņēmumu apmeklētību, summējot “biežu” un “ļoti biežu” apmeklētību, norāda, ka, Rimi (Rimi Latvia, SIA) izvēlas 77%, Lidl (Lidl Latvija, SIA) izvēlas 65%, Maxima (Maxima Latvija, SIA) izvēlas 63%, Mego (MEGO, SIA) izvēlas 32%, bet Top (Firma Madara 89, SIA) izvēlas 26% respondentu. No tā iespējams secināt, ka Rimi, Lidl un Maxima uzrāda vismaz divreiz lielāku apmeklētības rādītāju nekā to konkurenti Mego un Top.

Veicot anketēšanas otro posmu, pētījuma autore noskaidroja to, kā respondenti vērtē korporatīvās sociālās atbildības pasākumus, kas tiek veikti mazumtirdzniecības uzņēmumos Latvijā (sk. 3.tabulu).

**3.tabula.** KSA aktivitāšu ranžējums pēc pozitīvo vērtējumu īpatsvara (Avots: autores veiktās anketēšanas rezultātu apkopojums)

KSA kategorija	KSA aktivitāte	Vērtējumi			Pozitīvo vērtējumu īpatsvars C - A - B
		Ļoti nesvarīgi (1); Nesvarīgi (2) (A)	Ne svarīgi, ne nesvarīgi (3) (B)	Svarīgi (4); Ļoti svarīgi (5) (C)	
Ētiskā atbildība	Godīga cenu politika	0%	2%	98%	96%
Ētiskā atbildība	Ētiskas un godīgas uzvedības praktizēšana pret klientiem	0%	4%	96%	92%
Ētiskā atbildība	Ētiskas un godīgas uzvedības praktizēšana pret darbiniekiem un citām iesaistītajām pusēm	0%	8%	92%	84%
Ekonomiskā atbildība	Godīga nodokļu politika uzņēmumā	2%	10%	88%	76%
Ētiskā atbildība	Godīga atalgojuma sistēma uzņēmumā	2%	12%	86%	72%
Ētiskā atbildība	Piedāvāto produktu atbilstība brīvās tirdzniecības standartiem	5%	12%	83%	66%
Atbildība pret vidi	Uzņēmuma negatīvās ietekmes kompensēšana	2%	16%	82%	64%
Ekonomiskā atbildība	Godprātīga KSA principu ievērošana uzņēmumā	3%	15%	82%	64%
Atbildība pret vidi	Kaitīgās prakses samazināšana uzņēmumā	9%	20%	71%	42%
Atbildība pret vidi	Klientiem sniegtā iespēja nodot baterijas vai citas tehniskās iekārtas tirdzniecības vietā	9%	22%	69%	38%
Atbildība pret vidi	Enerģijas resursu patēriņa regulēšana uzņēmumā	11%	25%	64%	28%
Filantropiskā atbildība	Uzņēmuma iesaiste labdarības vai bezpeļņas projektos	5%	32%	63%	26%
Filantropiskā atbildība	Uzņēmuma labdarības fondu izveide	5%	38%	57%	14%
Ētiskā atbildība	Sankcijām pakļauto valstu preču izņemšanas no sortimenta	24%	23%	53%	6%
Filantropiskā atbildība	Beztermiņa labdarības pasākumi tirdzniecības vietā	14%	33%	53%	6%

Ranžējot KSA veidus pēc to nozīmības tika iegūti rezultāti, kas norāda uz to, ka respondenti kopvērtējumā novērtē ētisko atbildību kā nozīmīgāko KSA kategoriju, savukārt filantropisko atbildību kā vismaznozīmīgāko KSA kategoriju. Bet respondentu vērtējumi par KSA pasākumiem un to ievērošanu mazumtirdzniecības uzņēmumos liecina par neviennozīmīgiem rezultātiem. 50%

respondentu KSA pasākumus vērtē kā apmierinošus, 28% kā labus vai ļoti labus un 22% kā vājus vai ļoti vājus (sk. 4.att.).



**4.att.** Respondentu vērtējums par KSA pasākumiem mazumtirdzniecības uzņēmumos Latvijā (Avots: autores veiktās anketēšanas rezultātu apkopojums)

Dati norāda uz to, ka mazumtirdzniecības uzņēmumiem Latvijā ir vieta izaugsmei KSA principu ievērošanā un praktizēšanā uzņēmumā. Šo uzskatu pastiprina respondentu paustais viedoklis par to kādus KSA pasākumus būtu jāievieš mazumtirdzniecības uzņēmumos Latvijā (sk. 5.att.).



**5.att.** Respondentu uzskati par to kādi korporatīvās sociālās atbildības pasākumi būtu jāievieš mazumtirdzniecības uzņēmumos Latvijā (Avots: autores veiktās anketēšanas rezultātu apkopojums)

24% respondenti brīvajā jautājumā norāda, ka viņi vēlētos, lai arī mazpilsētu tirdzniecības vietās būtu iespēja veikt ziedojumus naudas izteiksmē, nodot labā stāvoklī esošās nevajadzīgās mantas labdarībai vai nodot bīstamos atkritumus (piemēram, baterijas). 20% respondenti uzsver, ka vēlētos, lai mazumtirdzniecības uzņēmumi veiktu lielākus ziedojumus no savas puses, ne vien lūdzot to darīt saviem klientiem, jo uzskata, ka nereti pērkot preces konkrētajā uzņēmumā un pēcāk tās ievietojot ziedošanas kastēs, klienti veicina uzņēmuma peļņas rādītājus, turklāt respondentiem bieži vien nav pārliecības par to, kas ir ziedoto mantu mērķauditorija. 12% respondentu uzskata, ka uzņēmumiem būtu jābūt caurspīdīgākai KSA politikai, jo viņiem trūkst uzticamības tam, ka visas aprakstītās darbības tiek godprātīgi veiktas. 5% respondentu vēlētos redzamākas atskaites par KSA aktivitātēm un veiktajiem pasākumiem. 3% respondentu uzskata, ka jāpastiprina un jāuzrauga atkritumu šķirošanas politika mazumtirdzniecības uzņēmumos Latvijā. Uz iegūtajiem rezultātiem pētījuma autore ir izstrādājusi KSA aktivitāšu pilnveidošanas rekomendācijas mazumtirdzniecības uzņēmumiem Latvijā (sk. 4.tabulu).

**4.tabula.** KSA aktivitāšu pilnveidošanas rekomendācijas mazumtirdzniecības uzņēmumiem Latvijā  
(Avots: autore izstrādātas rekomendācijas)

KSA kategorija	Veicamās darbības
Ētiskā atbildība	- Sniegt publisku darbību atskaiti un pārskatu, par uzņēmuma ētiskās atbildības aspektiem un veiktajām; darbībām ar mērķi parādīt, ka veiktās KSA aktivitātes nav tikai formalitāte, bet tiek realizēta praksē.
Atbildība pret vidi	- Sniegt publisku darbību atskaiti un pārskatu, par uzņēmuma atbildības pret vidi aspektiem un veiktajām darbībām, sasniegumiem un ieguvumiem; - Nodrošināt bīstamo atkritumu nodošanas punktus klientiem (baterijas u.c.); - Nodrošināt KSA pasākumus mazpilsētu tirdzniecības vietās (atbildība pret vidi).
Ekonomiskā atbildība	- Par mērķi izvirzīt ne tikai palielināt peļņu, bet arī pārliecināties, ka uzņēmējdarbība pozitīvi atsaucas uz vidi un sabiedrību.
Filantropiskā atbildība	- Sniegt publisku darbību atskaiti un pārskatu, par klientu sniegto filantropisko atbalstu; - Sniegt publisku darbību atskaiti un pārskatu, par uzņēmuma sniegto filantropisko atbalstu; - Piešķirt atlaides (kuponu, punktu, virtuālās naudas u.c.) veidā ziedoto preču iegādei tirdzniecības vietā; - Nodrošināt ziedošanas kastes ar iespēju klientiem nodot apģērbu un citus sadzīves priekšmetus otrreizējai lietošanai; - Nodrošināt KSA pasākumus mazpilsētu tirdzniecības vietās (filantropiskā atbildība).

Pēc pētījuma autore domām iegūtie rezultāti liecina par to, ka atsevišķas KSA darbības spēj veicināt klientu lojalitāti uzņēmumam. KSA ietekme uz klientu lojalitāti ir nepārprotama, jo ir vērojama sakarība starp apmeklētību tajos mazumtirdzniecības uzņēmumos Latvijā, kas skaidri ir definējuši KSA politiku savā uzņēmumā un strādā pie tās izpildes, un tiem uzņēmumiem kuros KSA politika pastāv daļēji vai nav definēta vispār. Veicot pētījumu autore secina, ka korporatīvās sociālās atbildības loma un ietekme uz uzņēmuma darbības rezultātīvajiem rādītājiem ir ļoti liela un ir svarīga teju jebkuram uzņēmumam, kurš strādā visciešākajā saskarsmē ar klientiem un vēlas gan iegūt priekšrocību pār konkurentiem, gan veicināt klientu lojalitāti, gan sniegt piensumu pasaulei un sabiedrībai kopumā.

### Secinājumi

Izpētot KSA aktivitātes mazumtirdzniecības uzņēmumos Latvijā, tiek izstrādāti šādi secinājumi:

- Pētījuma jautājums ir atbildēts – anketēšanas rezultāti norāda, ka respondenti visaugstāk vērtē KSA ētiskās atbildības aktivitātes, bet viszemāk filantropiskās atbildības aspektus, kas ietekmē arī viņu lojalitāti uzņēmumam.
- Balstoties uz sekundāro datu analīzi un mediju monitoringu secināts, ka vairāki no lielākajiem mazumtirdzniecības uzņēmumiem Latvijā nav definējuši KSA politiku un uzņēmējdarbību nebalsta uz KSA vērtībām.
- Balstoties uz anketēšanas rezultātiem secināts, ka KSA aktivitātes spēj veicināt un ietekmēt klientu lojalitāti uzņēmumam. Ir vērojama sakarība starp apmeklētību tajos mazumtirdzniecības uzņēmumos Latvijā, kas skaidri ir definējuši KSA politiku savā uzņēmumā un strādā pie tās izpildes un tiem uzņēmumiem kuros KSA politika nav definēta vispār.
- Balstoties uz anketēšanas rezultātiem secināts, ka respondenti ne vienmēr uzticas tam, ka mazumtirdzniecības uzņēmumi Latvijā veic godprātīgu KSA izpildi.

- Balstoties uz anketēšanas rezultātiem secināts, ka 24% respondentu norāda, ka mazumtirdzniecības uzņēmumiem būtu jāievieš vai jāpilnveido KSA aktivitātes Latvijas mazpilsētās, kas, iespējami, sekmētu klientu lojalitāti.

Balstoties uz secinājumiem tiek izvirzīti šādi priekšlikumi:

- Mazumtirdzniecības uzņēmumu, kas savu darbību balsta uz KSA praksi, vadībai būtu jāizstrādā informatīvi materiāli, lai iepazīstinātu un izglītotu klientus par KSA aktivitāšu nozīmīgumu, lai, iespējami, ieviestu balansu veiktajās KSA darbībās un veicinātu klientu lojalitāti.
- Mazumtirdzniecības uzņēmumu vadībai, kas līdz šim savā uzņēmējdarbībā nav ieviesuši KSA praksi, sadarbībā ar uzņēmuma juridisko departamentu būtu jāiepazīstas ar Apvienoto Nāciju Organizācijas Globālo līgumu, un jāizvērtē iespēja savā uzņēmumā ieviest un īstenot KSA labās pārvaldības principus, kas, iespējami, ietekmētu gan klientu lojalitātes rādītājus, gan pozitīvi atsauktos uz vidi kopumā.
- Mazumtirdzniecības uzņēmumu vadībai ir jāizstrādā publiski pieejami veikto KSA pasākumu aktivitāšu pārskati vai ziņojumi, un, ja tādi tiek sniegti, tiem ir jābūt uzskatāmākiem nekā tie ir līdz šim, ar mērķi informēt sabiedrību par veiktajām KSA darbībām un ieguvumiem, kas ilgtermiņā, iespējami, veicinātu klientu uzticamību un lojalitāti konkrētajam uzņēmumam.
- Mazumtirdzniecības uzņēmumu vadībai un mārketinga departamentam ir jāstiprina KSA aktivitātes mazumtirdzniecības vietās mazpilsētās, rūpējoties par klientu ērtību, veicinot filantropisko atbildību un atbildību pret vidi, kas, iespējami, veicinātu klientu lojalitāti uzņēmumam.

### Izmantotās literatūras un informācijas avotu saraksts

Chandler, D. (2022). *Strategic corporate social responsibility. sustainable value creation*. SAGE Publications.

Forbes (2022). *How corporate social responsibility appeals to your customers*. <https://www.forbes.com/councils/forbesbusinesscouncil/2022/11/04/how-corporate-social-responsibility-appeals-to-your-customers/>

González-Morales, O., Galván-Sánchez, I., & Román-Cervantes, C. (2023). Social responsibility as a source of satisfaction for worker-members in a social economy transport company. *Research in Transportation Business and Management*, 51, 101070.

Harvard Business School (2021a). *Corporate social responsibility statistics*. <https://online.hbs.edu/blog/post/corporate-social-responsibility-statistics>

Harvard Business School (2021b). *What is corporate social responsibility?* <https://online.hbs.edu/blog/post/types-of-corporate-social-responsibility>

Labklājības ministrija (2020). *ANO Globālais līgums un korporatīvā sociālā atbildība*. <https://www.lm.gov.lv/lv/ano-globalais-ligums-un-korporativa-sociala-atbildiba>

Latapí-Agudelo, M.A., Jóhannsdóttir, L., & Davídsdóttir, B. (2019.) A literature review of the history and evolution of corporate social responsibility. *International Journal of Corporate Social Responsibility*, 4, 1.





- Latvijas darba devēju konfederācija (2023). *Korporatīvā sociālā atbildība*. <https://lddk.lv/par-lddk/darbibas-virzieni/korporativa-sociala-atbildiba/>
- Lidl (2023). *Korporatīvā sociālā atbildība*. <https://corporate.lidl.lv/lv/korporativa-atbildiba>
- Lidl (2021). 7. oktobrī “Lidl” atvērs 15 veikalus Latvijā. <https://corporate.lidl.lv/lv/preses-relizes/2021/atversanas-datums>
- Lursoft (2023a). *Firma Madara 89, SIA*. <https://company.lursoft.lv/firma-madara-89/40003115846>
- Lursoft (2023b). *Lidl Latvija, SIA*. <https://company.lursoft.lv/lidl-latvija/40203023760>
- Lursoft (2023c). *MAXIMA Latvija, SIA*. <https://company.lursoft.lv/maxima-latvija/40003520643>
- Lursoft (2023d). *MEGO, SIA*. <https://company.lursoft.lv/mego/40003461212>
- Lursoft (2023e). *RIMI Latvija, SIA*. <https://www.lursoft.lv/gada-parskati/rimi-latvia/40003053029>
- Maxima (2023). *Ilgspēja*. <https://www.maxima.lv/ilgtspeja>
- Mego (2023). *Mego - tavs tuvākais veikals*. <https://mego.lv/par-mums>
- Nechaev, I., & Hain, D. S. (2023). Social impacts reflected in CSR reports: Method of extraction and link to firms innovation capacity. *Journal of Cleaner Production*, 429, 139256.
- Nguyen, N., Priporas, C.V., McPherson, M., & Manyiwa, S. (2023). CSR-related consumer scepticism: A review of the literature and future research directions. *Journal of Business Research*, 169, 114294.
- Rimi (2023). *Rimi korporatīvās atbildības pārskats 2022*. <https://www.rimi.lv/rimi-korporativas-atbildibas-parskats-2022>
- ScopusS (2024). *Scopus*. <https://www.scopus.com/search/form.uri?display=basic&zone=header&origin=#basic>
- Top (2023). *Par uzņēmumu*. <https://www.toppartika.lv/par-mums/>
- Vevere, V., Svirina, A. (2020). *Business ethics and corporate social responsibility*. Ekonomikas un kultūras augstskola



## Zita Draveniece. DARBINIEKU APMIERINĀTĪBU IETEKMĒJOŠIE FAKTORI PAKU SŪTĪJUMU NOZARĒ LATVIJĀ

*Ekonomikas un kultūras augstskola  
Maģistra studiju programma "Biznesa vadība"  
E-pasts: zita.draveniece@inbox.lv  
Zinātniskais vadītājs: Dr.phil., profesore Velga Vēvere*

### Anotācija

**Pētījuma aktualitāte:** Zinātniskā raksta tēma: "Darbinieku apmierinātību ietekmējošie faktori paku sūtījumu nozarē Latvijā" ir ļoti aktuāla. Darbinieku apmierinātība nosaka to snieguma rezultātu un darba ražīgumu, kam ir nozīmīga ietekme uz uzņēmējdarbības rezultātiem, uzņēmumu konkurētspēju pasaules tirgū un peļņu, kas ietekmē tautsaimniecības attīstību kopumā. (Zand & Chang, 2020). Līdz šim nav veikti specifiski pētījumi, lai noskaidrotu galvenos faktoros, kas ietekmē darbinieku apmierinātību paku sūtījumu nozarē Latvijā. Darbinieku apmierinātību ietekmējošo faktoru paku sūtījumu nozarē Latvijā identificēšana sniegtu iespēju nozares uzņēmumiem veikt mērķtiecīgas darbības, lai paaugstinātu darbinieku apmierinātību, tā saglabājot darbiniekus, mazinot darbinieku rotāciju un kopumā nodrošinot nepieciešamā darbaspēka apjomu.

**Pētījuma mērķis:** Apzināt darbinieku apmierinātību ietekmējošos faktoros paku sūtījumu nozarē Latvijā.

**Pētījuma metodes:** Pētījuma veikšanai izmantotas gan kvantitatīva metode (aptauja, ar mērķi izzināt darbinieku paku sūtījumu nozarē Latvijā viedokli par to apmierinātību ietekmējošiem faktoriem), gan kvalitatīvas pētījumu metode (daļēji strukturētas ekspertu intervijas, ar mērķi novērtēt aptaujā ievāktu datu praktisko pielietojumu).

**Sasniegtie rezultāti:** Paku sūtījumu nozarē Latvijā pēc darbinieku vērtējuma nozīmīgākā loma darbinieku apmierinātības veidošanā ir atalgojuma faktoru kopai, kam seko personīgās attīstības iespēju faktoru kopa, darba apstākļu faktoru kopa, komunikācijas faktoru kopa, ar kolēģiem saistīti faktoru kopa un uzraudzības faktoru kopa.

*Atslēgas vārdi: darbinieku apmierinātība; darbinieku apmierinātību ietekmējošie faktori; paku sūtījumu nozare.*

### Ievads

Lai arī transporta un uzglabāšanas nozare Latvijā ir viena no piecām lielākajām nozarēm pēc nodarbināto skaita, tajā ietilpstošā paku sūtījumu nozare saskaras ar nozīmīgiem izaicinājumiem, lai nodrošinātu nepieciešamā darbaspēka apjomu. Ņemot vērā nozares ietvaros nodrošināto pakalpojumu apjoma pieauguma tendenci, neraugoties uz tehnoloģisko un automatizācijas risinājumu attīstību, prognozējams, ka jau tuvākajā nākotnē paku sūtījumu nozare saskarsies ar aizvien lielākiem izaicinājumiem attiecībā uz nepieciešamā darbaspēka apjoma nodrošināšanu.

Darbaspēka trūkums paku sūtījumu nozarē rada ievērojamus izaicinājumus uzņēmumiem, ietekmējot to spēju apmierināt pieprasījumu un saglabāt konkurētspēju. Tomēr ir vairākas stratēģijas, kuras uzņēmumi var izmantot, lai risinātu šīs problēmas. Viena no galvenajām stratēģijām ir ieguldīt darbinieku apmācību un kvalifikācijas paaugstināšanas programmās. Uzlabojot sava darbaspēka prasmes, uzņēmumi var uzlabot produktivitāti, pielāgoties izmaiņām tehnoloģijā un automatizācijā, paaugstināt darbinieku apmierinātību un saglabāt darbiniekus ilgāku laiku, un tā saglabāt konkurētspēju un apmierināt augošās nozares prasības.

Lai nodrošinātu gan paku sūtījumu nozarē kopumā, gan katra komersanta, kurš paku sūtījumu nozarē darbojas darbinieku skaita pietiekamību, svarīgi nodrošināt nozarē strādājošo darbinieku apmierinātību.

Pētījuma mērķis bija apzināt darbinieku apmierinātību ietekmējošos faktorus paku sūtījumu nozarē Latvijā. Pētījumā tika izvirzīti šādi pētījuma uzdevumi:

- Apkopot un teorētiski analizēt zinātnisko literatūru par darbinieku apmierinātību ietekmējošiem faktoriem;
- Veikt paku sūtīju nozares Latvijā izpēti;
- Veikt pētījumu par darbinieku apmierinātību ietekmējošiem faktoriem paku sūtījumu nozarē Latvijā.
- Pētījuma jautājums: Kādi ir darbinieku apmierinātību ietekmējošie faktori paku sūtījumu nozarē Latvijā?

Datu vākšanas metodes bija šādas:

- Kvantitatīva pētījumu metode, proti, aptauja, ar mērķi izzināt darbinieku paku sūtījumu nozarē Latvijā viedokli par to apmierinātību ietekmējošiem faktoriem.

Datu apstrādes metode bija šāda:

- Aptaujā ievākto datu analīze Microsoft Excel, vidējais aritmētiskais, moda, mediāna ;
- Aptaujā ievākto datu grafiskā analīze ;
- Aptaujā ievākto datu analīze SPSS, Kronbaha alfa, darbinieku apmierinātības un augsti novērtēto apmierinātību ietekmējošo faktoru korelācija.

Pētījuma rezultāti: Paku sūtījumu nozarē Latvijā pēc darbinieku vērtējuma nozīmīgākā loma darbinieku apmierinātības veidošanā ir atalgojuma faktoru kopai, kam seko personīgās attīstības iespēju faktoru kopa, darba apstākļu faktoru kopa, komunikācijas faktoru kopa, ar kolēģiem saistīti faktoru kopa un uzraudzības faktoru kopa.

### **Analītiskais apskats**

Vispārpieņemta darbinieku apmierinātības definīcija nepastāv, tomēr literatūrā ir daudz apmierinātības ar darbu definīciju, kam par iemeslu ir tas, ka apmierinātība ar darbu dažādiem cilvēkiem nozīmē dažādas lietas, jo darbiniekus ietekmē dažādi faktori, tostarp personiskās īpašības, vajadzības, vērtības, jūtas un cerības. Tāpat tas atšķiras dažādās organizācijās, jo apmierinātību ar darbu ietekmējošie faktori, piemēram, darba vide, darba raksturojums, darbinieku iespējas un darba vide atšķiras atkarībā no organizācijas (Harputlu, 2014).

Apmierinātība ar darbu tiek definēta kā cilvēka pašsajūta vai garastāvoklis saistībā ar darbu (Chughati & Perveen, 2013) kā arī darbinieka pozitīva attieksme pret uzņēmumu, kolēģiem un, visbeidzot, darbu (Syniewska, 2013). Organizācijai izpildot darbinieku cerības attiecībā pret darbu, darbinieks izjūt pozitīvas emocijas, un šīs pozitīvās emocijas liecina par apmierinātību ar darbu (Green, 2000).

Apmierinātības ar darbu teoriju aizsākums ir Frederika V. Teilora ideja par “zinātnisko vadību” vai “teilorismu” 1911. gadā. Frederiks V. Teilors, Frenks Gilbrets un Henrijs L. Gants ierosināja algu stimulēšanas modeļus, lai motivētu cilvēkus darbā. Saskaņā ar šo ideju cilvēkus varētu motivēt tikai

nauda (Luthans, 1995). Literatūrā ir vairākas atšķirīgas teorijas, kas mēģina izskaidrot apmierinātību ar darbu, no kurām ievērojamākās ir sadalītas divās kategorijās - satura teorijas un procesu teorijas.

Nozīmīgākās satura teorijas ir:

- Maslova vajadzību hierarhijas teorija;
- Aldefera - ERG;
- Hercberga divu faktoru teorija;
- Maklelanda vajadzību teorija.

Nozīmīgākās procesa teorijas ir:

- Gaidu teorija;
- Līdztiesības teorija;
- Neatbilstības teorija;
- Darba raksturojuma teorija;
- Mērķu noteikšanas teorija, u.c. (Zand & Chang, 2020).

Izstrādājot darbinieku apmierinātības teorijas, to ietvaros pētnieki definējuši dažādus faktorus, kas ietekmē darbinieku apmierinātību. Darbinieku apmierinātību ietekmējošie faktori ir iedalīti divās galvenajās grupās - vides faktori un personiskie faktori. Personiskie faktori ietver demogrāfiskos mainīgos, kas ir dzimumu, vecumu, izglītības līmeni, darba stāžu. Vides faktori ietver darba apstākļus, personīgās attīstības iespējām, atalgojumu, uzraudzību, kolēģus, un komunikāciju (Spector, 1997). Darbinieku apmierinātību nosaka darbinieka raksturlielumi, kas veido darbinieka paša uztveri un virkne ārēji apstākļi, un, ņemot vērā šos darbinieka raksturlielumus, darbinieku apmierinātību ietekmējošiem faktoriem var būt dažāda nozīmē un ietekme un darbinieku apmierinātību.

Termins CEP ir saīsinājums no “kurjerpasta, eksprespasta un paku pakalpojumi” (Courier, Express and Parcel Services, Eng.). Tas attiecas uz pasta un loģistikas uzņēmumiem, kas galvenokārt pārvadā sūtījumus ar salīdzinoši mazu svaru un tilpumu, piemēram, vēstules, sīkpakas, dokumentus vai sīkas sūtījumus, turpmāk darbā – paku sūtījumu nozare (Skupell & Wodnicka, 2023). Latvijā paku sūtījumu nozare ir ietverta Pasta nozarē un to regulē Sabiedrisko Pakalpojumu Regulēšana Komisija (SPRK). 2023. gadā Latvija pasta nozarē kopējie ieņēmumi bez Pievienotās Vērtības nodokļa veidojuši 173.7 miljonus eiro (sk. 1.att.).

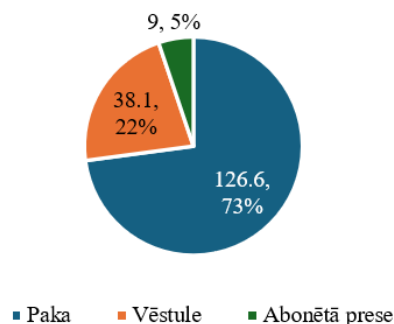

**1.att.** Ieņēmumi pasta nozarē pa sūtījumu veidiem 2023. gadā Latvijā milj. eiro (Avots: autores veidots pēc SPRK, 2024)

Pārrobežu nosūtīto vēstuļu skaits periodā no 2019. līdz 2023. gadam samazinājies par 50%, savukārt pārrobežu nosūtīto paku skaits tajā pašā periodā pieaudzis par vairāk kā 100%.

Pasta nozarē iekšzemē nosūtītās abonētās preses skaitam ik gadu ir tendence samazināties, no 2019. līdz 2023. gadam samazinājums veido 30%, tāpat tendence samazināties ir arī iekšzemē nosūtīto vēstuļu skaitam, no 2019. līdz 2023. gadam samazinājums veido 49%. Savukārt nosūtīto paku skaits no 2019. līdz 2021. gadam palielinājies vairāk kā par 100%, 2022. gadā saglabājies teju nemainīgs un 2023. nedaudz samazinājies. Secināms, ka apjomam paku sūtījumu nozarē Latvijā tāpat kā pasaulē ir tendence palielināties. Autore apkopojusi datus par pasta sūtījumu nozarē Latvijā komersantiem, kuri 2023. gadā izpildījuši lielāko sūtījumu skaitu (sk. 2.att.).

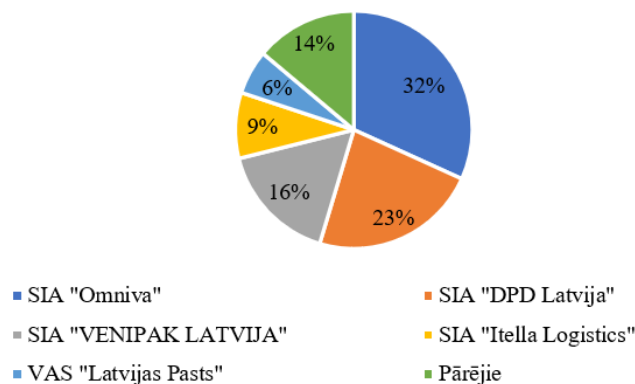

**2. att.** Sūtījumu skaits pa komersantiem 2023. gadā Latvijā (Avots: autores veidots pēc SPRK, 2024)

32% no visiem nosūtītajiem sūtījumiem izpildījusi SIA “Omniva”, kam seko SIA “DPD Latvija”, kas izpildījusi 23% no visiem sūtījumiem, ar 16% seko SIA “VENIPAK LATVIJA”, 9% SIA “Itella Logistics” un 6% VAS “Latvijas pasts”. No kā secināms, 5 uzskaitītāji, jeb 8% komersanti, izpilda 86% no visiem sūtījumiem pasta nozarē Latvijā un 55, jeb 92% komersanti izpilda vien 14% no visiem sūtījumiem pasta nozarē Latvijā.

Pēc Centrālās Statistikas Pārvaldes (CSP) datiem, pasta nozarē nodarbināto skaits ir ietverts transporta un uzglabāšanas nozares nodarbināto skaitā, kas ir viena no piecām lielākajām nozarēm Latvijā pēc nodarbināto skaita. Nozarē nodarbināto skaits no 2019. līdz 2022. gadam ir samazinājies, savukārt 2023. gadā atkal palielinājies līdz 2019. gada līmenim, turklāt palielinājumu veidojis tieši nozarē strādājošo vīriešu skaita palielinājums. 2023. gadā no visiem transporta un uzglabāšanas nozarē strādājošajiem 30% bijušas sievietes un 70% vīrieši.

Deloitte ziņojumā par paku sūtījumu nozares tendencēm, uzskaitīti būtiskākie izaicinājumi, ar kuriem saskaras paku sūtījumu nozare, ikviens no uzskaitītajiem izaicinājumiem ir pieaugošs darbaspēka trūkums.

Paku sūtījumu nozarē darbaspēka trūkums ir būtisks izaicinājums, ierobežotā darbinieku pieejamība apgrūtina pieprasījuma apmierināšanu, kā rezultātā rodas kavēšanās un klienti ir neapmierināti. Darbinieku trūkums var palielināt darbaspēka izmaksas, jo uzņēmumi piedāvā labākas algas un pabalstus, lai noturētu un piesaistītu darbiniekus. Šie faktori var negatīvi ietekmēt nozares uzņēmumu peļņu un konkurētspēju.

Paku sūtījumu nozare, visticamāk, turpinās attīstīties arī turpmākajos gados, ko veicinās e -komercijas pieaugums. Iespējams, ka pieaugumu pavadīs arī izmaiņas tehnoloģijās un automatizācijā, kas var ietekmēt darbaspēka pieprasījumu. Uzņēmumiem ir svarīgi saglabāt elastību un pielāgoties šīm pārmaiņām, ieguldot apmācībās un kvalifikācijas paaugstināšanas programmās, lai viņu darbinieki saglabātu konkurētspēju un to apmierinātība ar darbu būtu augsta, tā samazinot darbaspēka rotāciju un nodrošinot darbaspēka pietiekamību (Maniam et al., 2022).

### Pētījuma metodoloģija

Pētījuma veikšanai darba autore izstrādājusi strukturētu aptaujas anketu ar slēgtiem pantiem, kura sastāv no 3 daļām. Aptaujas anketas pirmā daļa sastāv no 4 pantiem, kuri izzina respondentus, to dzimumu, vecumu, izglītības līmeni un darba stāžu uzņēmumā. Aptaujas anketas otrā daļa sastāv no 7 pantiem, kuri veidoti katrā no vides faktoru kopām, kas veido darbinieku apmierinātību, darba apstākļi, personīgās attīstības iespējas, atalgojums, uzraudzība, kolēģi un komunikācija un katru no visas faktoru kopas kopā, un aicina darbiniekus sarindot faktorus pēc to nozīmīguma no 1 līdz 5. Anketas trešā daļa sastāv no 31 panta, kur darbinieki aicināti novērtēt savu apmierinātību visās faktoru kopās ar katru no identificētajiem faktoriem.

Trešajā daļā atbildes uz jautājumiem veidotas pēc Likerta skalas, noteiktas vērtības no 1 - pilnībā nepiekrītu, līdz 4 - pilnībā piekrītu, kas sniedz iespēju aptaujā neievākt neitrālus vērtējumus. Lai iegūtu iespējami pilnīgus datus par darbinieku apmierinātību, pamatojoties uz veikto paku sūtījumu nozares Latvijā izpēti, par pētījuma izlasi noteikti 5 lielāko uzņēmumu, kas kopumā nodrošina 86% no pakalpojumu izpildes darbinieki, SIA “Omniva”, SIA “DPD Latvija”, SIA “VENIPAK LATVIJA”, SIA “Itella Logistics” un VAS “Latvijas Pasts” darbinieki (sk. 3.att.).

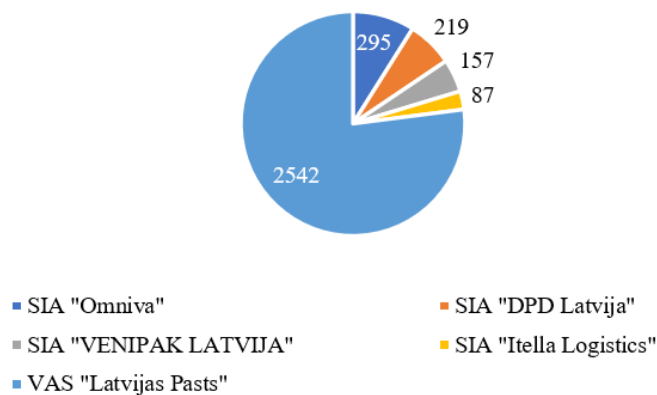

**3. att.** Pētījuma izlase (Avots: autores veidots pēc Firmas.lv, 2024)

3.attēlā redzams, ka VAS “Latvijas pasts” darbinieku skaits pārsniedz citu pētījuma izlasē iekļauto uzņēmumu darbinieku skaitu pat 25 reizes, tāpēc, lai nodrošinātu, ka pētījuma rezultāti sniedz ieskatu par visu pētījuma izlasē ietverto uzņēmumu darbinieku apmierinātību ietekmējošiem faktoriem un izvairoties no augsta VAS “Latvijas pasts” respondentu skaita īpatsvara, par pētījuma izlasi noteikti 87 (zemākais darbinieku skaits pētījuma izlasē iekļautajos uzņēmumos) darbinieki no katra pētījuma izlasē iekļautā uzņēmuma, kopumā 435 darbinieki.

Aptaujas anketa sagatavota elektroniski un izvietota datu vākšanas un uzglabāšanas vietnē Google aptaujas, kas nodrošina ievāktos datus apkoptā veidā. Aicinājums piedalīties aptaujā nosūtīts e-pastā 5 lielāko uzņēmumu paku sūtījumu nozarē kontaktpersonām, kas aicinājumu piedalīties aptaujā nosūtījušas visiem uzņēmumu darbiniekiem. Aptauja norisinājusies 3 nedēļas no 2024. gada 4. marta līdz 24. martam, pētījumā piedalījušies visi, 326 paku sūtījumu nozares Latvijā darbinieki, jeb 75% no pētījuma izlases, kas uzskatāms par izcilu rādītāju. Aptaujā ievāktie dati analizēti veicot grafisko analīzi un SPSS, nosakot Kronbaha alfa, un darbinieku apmierinātības un augsti novērtēto apmierinātību ietekmējošo faktoru korelāciju.

### Pētījuma rezultāti

Pamatojoties uz aptaujā ievāktajiem datiem, autore veikusi visu darbinieku apmierinātību ietekmējošo faktoru kopu nozīmības grafisko analīzi (sk. 4.att.).

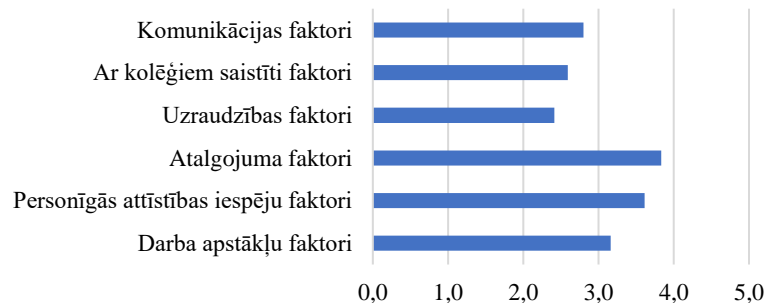

**4. att.** Visu faktoru kopu nozīmība darbinieku apmierinātības veidošanā paku sūtījumu nozarē Latvijā (Avots: autores veidots pēc aptaujas datiem)

4.attēlā uzskatāmi atainots, ka darbinieku apmierinātības veidošanā pēc darbinieku vērtējuma nozīmīgākā ietekme ir atalgojuma faktoriem, kam seko personīgās attīstības iespēju faktori un darba apstākļu faktori. Salīdzinoši ar zemāku nozīmību novērtēti komunikācijas faktori, ar kolēģiem saistīti faktori un uzraudzības faktori.

Darba autore veikusi vidējā aritmētiskā aprēķinu, tā noskaidrojot darbinieku apmierinātību ar katru no darbinieku apmierinātību ietekmējošām faktoru kopām (sk. 5.att.).

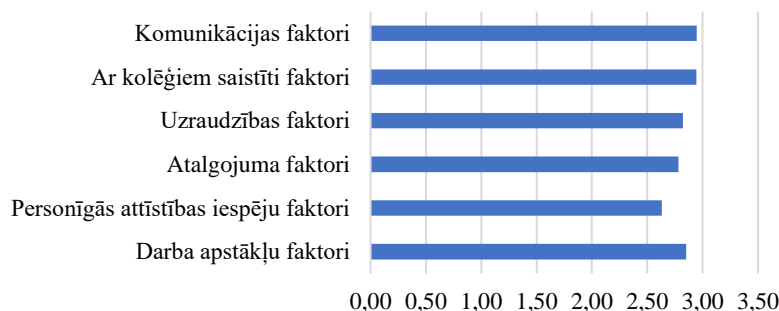

**5. att.** Darbinieku apmierinātība ar apmierinātību ietekmējošiem faktoriem paku sūtījumu nozarē Latvijā (Avots: autores veidots pēc aptaujas datiem)

5.attēlā atainots, ka kopumā darbinieki ir gandrīz vienlīdz apmierināti ar visām apmierinātību ietekmējošo faktoru kopām, tomēr uzskatāmi atainots, ka apmierinātība ir zemāka ar personīgās attīstības iespēju faktoriem.

Veicot Kolmogorova – Smirnova testu katrā aptaujas anketas skalā atsevišķi, novērot, ka ir atbilstība normālsadalījumam kā arī ļoti būtiskas un maksimāli būtiskas atšķirības no normālsadalījuma.

Vairākās aptaujas anketas skalās datu sadalījums neuzrāda atbilstību normālsadalījumam, tāpēc turpmāk pētījuma veikšanai izmantotas neparametriskās statistiskās analīzes metodes. Veikta Pīrsona pāru korelācijas analīze un noteikts vai pastāv būtiska sakarība starp pētījuma gaitā identificētajiem darbinieku apmierinātību ietekmējošiem faktoriem un darbinieku apmierinātību (sk. 1. tabulu).

**1.tabula.** Pīrsona pāru korelācijas analīze (Avots: autores aprēķini pēc aptaujā ievāktajiem datiem)

	Kopējā apmierinātība			Korelācijas veids	Statistiskā nozīmība
	Pīrsona korelācijas koeficients (r)	p vērtība	N		
Darba apstākļu faktori	0,404	0,008	326	Starp pazīmēm ir viduvēja pozitīva korelācija	statistiski nozīmīga
Personīgās attīstības iespēju faktori	0,403	0,008	326	Starp pazīmēm ir viduvēja pozitīva korelācija	statistiski nozīmīga
Atalgojuma faktori	0,429	0,005	326	Starp pazīmēm ir viduvēja pozitīva korelācija	statistiski nozīmīga
Uzraudzības faktori	0,355	0,021	326	Starp pazīmēm ir viduvēja pozitīva korelācija	statistiski nozīmīga
Ar kolēģiem saistīti faktori	0,355	0,021	326	Starp pazīmēm ir viduvēja pozitīva korelācija	statistiski nozīmīga
Komunikācijas faktori	0,365	0,017	326	Starp pazīmēm ir viduvēja pozitīva korelācija	statistiski nozīmīga

Analizējot sakarības starp kopējo darbinieku apmierinātību un apmierinātību ar dažādām apmierinātību ietekmējošām faktoru kopām, darba apstākļu faktori, personīgās attīstības iespēju faktori, atalgojuma faktori, uzraudzības faktori, ar kolēģiem saistīti faktori un komunikācijas faktori, konstatēta pozitīva, vidēji cieša, statistiski nozīmīga sakarība starp rādītājiem, kas liecina, ka atšķirīgi rādītāji daļēji pārklājas un ir savstarpēji saistīti. Analizējot datus par sakarībām, noskaidrots, ka matemātiski statistiski visciešākā sakarība ir starp darbinieku apmierinātību un atalgojuma faktoriem,  $r=0,429$ , kam seko darba apstākļu faktori un personīgās attīstības iespēju faktori.

### Secinājumi

Pētījuma mērķis: Apzināt darbinieku apmierinātību ietekmējošos faktoros paku sūtījumu nozarē Latvijā, ir sasniegts. Pētījuma uzdevumi ir izpildīti. Pētījuma jautājums: “Kādi ir darbinieku apmierinātību



ietekmējošie faktori paku sūtījumu nozarē Latvijā?” ir atbildēts.

Paku sūtījumu nozarē Latvijā pēc darbinieku vērtējuma nozīmīgākā loma darbinieku apmierinātības veidošanā ir atalgojuma faktoru kopai, kam seko personīgās attīstības iespēju faktoru kopa un darba apstākļu faktoru kopa. Salīdzinoši ar zemāku nozīmību novērtēta komunikācijas faktoru kopa, ar kolēģiem saistīti faktoru kopa un uzraudzības faktoru kopa.

Darbinieki paku sūtījumu nozarē Latvijā kopumā ar darbu ir apmierināti un ir gandrīz vienlīdz apmierināti ar visām darbinieku apmierinātību ietekmējošām faktoru kopām.

Korelācijas koeficienta aprēķina rezultāti sakrīt ar aptaujas otrajā daļā ievāktajiem datiem un liecina, ka darbinieku apmierinātību visnozīmīgāk ietekmējošās faktoru kopas ir atalgojuma faktori, personīgās attīstības iespēju faktori un darba apstākļu faktori.

### Izmantotās literatūras un informācijas avotu saraksts

Chughati, F. D., & Perveen, U. (2013). A study of teachers workload and job satisfaction in public and private schools at secondary level in Lahore city Pakistan. *Asian Journal of Social Sciences and Humanities*, 2(1), 202-214.

Firmas.lv (2024). Firmas datubāze. <https://www.firmas.lv/>

Harputlu, S. (2014). Job satisfaction and its relation with perceived workload: An application in a research institution. Middle East Technical University.

Luthans, F. (1995). *Organizational behaviour*. McGraw-Hill.

Maniam, S., Rusuli, M. S. C., Yaziz, M. F. A., Hussin, K. C., & Nasir, W. M. N. W. M. (2022). The impact of autonomous vehicles in parcel industry in Kedah. *Research in Management of Technology and Business*. <http://hdl.handle.net/123456789/3528>

Scupell, D., & Wodnicka, M. (2023). Reverse logistics of e-commerce as a challenge for the CEP industry. *Scientific Papers of Silesian University of Technology, Organization and Management*, 170.

Sypniewska, B. A. (2013). Evaluation of factors influencing job satisfaction. *Vizja Press & IT*, 57-71. [https://www.researchgate.net/publication/285109808\\_Evaluation\\_of\\_Factors\\_Influencing\\_Job\\_Satisfaction](https://www.researchgate.net/publication/285109808_Evaluation_of_Factors_Influencing_Job_Satisfaction)

Spector, P. E. (1997). *Job satisfaction: Application, assessment, causes, and consequences*. Sage Publications.

Sabiedrisko pakalpojumu regulēšanas komisija (SPRK) (2024). *Pasta nozares darbības rādītāji*. <https://www.sprk.gov.lv/content/nozares-raditaji-10>

Zand, Z. M., & Chang Y. (2020). Determinants of public employee job satisfaction in Myanmar: Focus on Herzberg's two factor theory. *Public Organization Review*, 21, 157-175. <https://doi.org/10.1007/s11115-020-00481-6>



## **Nauris Sedlers. INTEGRĒTĀS VADĪBAS SISTĒMAS PAPLAŠINĀŠANAS IESPĒJAS NODROŠINOT ATBILSTĪBU JAUNAM STANDARTAM UZŅĒMUMĀ “INTERLUX”**

*Ekonomikas un kultūras augstskola  
Maģistra studiju programma “Biznesa vadība”  
E-pasts: nauris.sedlers@gmail.com  
Zinātniskais vadītājs: Mg. oec. Jānis Pildavs*

### **Anotācija**

**Pētījuma aktualitāte:** Integrētās vadības sistēmas (IVS) ir kļuvušas par būtisku sastāvdaļu mūsdienīgu uzņēmumu darbībā, palīdzot uzlabot to darbības rādītājus un sasniegt augstāku darba efektivitāti. Šajā kontekstā pētījums fokusējas uz uzņēmuma esošās IVS paplašināšanas iespējām, ieviešot atbilstību jaunam standartam ISO 13485, lai saglabātu un uzlabotu uzņēmuma konkurētspēju dinamiskas konkurences apstākļos.

**Pētījuma mērķis:** Pētījuma galvenais mērķis ir identificēt un izvērtēt iespējas integrēt jaunu ISO 13485 standartu uzņēmuma esošajā integrētajā vadības sistēmā, saglabājot tās atbilstību uzņēmuma vīzijai, mērķiem un starptautiskiem normatīviem. Tādējādi pētījums sniegs ieteikumus uzņēmumam, kā sekmīgi paplašināt IVS, integrējot tajā ISO 13485 standarta prasības un elementus.

**Pētījuma metodes:** Pētījuma metožu pamatā ir literatūras pārskats par integrēto kvalitātes vadības sistēmu, ISO 9001 un ISO 13485 standartiem un to savstarpējo mijiedarbību. Papildus tam, tiks veikta uzņēmuma vadības sistēmas dokumentu analīze un padziļinātas intervijas ar uzņēmuma vadību un kvalitātes vadības speciālistu, lai ar transkripcijas palīdzību iegūtu praktisku izpratni par pašreizējo IVS, tās ieguvumiem, problēmām un iespējamajām paplašināšanas iespējām. Pētījuma rezultātu apkopošanai tiks izmantota grafiskā analīze.

**Sasniegtie rezultāti:** Pētījuma gaitā tiks identificētas un analizētas iespējas integrēt ISO 13485 standartu esošajā IVS, piedāvāti praktiski ieteikumi uzņēmumam, kā sasniegt maksimālo labumu no šādas paplašināšanas un tiks izvērtēta šīs integrācijas ietekme uz uzņēmuma darbību. Tādējādi pētījums palīdzēs uzņēmumam pielāgoties mainīgajiem uzņēmējdarbības vides apstākļiem un stiprināt tā konkurētspēju tirgū, nodrošinot augstāku darbības efektivitāti un piedāvāto produktu kvalitāti, tādējādi uzlabojot uzņēmuma ilgspēju un sniedzot labumu vispārējai sabiedrības veselībai un vides kvalitātei.

*Atslēgas vārdi: kvalitāte; sistēma; vadība; integrācija; konkurētspēja.*

### **Ievads**

Mūsdienīgos uzņēmumos par būtisku to darbības sastāvdaļu ir kļuvušas Integrētās vadības sistēmas (IVS), īpaši joprojām augošajā medicīnas iekārtu ražošanas, izplatīšanas un ar to saistīto pakalpojumu sniegšanas sfērā, palīdzot uzlabot to darbības rādītājus un sasniegt augstāku darba efektivitāti. Globālie tirgi liecina gan par strauju konkurences pieaugumu, gan par pieaugošām regulatīvajām prasībām šajā sektorā. Piemēram, “Fortune Business Insights” savā pētījumā, globālo medicīnas ierīču tirgu 2023. gadā ir novērtējis 536.12 miljardu ASV dolāru apmērā, paredzot tam 5,9 % ikgadējo izaugsmi, 2030. gadā tirgus apmēram sasniedzot 799.67 miljardus ASV dolāru (1. att.). To veicinās pieaugošie

attīstīto valstu veselības aprūpes sistēmu tēriņi un jauni sasniegumu medicīnisko tehnoloģiju jomā (Fortune Business Insights, 2024) (sk. 1. att.). Līdzīgu izaugsmi nozarei paredz arī jaunākais “Market Data Forecast” pētījums, uzsverot nozīmīgo COVID-19 ietekmi uz industriju, sevišķi mākslīgās elpināšanas un telemedicīnas jomās (Market Data Forecast, 2024).

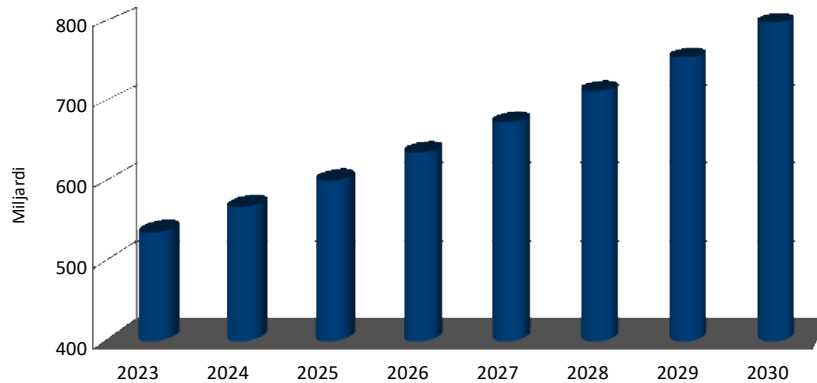

**1.attēls.** Globālā medicīnas tehnoloģiju tirgus izaugsmes prognoze (Avots: autora veidots pēc Fortune Business Insights, 2024)

Šādos dinamiskā vidē strādājošu medicīnas tehnoloģiju uzņēmumos standarta ISO 13485 “Medicīniskās ierīces. Kvalitātes pārvaldības sistēmas. Reglamentējošās prasības” ieviešana, paplašinot esošās IVS, var uzlabot darba kvalitāti, nodrošinot, ka viņu produkti un pakalpojumi atbilst visaugstākajiem kvalitātes un drošības prasībām.

Turklāt, pieaugošā uzmanība un rūpes veselības aprūpes nozarē par produktu drošību, efektivitāti un pacientu labklājību prasa, lai uzņēmumi, kas darbojas šajā jomā, demonstrētu pilnīgu atbilstību standartiem un regulatīvajiem noteikumiem. Tādējādi pētījums par IVS paplašināšanas iespējām, ieviešot jauno ISO 13485 standartu, ir ļoti aktuāls un nozīmīgs, nodrošinot, ka uzņēmumi spēj saglabāt un uzlabot savu konkurētspēju dinamiskajā un prasīgajā medicīnas nozares vidē.

Galvenais pētījuma mērķis ir identificēt un izvērtēt iespējas integrēt jaunu ISO 13485 standartu (LVS EN ISO 13485:2016, 19.05.2016) uzņēmuma "Interlux" esošajā integrētajā vadības sistēmā. Pētījuma uzdevumi ietver:

- Literatūras apskats par ISO 9001 un ISO 13485 standartiem un to savstarpējo mijiedarbību;
- Analizēt uzņēmuma vadības sistēmas dokumentus un identificēt nepieciešamās izmaiņas ISO 13485 standarta ieviešanai;
- Veikt padziļinātas intervijas ar uzņēmuma vadību un kvalitātes vadības speciālistiem, lai izprastu esošās IVS specifiku un papildināšanas ieviestos ieguvumus un izaicinājumus;
- Sagatavot ieteikumus ISO 13485 integrācijai, pamatojoties uz iegūtajiem datiem.

Pētījuma izvirzītā hipotēze ir šāda: integrējot ISO 13485 standartu "Interlux" uzņēmuma vadības sistēmā, tiks uzlabota produktu atbilstība regulatīvajām prasībām un paaugstināta to drošība un efektivitāte, kas veicinās uzņēmuma konkurētspējas un tirgus pozīcijas uzlabošanu.

Pētījumā tiek izmantotas vairākas datu ieguves un apstrādes metodes:

- Literatūras pārskats, lai izprastu standartu teorētisko pamatojumu un ietekmi uz integrēto vadības sistēmu izveides praksēm;
- Dokumentu analīze, lai saprastu uzņēmuma esošās sistēmas konfigurāciju un nepieciešamās modifikācijas;
- Padziļinātās intervijas, izmantojot transkripciju analīzi, lai gūtu dziļāku izpratni par vadības un darbinieku skatījumu uz uzņēmuma IVS un tās attīstības perspektīvām;
- Grafiskā analīze datu un rezultātu vizualizācijai un interpretācijai.

Pētījuma rezultātā tika sagatavoti praktiski ieteikumi ISO 13485 efektīvai integrācijai "Interlux" vadības sistēmā, tostarp vispārējs plāns nepieciešamajām izmaiņām dokumentācijā un procesos. Tika izvērtēta šīs integrācijas potenciālā ietekme uz uzņēmuma konkurētspēju un spēju atbilst augstākiem drošības un kvalitātes standartiem, nodrošinot uzņēmuma ilgtspējīgu attīstību un labāku atbilstību tirgus un regulatīvajām prasībām.

### Analītiskais apskats

ISO 13485 ietveršana integrētajās vadības sistēmās (IVS) medicīnas ierīču nozarē kļūst arvien svarīgāka un nozīmīgāka, jo gan pasaulē, gan Eiropas Savienībā pieaug regulatīvās un tirgus prasības pēc kvalitātes un drošības. Šī standarta integrācija ir svarīga arī kontekstā ar Eiropas Savienības jaunajām regulām par medicīnas ierīcēm (MD) un in vitro diagnostikas medicīnas ierīcēm (IVD), kas paredz detalizētākas prasības kvalitātes vadības sistēmām un produkta dzīves cikla pārvaldībai. Eiropas Savienības regula par medicīnas ierīcēm (Eiropas parlamenta un padomes regula (ES) 2017/745, 05.04.2017) un regula par in vitro diagnostikas medicīnas ierīcēm (Eiropas parlamenta un padomes regula (ES) 2017/746, 05.04.2017) ietver pastiprinātas prasības attiecībā uz produkta drošību, efektivitāti un kvalitātes pārvaldību. Šīs regulas prasa, lai medicīnas ierīču ražotāji ieviestu sistemātiskus riska vadības pasākumus visā produkta dzīves ciklā, kas ir atbilstīgi arī ISO 13485 standarta prasībām par riska pārvaldību (Davar et al., 2024). Lai šis standarts ir harmonizēts ar aktuālo likumdošanu, tā prasības pilnībā nenosedz visas aktuālās atbilstošo regulu prasības un pilnai atbilstībai uzņēmumiem savas IVS ir nepieciešams papildināt ar papildus procedūrām (Brkic, 2023), atbilstību kurām uzņēmumiem nāksies apliecināt ar papildus speciālām sertifikācijām. ISO 13485 sertificētiem uzņēmumiem šajā aspektā būs priekšrocības, tiem būs jau izstrādāts IVS ietvars un šo papildus procedūru ieviešana pilnai atbilstībai likumdošanai būs daudz vienkāršāka un ātrāka (Kheir et al., 2021).

Turklāt, gaidāmās izmaiņas ASV FDA kvalitātes vadības sistēmu regulējumā (QMSR, 2024), kas stājas spēkā 2026. gadā, prasa, lai uzņēmumi saskaņotu savas kvalitātes sistēmas ar ISO 13485 standarta plašākajām un elastīgākajām prasībām (QMSR, 2024). Tomēr FDA arī atzīst, ka ISO 13485 standarts pašlaik neatbilst visām FDA izvirzītajām specifiskajām prasībām, piemēram, sūdzību reģistrācijas un ierīču marķēšanas prasībām, un ir izdevusi papildus noteikumus, lai nodrošinātu nepārtrauktu atbilstību šajās jomās savā jaunajā regulējumā (Oyster & Laroche, 2024). Pastāv arvien pieaugoša vienprātība par medicīnas ierīču ražotāju un izplatītāju nepieciešamību pielāgot savas kvalitātes vadības sistēmas, iekļaujot standartus, piemēram, ISO 13485, lai apmierinātu atbilstību gan regulatīvajām prasībām, gan arī tirgus izmaiņu tendencēm. Šis standarts uzsver spēcīgu klientu orientāciju, rūpīgu dokumentāciju un sistēmisku vadības pārskatu procesu, kas ir būtiski, lai uzturētu augstu produkta kvalitāti un drošību (Dhilawala, 2022).

Kopumā nepieciešamību veikt pētījumus šajā jomā pastiprina globālās notiekošās regulatīvās izmaiņas un sarežģītā starptautisko standartu, piemēram, ISO 13485, integrēšana esošajās kvalitātes pārvaldības sistēmās. Kopumā šāda integrācijas procesu izpēte un ieviešana medicīnas ierīču nozarē palīdz labāk orientēties mainīgajā regulatīvajā vidē un uzlabot uzņēmumu darbības efektivitāti.

Analizējot kopīgo un atšķirīgo starp ISO 9001 un ISO 13485 standartiem un to prasībām, autors konstatē, ka būtiski ir ņemt vērā ne tikai standartus, bet arī to versijas. ISO 9001:2015 standarts ir vispārīgāks un universālāks, piemērojams praktiski jebkādam industrijām un nozarēm to organizatoriskās efektivitātes un klientu pieredzes uzlabošanai (Driņķe, 2019), savukārt ISO 13485:2016 standarts ir atvasināts no ISO 9001:2008 standarta, tālāk ir specifiski pielāgots medicīnas tehnoloģiju industrijai un ir papildināts ar prasībām, kas nodrošina augstāku medicīnisko ierīču drošību un harmonizāciju ar likumdošanas prasībām (sk. 2. att.). Tomēr tas neietver ISO 9001:2015 standartā ieviestās augstākā līmeņa strukturālās izmaiņas, tāpēc atšķirības starp standartiem tomēr pastāv. ISO 13485 standarts daudz lielāku uzsvāru liek risku vadībai un drošībai kritisku procesu uzraudzībai (Kheir et al., 2021).

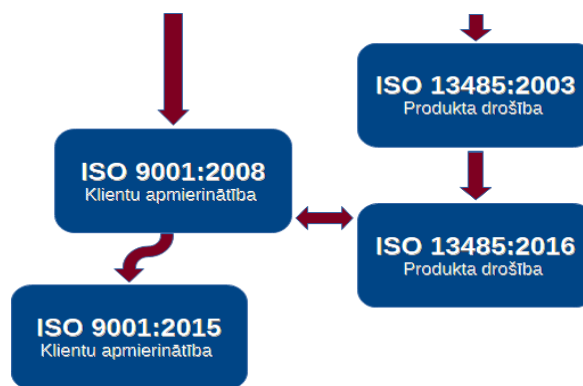

2. att.: ISO 9001 un ISO 13485 standartu korelācija (Avots: autora veidots)

Uzņēmumiem, kas darbojas medicīnas tehnoloģiju industrijā un vēlas ieviest kvalitātes pārvaldības sistēmu, pirms standarta izvēles, jāapsver savas īpašās regulatīvās prasības un riski, kas saistīti ar to piedāvātajiem produktiem. ISO 13485 prasības būtībā paplašinātā formā ietver arī ISO 9001 standarta prasības, pielāgotas medicīnas tehnoloģiju industrijai. Līdz ar to IVS sertificēšana atbilstībai abiem standartiem var būt neefektīva un var izraisīt neefektīvu uzņēmuma resursu izlietošanu. No otras puses, Latvijas Republikas publiskajos iepirkumos ar vien biežāk parādās prasības piegādātājam būt sertificētam atbilstoši ISO 9001 standarta prasībām ar augstu risku tikai pēc ISO 13485 sertificētiem uzņēmumiem tikt diskvalificētiem no tālākas dalības publiskajos iepirkumos dēļ šīs neatbilstības, lai arī viņu IVS pamatā pilnībā atbilst arī augstāk minētajam ISO 9001 standartam.

### Pētījuma metodoloģija

Pētījumā izmantotās metodes un process tika veidoti, lai sniegtu detalizētu ieskatu par integrētās kvalitātes vadības sistēmas mijiedarbību ar ISO 9001 un ISO 13485 standartiem. Pētījums tika balstīts uz literatūras pārskatu un papildināts ar empīriskiem datiem, kas iegūti caur uzņēmuma IVS dokumentu analīzi un atbildīgo amatpersonu padziļinātām intervijām.

Literatūras pārskats tika veikts, lai saprastu un izanalizētu esošos pētījumus un publikācijas, kas saistītas ar kvalitātes vadības sistēmām, īpaši koncentrējoties uz ISO 9001 un ISO 13485 standartiem. Šī analīze ļāva identificēt būtiskus teorētiskos aspektus un praksē izmantotās pieejas kvalitātes vadības jomā, kā arī to, kā šie standarti mijiedarbojas un papildina viens otru.

Datu vākšana notika divās galvenajās fāzēs – dokumentu analīzē un intervijās. Dokumentu analīze tika veikta uzņēmuma IVS dokumentācijas analīzē. Šis process ietvēra detalizētu esošo vadības sistēmu dokumentu, procedūru, politiku un iekšējo auditu ziņojumu izpēti, lai izprastu, kā tiek ievēroti ISO standarti un kādas ir esošās IVS stiprās un vājās puses. Tika izmantoti pieejamie dati, piemēram, kvalitātes rokasgrāmata, sūdzību reģistrs, iekšējo un ārējo auditu ziņojumi. Padziļinātas intervijas tika organizētas ar vadītāju un kvalitātes vadības speciālistu. Katra intervija tika transkribēta, lai nodrošinātu precīzu un detalizētu informācijas fiksāciju. Intervijās tika izvirzīti jautājumi par to, kā tiek uzturēta un pilnveidota IVS, mērķtiecīgi fokusējoties uz jaunu prasību ieviešanu un esošo procesu uzlabošanu saskaņā ar ISO 13485 standarta prasībām.

### Pētījuma rezultāti

Pētījuma rezultāti par IVS atbilstības ietveršanu ISO 13485 standarta prasībām medicīnas ierīču nozarē rāda, ka, ņemot vērā pieaugošās regulatīvās un tirgus prasības pēc augstas kvalitātes un drošības, šī standarta integrācija kļūst aizvien svarīgāka. Arī Eiropas Savienības jaunās regulas par medicīnas ierīcēm un in-vitro diagnostikas medicīnas ierīcēm nosaka detalizētākas prasības kvalitātes vadības sistēmām un produkta dzīves cikla pārvaldībai, kas pilnībā saskan ar ISO 13485 standarta prasībām par risku pārvaldību. Tomēr šis standarts neaptver visas aktuālās regulu prasības, kas nozīmē, ka uzņēmumiem būs jāpapildina savas IVS ar īpašām papildus procedūrām un speciāla atbilstības sertifikācija.

Rezultāti arī izgaismoja, ka ISO 9001 vai ISO 13485 sertificētiem uzņēmumiem regulatorās atbilstības nodrošināšanai ir priekšrocības, jo tiem jau ir izstrādāts IVS ietvars un papildus procedūru ieviešana pilnai atbilstībai ir daudz vienkāršāka un ātrāka.

Literatūrā tiek atzīmēta arī arvien pieaugošā vienprātība par nepieciešamību medicīnas ierīču ražotājiem un izplatītājiem pielāgot savas kvalitātes vadības sistēmas, iekļaujot atbilstību vispārējiem, starptautiskiem standartiem, piemēram, ISO 13485. Šis standarts uzsver rūpīgu risku analīzi, spēcīgu klientu orientāciju, rūpīgu dokumentāciju, produktu izsekojamību un sistēmisku vadības pārskatu procesu, kas ir būtiski, lai uzturētu augstu produkta kvalitāti un drošību.

Visbeidzot, analizējot kopīgo un atšķirīgo starp ISO 9001 un ISO 13485 standartiem (sk. 1. tabulu), pētījums atklāj, ka organizācijām, kas darbojas medicīnas tehnoloģiju industrijā, būtu jāapsver specifiskās regulatīvās prasības un riski pirms izvēlas atbilstošu standartu. ISO 13485 iekļauj būtiskas ISO 9001 prasības, kas ir pielāgotas medicīnas tehnoloģiju industrijai un tās sertificēšana var būt ekonomiski efektīvāka, salīdzinot ar abu standartu paralēlu ieviešanu un sertificēšanu.

**1. tabula.** ISO 9001 un ISO 13485 standartu kopējās un atšķirīgās prasības (Avots: autora apkopojums)

Joma	ISO 9001	ISO 13485	Atsauce standartā
Darbības joma	Vispārīga, piemērojama jebkuram uzņēmumam	Specifiska medicīnas tehnoloģiju jomai un ar to saistītiem pakalpojumiem	ISO 9001: Sadaļa 1, ISO 13485: Sadaļa 1

Dokumentācija	Dokumentēta informācija IVS vajadzībām	Paplašināta dokumentācija arī regulatīviem mērķiem	ISO 9001: Sadaļa 4.4, ISO 13485: Sadaļa 4.2
Risku pārvaldība	Uzsvars uz vispārējiem IVS riskiem	Uzsvars uz produkta un procesa riskiem	ISO 9001: Sadaļa 6, ISO 13485: Sadaļa 7.1
Normatīvā atbilstība	Vispārīga prasība atbilstībai regulām un likumdošanai	Specifiskas procedūras atbilstībai regulām un vietējai likumdošanai	ISO 9001: Sadaļa 6, ISO 13485: Sadaļa 7.2.1
Produkta realizācija	Plānošana un kontrole produktu un pakalpojumu nodrošināšanai	Liela uzmanība produkta drošībai un izsekojamībai	ISO 9001: Sadaļa 8, ISO 13485: Sadaļa 7.5
Uzraudzība un uzlabošana	Uzsvars uz klientu apmierinātību un nepārtrauktu tās uzlabošanu	Liels fokuss uz koriģējošām un preventīvām darbībām, kas specifiskas medicīnas iekārtām	ISO 9001: Sadaļas 9 & 10, ISO 13485: Sadaļas 8.2 & 8.3

Pētījuma ietvaros tika izpēta uzņēmuma integrētā vadības sistēma (IVS), kas pašlaik atbilst ISO 9001 standartam, ar mērķi novērtēt, kādi būtu nepieciešamie uzlabojumi un papildinājumi, lai panāktu atbilstību arī ISO 13485 standartam. Analīze parādīja, ka uzņēmumam ir jāveic būtiski uzlabojumi un papildinājumi, lai sasniegtu pilnīgu atbilstību ISO 13485 prasībām. Lai gan esošā dokumentācija un procedūras nodrošina labu pamatu, tās nepieciešams specifiski paplašināt, iekļaujot detalizētākus medicīnisko ierīču specifiskus riska pārvaldības protokolus un produktu dzīves cikla pārvaldības procedūras. Personāla apmācības programmas būs jāpaplašina ar medicīnas ierīču kvalitātes pārvaldības un riska novērtējuma aspektiem, lai atbilstu jauno standartu prasībām. Tāpat būs nepieciešams palielināt iekšējo auditu biežumu un detalizētību, lai nodrošinātu efektīvāku uzraudzību pār identificētajām kritiskajām darbības jomām. Šie uzlabojumi ļaus uzņēmumam ne tikai atbilst ISO 13485 standarta prasībām, bet arī paaugstināt vispārējo produktu kvalitāti un drošību, kas ir kritiski svarīgi strādājot medicīnas ierīču nozarē. Veiktās intervijas ar uzņēmuma vadītāju un kvalitātes vadītāju, sniedz svarīgus ieskatu uzņēmuma integrētās vadības sistēmas pašreizējā stāvoklī un tālākajiem plāniem attiecībā uz ISO 13485 standarta ieviešanu. No interviju transkripcijām autors izveidoja svarīgāko jautājumu saīsinātu apkopojumu ar vadošo amatpersonu ieskatu uzņēmuma vadības sistēmā un tās attīstības perspektīvās (sk. 2. tabulu).

**2. tabula.** Galveno speciālistu interviju transkripciju kopsavilkums (Avots: autora apkopojums)

Jautājums	Uzņēmuma vadītāja atbildes	Kvalitātes vadītāja atbildes
1. Kā jūs uzturat un pilnveidojat sava uzņēmuma IVS?	Tiek veikti regulāri iekšējie un ārējie auditi, notiek darbinieku apmācības un iesaiste kvalitātes sistēmas uzturēšanas un uzlabošanā.	Notiek regulāras procesu un procedūru aktualizācijas un pilnveides, tiek veiktas apmācības, tiek veikta ISO 9001 atbilstības regulāra pārskatīšana un, nepieciešamības gadījumā, procedūru un dokumentu aktualizēšana.
2. Vai esat iepazinies ar ISO 13485 prasībām un kā jūs plānojat tās integrēt esošajā IVS?	Kā lielākais iztrūkums ir identificēta nepieciešamība izveidot detalizētu riska analīzes un pārvaldības procesu un pilnveidot produktu regulatīvās atbilstības dokumentēšanu.	Izstrādāts plāns jaunu procedūru ieviešanai un esošo procesu uzlabošanai, iepļānotas nepieciešamās darbinieku apmācības. Ir būtiski jāpārstrādā un jāpaplašina sūdzību izskatīšanas process ieviešot problēmu pamatcēloņu analīzi un atbilstošu korektīvo vai preventīvo darbību veikšanu un to rezultātu

		verificēšanu.
3. Kādas izmaiņas vai uzlabojumi jau ir veikti?	Papildināta produktu kvalitātes kontrole, uzlabojot tieši regulatīvās dokumentācijas pārvaldību.	Ieviesti papildu kvalitātes kontroles un uzraudzības punkti, uzlabota dokumentācija, pastiprināta materiālu izsekojamība. Ieviesta mēraparatūras regulāra kalibrēšana un uzraudzība, izveidota noliktavas telpu temperatūras un mitruma uzraudzības sistēma.
4. Kādi ir galvenie sastaptie izaicinājumi šajā integrācijas procesā?	Nepieciešamo finanšu resursu plānošana un novirzīšana. Nākas saskarties ar daudziem tehniskiem un organizatoriskiem jautājumiem	Izdalīto resursu sadalīšana un novirzīšana, darbinieku apmācība, piegādātāju un partneru atbilstības izvērtēšana un nodrošināšana.
5. Kādi ir turpmākie paredzēti ieviešanas soļi?	Pilnveidot IT infrastruktūru, un tad veikt pilnīgu sistēmas auditu.	Integrēt ISO 13485 prasības visās vadības sistēmas procedūrās un dokumentos, veikt personāla apmācību ciklu un iekšējos auditus un sagatavoties ārējam IVS sertifikācijas auditam.

Uzņēmuma vadītājs norādīja, ka sistēma ir labi uzturēta saskaņā ar ISO 9001 prasībām, kas ietver regulārus iekšējos un ārējās uzraudzības auditus, kā arī aktīvu darbinieku iesaistīšanu kvalitātes sistēmas uzturēšanā un uzlabošanā. Tomēr vadītājs uzsvēra, ka ir identificēta nepieciešamība ieviest specifiskas izmaiņas, lai atbilstu ISO 13485 standartam, kas prasa detalizētāku pieeju riska pārvaldībai un produkta drošībai.

Kvalitātes vadītājs apstiprināja, ka ISO 9001 nodrošina stabilu pamatu, taču izteica vajadzību paplašināt procedūras, lai integrētu ISO 13485 specifiskās prasības. Tika atzīmēts, ka jau ir veikti piemēroti uzlabojumi, piemēram, paplašinātas kvalitātes kontroles uzraudzības metodes un uzlabota dokumentācijas pārvaldība, tomēr vēl joprojām pastāv nepieciešamība pēc papildu procedūrām saistībā ar riska novērtēšanu un kontroli.

Abu interviju rezultāti liecina, ka, lai gan uzņēmums ir veiksmīgi ieviesis ISO 9001 prasības un to uzturēšanai tiek pielietotas efektīvas metodes, gaidāmā ISO 13485 ieviešana prasīs būtiskus uzlabojumus un papildinājumus. Šie uzlabojumi ietver padziļinātāku darbu ar riska pārvaldības sistēmām, produktu izsekojamību un darbinieku apmācību attiecībā uz jaunajiem standartiem. Tas nodrošinās ne tikai atbilstību jaunajām regulatīvajām prasībām, bet arī uzlabos kopējo produkta kvalitāti un drošību, kas ir izšķiroši svarīgi medicīnas ierīču nozarē.

### Secinājumi

Apkopojot pētījuma kopējos rezultātus autors konstatē, ka integrētās vadības sistēmas izvēle var būtiski ietekmēt medicīnisko ierīču drošumu un efektivitāti un nozares uzņēmumiem par prioritāti galvenokārt jāizvirza pacientu drošība un atbilstība regulatīvajām prasībām. Gan ISO 9001:2015, gan ISO 13485:2016 ir vērtīgi kvalitātes vadības sistēmas standarti, kas katrs savā veidā var sniegt pienesumu uzņēmuma darbības efektivitātes veicināšanai. Tomēr, lai demonstrētu pilnu atbilstību Eiropas Savienības aktuālajai likumdošanai, uzņēmumiem ir jāizstrādā un savā IVS jāintegrē vēl arī papildus procedūras. Galvenie autora secinājumi par uzņēmumam veicamajiem darbiem ir sekojoši:

Nepieciešamība pēc korektīvo un preventīvo darbību procedūras. Lai uzņēmums nodrošinātu pilnīgu atbilstību ISO 13485 standarta prasībām, ir būtiski izstrādāt un ieviest arī korektīvo un preventīvo darbību (Corrective and Preventive Actions - CAPA) procedūru. ISO 13485 uzsver nepieciešamību arī





pēc efektīvas kvalitātes vadības sistēmas, kur CAPA procedūra spēlē centrālu lomu. Šī procedūra ir būtiska, lai identificētu, analizētu un novērstu problēmas un potenciālos riskus, kas var ietekmēt medicīnas ierīču drošību un kvalitāti.

Nepieciešamība pēc detalizētas risku analīzes un pārvaldības procedūras. Uzņēmuma pašreizējā integrētā vadības sistēma, kas atbilst ISO 9001 standartam, nodrošina stabilu pamatu kvalitātes vadībai, tomēr pētījums norādīja uz būtisku nepieciešamību izstrādāt un ieviest specifiskāku un detalizētāku risku izvērtēšanas un pārvaldības procedūru, kas atbilstu ISO 13485 prasībām.

Uzlabojumu nepieciešamība dokumentācijas pārvaldības procesos. Lai gan dokumentācijas sistēma ir labi strukturēta un atbilst ISO 9001 prasībām, ir nepieciešams ieviest papildus procedūras un kontrolmehānismus, kas nodrošinātu atbilstību ISO 13485 standarta prasībām. Tas ietver detalizētākas produkta izsekojamības, kvalitātes kontroles un dokumentācijas pārbaudes procedūras.

Darbinieku papildus apmācības un zināšanu uzlabošana. Lai veiksmīgi ieviestu ISO 13485 standartu, ir būtiski nepieciešams uzlabot darbinieku apmācību programmas, pievēršot lielāku uzmanību specifiskām prasībām un procedūrām, kas nepieciešamas tieši medicīnas ierīču nozarē. Tas palīdzēs nodrošināt, ka visi darbinieki ir pilnībā informēti un spēj efektīvi piemērot jaunās zināšanas praksē.

Integrācijas un atbilstības uzlabošana starptautiskā mērogā. Ņemot vērā globālās regulatīvās izmaiņas un tendences, uzņēmuma integrētajai vadības sistēmai ir jābūt gatavai ne tikai atbilst vietējās likumdošanas prasībām, bet arī efektīvi integrēt starptautisko regulējumu. ISO 13485 ieviešana palīdzēs uzņēmumam uzlabot produktu atbilstību regulatīvajām prasībām un paaugstināt to drošību un efektivitāti, paaugstināt savu konkurētspēju un reputāciju starptautiskajā tirgū, vienlaikus nodrošinot visā pasaulē pieņemtus un izprotamus, augstākus drošības un kvalitātes standartus, kas novedīs pie uzņēmuma konkurētspējas un tirgus pozīciju uzlabošanas, tādējādi apstiprinot autora pētījuma sākumā izvirzīto hipotēzi.

### Izmantotās literatūras un informācijas avotu saraksts

Brkic, K. Z. (2023). MDR compliance - How to achieve it, and can ISO 13485 help? <https://advisera.com/13485academy/blog/2020/03/09/how-can-iso-13485-help-with-mdr-compliance/>

Dhilawala, A. (2022). A guide to ISO 13485 for medical device startups. <https://galendata.com/a-guide-to-iso-13485-for-medical-device-startups/>

Driņķe, Z. (2019). *Kvalitātes vadības sistēmas Latvijas mazo un vidējo uzņēmumu konkurētspējas paaugstināšanai*. Biznesa augstskola "Turība".

Eiropas parlamenta un padomes regula (ES) 2017/745 (spēkā esošā redakcija, 05.04.2017). *Eiropas Savienības Oficiālais Vēstnesis*. <https://eur-lex.europa.eu/legal-content/LV/TXT/HTML/?uri=CELEX%3A32017R0745>

Eiropas parlamenta un padomes regula (ES) 2017/746 (spēkā esošā redakcija, 05.04.2017). *Eiropas Savienības Oficiālais Vēstnesis*. <https://eur-lex.europa.eu/legal-content/LV/TXT/HTML/?uri=CELEX%3A32017R0746>

Fortune Business Insights (2024). Medical devices market share, trends. <https://www.fortunebusinessinsights.com/industry-reports/medical-devices-market-100085>



Oyster, J., & Laroche, A. D. (2024). Top 10 Takeaways from FDA's revised quality system requirements for medical devices. <https://www.ropesgray.com/en/insights/alerts/2024/02/top-10-takeaways-from-fdas-revised-quality-system-requirements-for-medical-devices>

Kheir, O., Smedts, S., Jacoby, A., & Verwulgen, S. (2021). Efficient quality management in medtech start-ups (Based on ISO 13485). *Medical Devices: Evidence and Research*, 14, 313-319. <https://doi.org/10.2147/MDER.S320583>

LVS EN ISO 13485:2016 (2016). Medicīniskās ierīces. Kvalitātes pārvaldības sistēmas. Reglamentējošās prasības (spēkā esošā redakcija, 19.05.2016). *International Organization for Standardization*. <https://www.lvs.lv/lv/products/128224>

Davar, M. V., Desjardins, P. R., Habtemariam, A., Sklamberg, H., & Scandalios, T. M. (2024). FDA issues final rule to more closely align fda medical device quality system requirements with international consensus standard ISO 13485. <https://www.arnoldporter.com/en/perspectives/advisories/2024/02/fda-final-rule-medical-device-requirements-and-iso-13485>

Market Data Forecast. (2024). Medical Devices Market Size, Share, Growth Report. <https://www.marketdataforecast.com/market-reports/medical-devices-market>

Quality System (QS) Regulation/Medical Device Current Good Manufacturing Practices (CGMP) (spēkā esošā redakcija, 02.02.2024). FDA. FDA. <https://www.fda.gov/medical-devices/postmarket-requirements-devices/quality-system-qs-regulationmedical-device-current-good-manufacturing-practices-cgmp>



## **Elvita Ērgle. RISK MANAGEMENT PROCESSES IN INTERNATIONAL PROJECT EXPEDITIONS**

*EKA University of Applied Sciences  
Master's Study Program "International Culture Project Management"  
E-mail: [elvitaergle@gmail.com](mailto:elvitaergle@gmail.com)  
Scientific Advisor: Dr.phil., Professor Velga Vēvere*

### **Abstract**

**Research relevance:** There are 71 000 university students in Latvia who receive different study programs, of whom almost 10 000 are international students, representing more than 60 countries from all over the world. To make it more exciting for local and foreign students to study, universities and corporations offer a variety of events, and among the most popular are expedition events in which not only career-friendly but also personally satisfying and evolving experiences. The author wants to commemorate the world-famous event "Adventure racing World series," a sports expedition that brings together the world's greatest endurance athletes and students who can overcome 3-10-day expeditions that took place everywhere - North America, South America, Europe, Africa, Asia, etc. up to 59 groups participated in 2023. (WITH worldseries).

**Research goal:** To evaluate international students' experiences with risk management processes during project expeditions.

**Research method:** Questionnaire (visitors to expeditions), expert interviews (5 experts from various student authorities of Latvian universities), analysis of documents (scientific articles).

**Main findings:** In the context of international student expedition projects, effective risk management is crucial to mitigate potential risks and ensure the success of events organized on a global scale. The results of the study will be useful to expedition organisers who wants to organise an event in an international environment.

*Keywords: risk management; students; expeditions; projects; Forest expedition.*

### **Introduction**

Expeditions enable people to discover various novelties, such as Ferdinand Magellan circumnavigating the globe and discovering that the Pacific Ocean separates the Asian continent, Christopher Columbus discovering America, and Vikings discovering new lands and riches. Each event has been a kind of project in its own right, aimed at discovering something new. A project is a time-bound event carried out to create or develop a unique product, service, or result. Projects come in different sizes and require varying levels of formality and management. (Harvard University, n.d.). Risk management processes are a key component of projects, especially playing a significant role in international expeditions involving people from countries worldwide. The aim of the project is to develop a risk management guideline structure for the international student "Forest Expedition" project.

## Literature Review

Risks are an inherent part of any process of change. Risk management involves managing existing project uncertainties. It shows the way to reduce risks, the mitigation of which could cost huge sums, and to avoid them (Jangs, 2009). Project managers or risk experts need strong analytical and problem-solving skills to identify multiple risk factors. Risks are complex and multifaceted, and to track them effectively, a great tool is SWOT analysis, which identifies internal and external, existing, and potential risks. Jangs summarized in his book the main elements because risk analysis is crucial:

- Enables the prediction of serious threats to the project before they occur;
- Helps to immediately implement risk reduction actions;
- Provides the opportunity to pre-establish an emergency action plan;
- Improves the decision-making process;
- Provides valuable information for negotiations with suppliers;
- Allows for clear accountability for various risks and accordingly their monitoring;
- Helps to create a project environment where unpleasant surprises do not occur;
- Promotes a creative approach to the project and idea generation;
- Allows the project manager to be an effective leader rather than constantly dealing with crisis resolution. (Jangs, 2006)

The relevance of risk management increases every year due to new technologies, unforeseen pandemics, and other circumstances, which not only require more frequent reassessment of existing risks but also caution against new risks, resulting in the revision of risk management strategies and institutional action plans (Finanšu ministrija, 2021). Business management experts need to keep abreast of developments in technologies (artificial intelligence), biotechnology (gene editing, e-health), e-commerce (digitized services), climate change (improving environmental diversity). This is the foundation of organizational competitiveness and development.

The most widespread types of risk in the project process are the following:

- Economic risk - financial losses, the possibility of losing sponsors;
- Performance risk - the possibility that equipment will not work during a performance, or that one of the event participants will not show up;
- Psychological risk - location, or a similar event with a bad reputation has previously taken place;
- Mental risk - health and safety issues (Shone & Perry, 2013).

Summing up several terms, an expedition is a journey undertaken by a group of people for a specific purpose (such as exploring a remote location or conducting research). (Britannica Dictionary, 2024) Therefore, expeditions help to organize various scientific research, excursions to unknown places, cohesive and sporty time spent in the great outdoors. In Latvia, various types of expeditions are taking place, targeting different audiences such as the forest expedition, which helps 6th-grade students learn about nature in the forest together, the green forest expedition, which takes place every summer to measure the entire Latvian coast, and the Latvian expedition organization, which conducts photo orientation throughout Latvia. The author wants to mention that Latvian universities also organize



expeditions for first-year or foreign students, allowing them to explore Latvian nature and enjoy additional adventures. It must be said that such events are organized on a smaller scale or rarely, as the biggest obstacle is finances, low participation, weather conditions, illness, or other reasons.

Reviewing on a large scale - annually, National Geographic organizes international student expeditions, regardless of which journey you choose, you will travel with a purpose. Interactive projects, such as knowledge about the latest technology used in combating climate change, research on wildlife threats with scientists, or creating a photography portfolio, learning to capture images that tell a story, will deepen your understanding of the communities and landscapes you visit; all of this helps to build your portfolio of experiences and share your experiences (National Geographic, n.d.).

Such a project allows students annually to choose to travel to all continents of the world, such as the Arctic Canada, Norway, Japan, Ecuador, Italy, Thailand, etc. National Geographic organizers offer a specific range of programs that can be mastered:

- Anthropology, culture, and traditions;
- Climate and geology;
- Innovation and technology;
- Photography;
- Wildlife conservation.

National Geographic's student expedition is very extensive and multifaceted, but at the same time, the project organizers adhere to specific goals. The project team had to work very hard on such a project - planning expedition programs, inviting industry experts, and mentors who study at the world's most prestigious universities to help event participants, who are senior high school students.

Organizing international expeditions is a huge challenge for project organizers and, consequently, a risk. Initially, the location of the event must be explored, potential risks identified (river, cliff, animals, educational or military territory), it must be clarified whether signs need to be marked, a map created, or instructions followed. Industry experts need to be involved who offer an objective view of the situation, predict and manage risks. Therefore, the participation of mentors must be evaluated, who listen and help support the young person in the way he needs, because expeditions are of different levels, and each participant is different - what may seem like an easy event to one may be overcoming various emotional and physical barriers to another. Mainly, the marketing of international expeditions needs to be planned because it allows companies to reach a larger potential customer base. Social networking has developed the human need to create connections and relationships with others, as well as provides interaction, overcoming barriers between the public and private communication spheres (Viola, 2022).

### **Research Methodology**

Within the scope of the study, the author developed a survey on risk management processes in international student project expeditions, aiming to ascertain the opinions of foreign students on risk processes during expeditions. The survey's target audience was divided into two parts: one consisting of participants in expeditions who could provide an assessment of risk processes at the event, and the other consisting of those who could not provide a broader perspective as they had not participated in expeditions. Quantitative online survey methods were used to collect research data. The survey was prepared in the format of a Google Forms questionnaire and was published from January 2, 2024, to



January 19, 2024. It was distributed on the social platform network site "Facebook.com" in several groups of foreign students to more precisely reach the research objective, thus employing the "snowball sampling" method. The results were compiled and analyzed using the Google Forms application. In the graphs, the research author used a percentage breakdown across the total number of respondents. The survey questionnaire is attached as Appendix 2. The questionnaire consists of 3 blocks, totaling 13 questions, which were completed by 307 respondents aged 17-60+ years, in an online environment. The survey questionnaire was completely anonymous, in compliance with data protection laws.

Within the scope of the study, the author conducted a practical investigation, namely interviews, as one of the data collection methods, with representatives of the student self-government boards of Latvian universities to ascertain how expeditions for foreign students are organized and whether event organizers assess risks. One of the survey methods used in the study was a semi-structured interview. The interview comprised ten open-ended questions, conducted online via email and the "WhatsApp" messaging platform, with 5 industry representatives:

- Andis Polaks - Head of the International Department of the Student Council of the University of Latvia
- Renāte Silakalne - Head of the Student Self-Government of the University of Latvia, Faculty of Life Sciences and Technologies
- Renāte Kačerovska - Coordinator of the International Direction of the Student Self-Government of RISEBA University
- Ieva Stallīte - Head of the International Cooperation Department at Turība University
- Toms Fridrihsons - Head of the External Communications Department of the Student Self-Government at Riga Technical University.

## Results

Participated in the questionnaire 184 (65.5%) women, 93 (34.5%) men and 30 respondents were unwilling to express their gender thus following and following gender equality laws. To participate in the survey, respondents were free to choose from a dropdown menu, which helped to precisely determine the nationality of the person filling out the questionnaire. The majority (81.3%) of respondents were in the age group of 30 to 40 years, while (31.3%) of respondents were in the age group of 23 to 30 years, and (12%) of those surveyed were in the age group of 17 to 22 years. The author mentioned that statistics show that 61.4% of the world's population, or 4.95 billion people, use social networks, of which the majority are 68.5 million Y or millennial generation (born between 1981 and 1996) and 56.4 million users are from the Z generation (born between 2001 and 2012).

The author aimed to understand why respondents attended expedition events. The majority indicated that 66.7% attended to support friends, 55.6% participated in expeditions to seek new adventures, and 44.4% to learn and experience new emotions, knowledge, and skills. Additionally, many expressed that they participated in expeditions to test their skills, enjoy the sense of community, and attempt to motivate themselves to step out of their comfort zone or overcome their fears (see Fig.1).

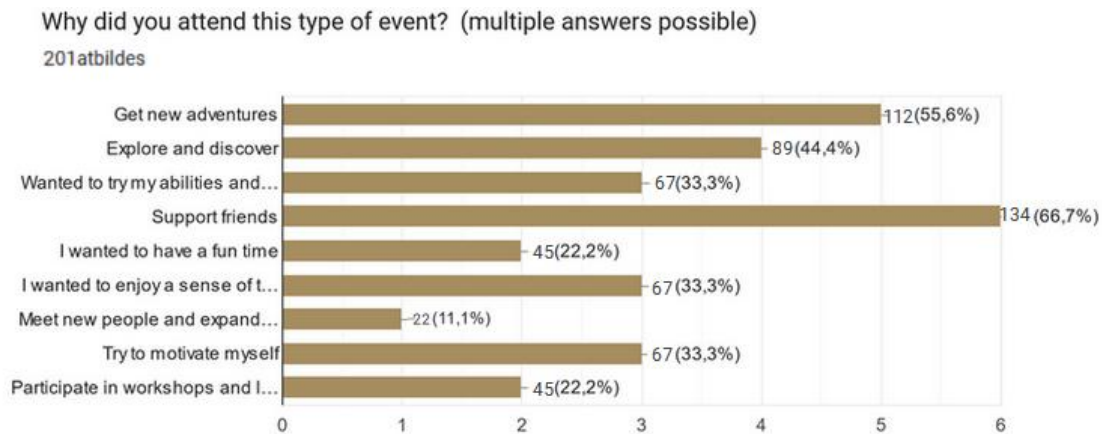

**Fig. 1.** Find out why respondents took part in expeditions (Source: Created by the author)

Respondents to the next question had to assess whether event organisers cared enough about the risks of events, 178 respondents said they agreed with 89 of whom expressed their opinion that organisers were thinking about the risks very much, while 22 assessed that they disagreed with the claim. The author concludes that most respondents faced some measure risks that have affected their assessment.

The author wanted to determine how satisfied respondents were with the expedition event on a scale from 1 to 10 (1 being poor, 10 being excellent). 22 respondents expressed their opinion that the event was rated a 6 on the scale, meaning fairly good, and 22 respondents rated the event at 7 points, indicating good. 45 respondents indicated that the event was rated at 8 points, meaning very good, 67 respondents chose a score of 9 - excellent, while it should be noted that 45 respondents liked the event to the fullest extent, giving it a perfect score of 10.

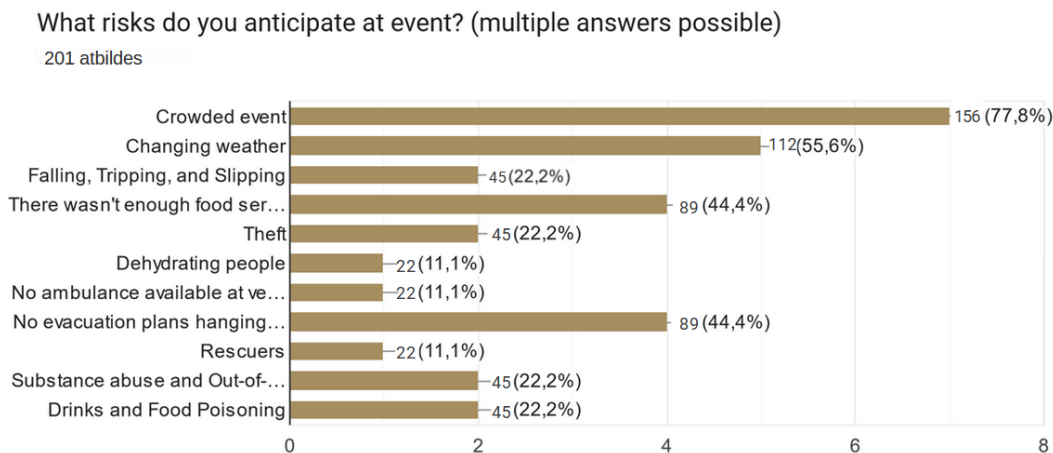

**Fig. 2.** Expedition risk process (Source: Created by the author)

The author wanted to know what risk factors respondents have faced so far at valuable events. Many respondents faced a crowded event at 77.8 %, with 55.6 % saying there was a change in weather during the events, which certainly had an impact on enjoying the event. By contrast, the majority of 44.4% indicated that the measure did not provide sufficient food services, no evacuation instructions were

provided. While 22.2 % say the measure had risks such as slipping, falling off, which could be affected by inappropriate cover, theft, controlled drinking of alcohol, poisoning of drinks or food. As a result, 11.1 % said there was dehydration at the event, there was no ambulance service or rescuers as police officers or firefighters who can quickly and effectively address risks.

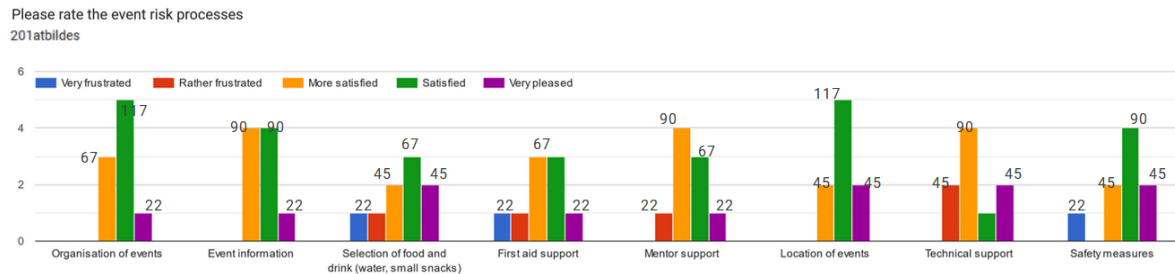

**Fig. 3.** Expedition risk process (Source: Created by the author)

The majority of 117 respondents were satisfied with the organization of the expedition (level 4), 22 were very satisfied (level 5), while 67 felt rather satisfied (level 3). The most common rating was 4, both in mode and median, indicating that the overall evaluation of the event organization from 201 respondents on a scale of 5 was 3.9. Respondents' responses regarding satisfaction with event organization.

In the next section, the author wanted to determine respondents' assessment of event informativeness - 90 acknowledged being satisfied, choosing level 3, 90 respondents expressed that they were rather dissatisfied (level 5), and 22 consecutively chose level 5. The most common rating was 3 and 4, both in mode and median, with an average rating of 3.7 out of 5. Respondents' responses regarding satisfaction with the provided and available event information. The selection of food and drinks (water, light snacks) was rated as satisfactory by 67 respondents (level 4), 45 indicated they were very satisfied - choosing level 5, 45 rated it as rather satisfying (level 3), while the remaining 44 respondents rated it as dissatisfactory (levels 2 and 1). The most common rating was 4, both in mode and median, with an average rating of 3.4 out of 5. Regarding first aid support during the event, the majority of 66 respondents noted that they were rather satisfied (level 3), 68 were satisfied (level 4), while the remaining 22 respondents were very satisfied. Conversely, 44 respondents were dissatisfied or rather dissatisfied with the first aid support. The most common rating was 3 and 4, both in mode and median, with an average rating of 3.2 out of 5. Respondents' responses regarding satisfaction with the provided and available first aid support quality.

The assistance or mentoring during the event was satisfactory for the majority of respondents; 157 out of 201 chose level 4, while the remaining 22 considered themselves very satisfied, but 22 were dissatisfied with the location chosen by the organizers. The most common rating was 3, both in mode and median, with an average rating of 3.4 out of 5. Respondents' responses regarding satisfaction with the event location. As for the suitability of the event location. it was satisfactory for the majority of respondents; 117 out of 201 chose levels 3 and 4, while the remaining 22 considered themselves very satisfied, and 67 were satisfied with the technical support during the event. The most common rating was 4, both in mode and median, with an average rating of 4.1 out of 5. Respondents' responses regarding satisfaction with the provided and available mentoring support. Technical support (tents, microphone, speaker) was rated as dissatisfactory (levels 2 and 3) by 135 respondents, 22 rated it as dissatisfactory (level 1), while the remaining 67 respondents rated it as very satisfactory (level 5). The most common rating was 4, both in mode and median, with an average rating of 3.0 out of 5. Respondents' responses





regarding satisfaction with event technical support. Safety measures, or whether safety regulations were followed during the event, were rated as satisfactory (levels 4 and 5) by 135 out of 201 respondents, while the remaining 67 expressed dissatisfaction with the safety of the event. The most common rating was 4, both in mode and median, with an average rating of 3.7 out of 5. Respondents' responses regarding satisfaction with event safety.

Summarizing interview responses, the main question *"Have you organized collaboration events such as expeditions, photo orienteering, educational walks for international students?"* all Students' council representatives unanimously have organized small events for international students - photo orienteering, dinners with Latvian themes, boat trips on the Gauja River, etc., which helped them to adapt more easily to the new country and its culture. However, most university Students' councils cooperate with ESN - Erasmus Student Network, where all Erasmus students from different countries are involved; thanks to the ESN organization, universities can interact more effectively with international students. Adding to the next question about student response, the majority emphasized that it is unbalanced. 10 to 20 students may attend events because many students lack time due to study assignments or part-time jobs, and many international students have prejudices and fears, so the same students attend events. Therefore, the cooperation offered by ESN improves the attendance of international students.

Next, the author wanted to find out *"What problems did you encounter in these events organized for international students?"* The interviewees emphasized that language barriers are one of the problems - accents make it difficult to understand and engage in discussions. Another problem is the time interval - many students do not arrive on time, which affects the event itself and its schedule. The third problem is cultural diversity - many international students do not want to or are even afraid to participate in events because they will have to communicate and collaborate with other foreign students to avoid crossing cultural and communication boundaries - students do not participate in events.

The interview author wanted to know: *"What do you think are the risks of events for a foreign student event?"* Opinions were many and varied: conflict situations - if alcohol, state of health is still involved - allergies, communication and failure to meet a visit plan. The author agrees because these are the most significant risks that can occur at any of the foreign student events, but they can be prevented in time if event organizers have developed good communication skills with participants and are already informing them in time - what problems can be if the rules are not followed.

In conclusion, the author asked a general question: *"What would be the 3rd main risks - on international student project expeditions where European and Baltic universities participate?"* The responses varied: attendance at events - whether information from event organizers comes down to the right recipient, which further promotes building an internal university team. Student relationships - cultural differences. Visitor diseases and phobias - which can lead to accidents or poor health conditions. National legislation and policies, insurance opportunities and planned programmes so that participants have spent their time fully. Respect for neutrality on political, religious issues when planning an expedition programme so that each gender can overcome the obstacles of the event in accordance with its own efforts.

## Conclusions

During the research, the authors made the following conclusions:

- Survey statistics indicate that the majority of respondents have encountered risk processes in various expeditions.



- The survey results show that 50% of respondents attend student expeditions based on recommendations from friends or professors, aiming to spend quality time and make new friends.
- Interview results indicate low interest from international students in participating in collaboration events or local student activities organized by Latvian university Student Councils, due to cultural and time barriers.
- According to the survey results, the majority of respondents expressed that the biggest risks in expeditions are illness, event non-attendance, communication barriers, time mismanagement, and inefficient event planning.

### References

- Britannica Dictionary (2024). *Terms*. <https://www.britannica.com/dictionary/expedition>
- Finanšu ministrija (2021). *Risku vadības vebinārs*. <https://www.fm.gov.lv/lv/risku-vadibas-vebinars-2021>
- Harvard University (n.d.) HUIT *Project Management*. <https://pmo.huit.harvard.edu/what-is-a-project>
- Jangs L.T. (2006). *Kā vadīt projektu*. Zvaigzne ABC.
- National Geographic (n.d.). *Student travel*. <https://natgeostudenttravel.org/programs/>
- Shone, A., & Parry. B. (2013). *Successful event management a practical handbook*. Cengage Learning EMEA
- Sproutsocial.com (2024). Social media demographics to inform your 2024 strategy. <https://sproutsocial.com/insights/new-social-media-demographics/>
- Viola., J., K. (2020). *Young Peoples civic identity in the digital age*. Imperial College London.



## **BUSINESS ADMINISTRATION: Ārzemju studentu sekcija**



## **Dmitriy Ivanchenko. CHALLENGES AND SOLUTIONS FOR LATVIAN SMALL AND MEDIUM ENTERPRISES IN SUSTAINABILITY REPORTING**

*EKA University of Applied Sciences  
Master's Study Program "Business Administration"  
E-mail: idv.moscow@gmail.com  
Scientific Advisor: Dr.oec., Professor Jeļena Titko*

### **Abstract**

**Research relevance:** According to the Annual Report on European SMEs 2021/2022 "SMEs are critical to the success of the sustainability transition in the EU". According to the Institute of Chartered Accountants in England and Wales "Just 8% of SMEs reporting on sustainability issues".

**Research goal:** The goal is to identify challenges and solutions for Latvian small and medium enterprises in sustainability reporting.

**Research methods:** To achieve the goal of the research the analysis of publicly available documents of Latvian SMEs was performed (sustainability reports, non-financial reports, ESG reports). Besides the interview with top managers of Latvian SMEs we're contacted.

**Main findings:** In the result of the author's conducted research challenges in sustainable reporting for Latvian SMEs will be found.

*Keywords: sustainability reporting SME; sustainability transition; sustainable development.*

### **Introduction**

The relevance of sustainability reporting among small and medium-sized enterprises (SMEs) in Latvia is a crucial topic in today's global business landscape. With an increasing emphasis on corporate social responsibility (CSR) and the potential benefits it offers to SMEs, it is important to explore the current state of sustainability reporting practices and identify the challenges faced by Latvian SMEs in this regard. As per research findings, a significant portion of Latvian SMEs do not engage in sustainability reporting, which is concerning given the potential advantages associated with it (Nikadimovs, 2023). One pressing issue in the sector of SMEs in Latvia is the lack of trust and modernity, which has resulted in missed opportunities and unsuccessful deals with stakeholders (Nikadimovs, 2023).

Moreover, there are expected changes regarding legislation and national strategic objectives related to sustainability and corporate responsibility in Latvia. This highlights the increasing importance of sustainability reporting for SMEs at the national level, as they will need to adapt to these changes and improve the practice of making annual sustainability reports. (European Commission, 2023; Impolevičienė et al., 2024).

One more reason to improve the sustainability reporting among Latvian SMEs is the opportunity to highlight their sustainable practices. For instance, according to Eurostat data, Latvia generates relatively low levels of industrial waste compared to other EU countries. In 2020, Latvia produced around 1.3 million tonnes of industrial waste, significantly lower than larger economies like Germany (53.6 million tonnes) or France (27.2 million tonnes). (European Commission, 2022; Lee et al., 2017).



The aim of the paper is to identify the challenges and opportunities in the field of sustainability reporting for Latvian SMEs. Regarding the investigation of sustainability reporting among Latvian SMEs, considering the data from World Bank, the following hypothesis was formulated: Latvian SMEs that actively engage in sustainability reporting experience improved stakeholder trust, competitiveness, and business opportunities (Gorgels et al., 2022; World Bank, 2019), therefore, environmental consciousness and green initiatives provide a competitive advantage for Latvian SMEs in attracting global business partners and customers (Litvaj et al., 2023). On the other hand, SMEs, that do not actively pursue sustainability reporting miss out on a lot of development opportunities and are not as successful as their competitors that prepare sustainability reports. The reasoning for such hypothesis are benefits of sustainability reporting for businesses, mentioned in the reviewed sources, and projecting these factors onto Latvian business landscape.

In this research, the methodology involved conducting a survey among employees of 30 Latvian SMEs to gather insights into sustainability reporting practices. Data collection involved distributing the survey and gathering responses from the employees. Data processing was performed, applying such methods as graphical analysis, ranking method, frequency analysis, content analysis, classification analysis.

The challenges and opportunities in the field of sustainability reporting for Latvian SMEs were identified. Recommendations for Promoting Sustainability Reporting Among SMEs were suggested by the research author as a response to the research findings.

## Literature Review

Sustainability is not a recent idea. Communities of our ancestors have practiced sustainable living for generations by staying in sync with the natural environment, being aware of its boundaries, cycles, and fluctuations (Hayward, 2023; Imolore, 2023; Salah, 2023), however, as the society evolved and technical progress occurred, more the environment is faced with new factors that affect sustainable lifestyle. To examine how the understanding of the term "sustainability" has changed over time, multiple sources were studied.

After throughout result evaluation, it was concluded that the majority of sources, regardless of their publishing year, interpreted sustainability as a strategy for preserving the resource availability both in the present and the future. The earliest published definition examined was from 1987, and the newest-from 2023, however they both focused on preserving the environment for survival. The key terms from the gathered sources feature: future (mentioned in 5 sources), "environmental" (mentioned in 7 sources) and "life/living" (mentioned in 5 sources). All the definitions directly or indirectly mentioned the implementation of strategies, policies and following certain plans. That emphasizes that sustainability is not an abstract concept, but rather a structured one, with a sequence of certain actions.

Sustainability reporting is crucial for businesses, especially for small and medium-sized enterprises. It allows businesses to transparently communicate their environmental, social, and governance (ESG) performance to stakeholders, taking into the account investors, customers, employees, and the broader community. Sustainability reporting allows SMEs to transparently communicate their environmental and social performance, fostering trust among customers and investors (Ali et al., 2023; Setyaningsih et al., 2024). Sustainability reporting helps SMEs meet the evolving expectations of various stakeholders, since stakeholders are increasingly concerned about sustainability. Transparency through reporting can enhance an SME's reputation and brand value, while failure to address ESG risks could lead to reputational damage (Sage.com, 2023), (Castilla-Polo & Guerrero-Baena, 2023; Estner, 2022).



By openly disclosing their environmental impacts, social initiatives, and governance practices, SMEs can address stakeholder concerns and align their business operations with sustainable development objectives (Appiah-Kubi, 2024; Kujala et al., 2022; Setyaningsih et al., 2024). Findings show that SMEs that engage in sustainability reporting and comply with the environmentally oriented goals are perceived as more responsible and ethical, contributing to an improved brand image and corporate reputation (Castilla-Polo & Guerrero-Baena, 2023; Permatasar & Gunawan, 2023). Other findings state that also customers increasingly would rather support businesses that prioritize sustainability, and SMEs that demonstrate their commitment through reporting can benefit from increased customer loyalty (Appiah-Kubi, 2024; Chen et al., 2021).

### **Research Methodology**

In this research, the methodology involved conducting a survey among employees of 30 Latvian SMEs to gather insights into sustainability reporting practices. Data collection involved distributing the survey and gathering responses from the employees. Data processing was performed, applying such methods as graphical analysis, ranking method, frequency analysis, content analysis, classification analysis.

In order to provide a theoretical justification for the research, it is vital to discuss the existing literature and how it is relevant to sustainability reporting of Latvian SMEs. Throughout time, the researchers analyzed the landscape of sustainability reporting practices by surveying.

Several surveys have been conducted to assess the state of sustainability reporting in SMEs. These surveys provide insights into the challenges faced by SMEs, the drivers for reporting, and the potential benefits of adopting sustainability reporting practices.

The European Commission's SME Performance Review states that the share of innovating SMEs in Latvia is one of the lowest in the OECD (European Commission, 2023b). This might potentially impact their ability to adopt sustainable practices and report on them. Moreover, a study on Corporate Social Responsibility (CSR) in Latvia found that while CSR awareness is increasing, the implementation of CSR practices, including sustainability reporting, by SMEs does not progress at such rate and remains limited (Nikadimovs, 2023; Petersons & King, 2009). To address this data gap and gain a comprehensive understanding of sustainability reporting practices among Latvian SMEs as well as propose possible solutions and customized strategies to support and encourage sustainability reporting in Latvia, it is crucial to conduct a dedicated survey or study (Nikadimovs, 2023; OECD, 2022b).

Before conducting customized survey, several other reports were analyzed. To create a survey that would gather the data for this master thesis, general survey conducting principles were also explored. For the purpose of the research, the survey for Latvian SMEs was created. It covers a wide range of topics related to sustainability reporting, including company profiles, reporting practices, challenges, and stakeholder engagement. The survey was created, taking into consideration the general principles, as well as the benefits and drawbacks of the analyzed surveys.

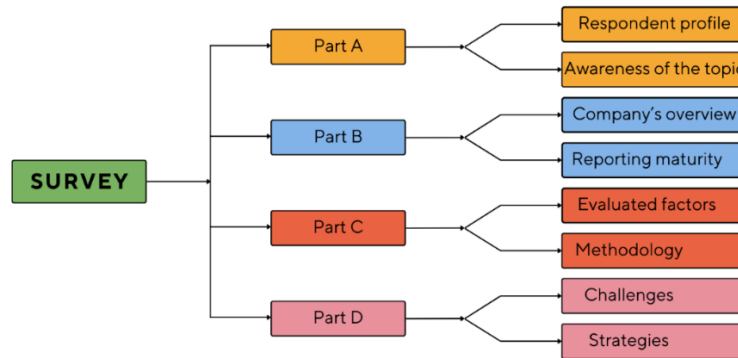

**Fig. 1.** Structure of the survey (Source: Created by the authors)

The general structure of the survey along with the covered aspects are presented in the chart above.

## Results

To evaluate the landscape of sustainability reporting among Latvian SMEs, 5 SMEs that practice sustainability reporting and publish the reports on their websites, were selected and their most recent reports analyzed. The SMEs were selected based on the report availability.

Overall, the sustainability reports of all analyzed companies demonstrate high quality across all defined principles, ensuring a comprehensive, accurate, and clear presentation of the companies' sustainability performance. However, it is important to take into the account that some of these SMEs, such as Rīgas dzirnavnieks and Orkla Foods Latvija, exist within a concern of a larger enterprise, therefore they have access to more workforce and financial resources when conducting a sustainability report, as well as the sustainability action of Rīgas dzirnavnieks comprises a part of a whole Baltic Mill enterprise.

On the other hand, most enterprises reviewed within the research, did not have a publicly available sustainability report, that leads to a conclusion that only few of the Latvian SMEs have successfully acquired the practice of sustainability reporting.

The conducted survey assisted in identifying the reasons for a relatively poor sustainability reporting rate among Latvian SMEs. Next, consider the survey results. The purpose of the survey was to gather information from various stakeholder groups to better understand their views and experiences in this rapidly evolving area.

30 responses were provided. The target audience was achieved via sending personal e-mails to a variety of SMEs and publishing the survey on the research author's social media profiles asking for participation in the questionnaire. The survey was opened for 2 weeks. Afterwards, the gathered data was interpreted and analyzed.

The answers for parts A and B of the Survey gave us the picture about profiles of respondents and SMEs they are working in. But the most important question is "For how long has your company been reporting on sustainability?" with the 93,3% answered "My company doesn't report on sustainability" (see the figure below).

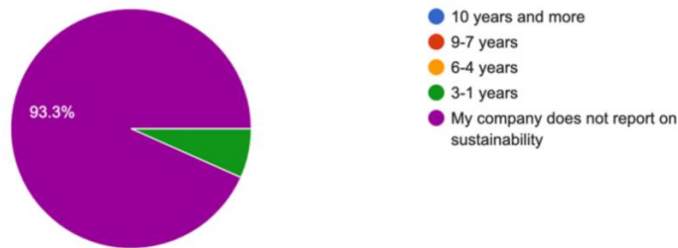

**Fig. 2.** Time of sustainability reporting in the survey (Source: Created by the authors)

The data in Part C provides insights into how the respondents view the relevance of the United Nations Sustainable Development Goals (SDGs) to their business, as well as various aspects of their company's sustainability reporting practices.

The data in Part D provides insights into the sustainability-related practices and challenges faced by the respondents' companies. The most commonly reported practice is the implementation of "green office initiatives", such as smart lighting, energy meters, waste sorting, and promoting resource efficiency within the workplace. A smaller number of respondents also indicated that their companies collaborate with sustainable suppliers and business partners.

## Conclusions

As the goal of the Paper, the challenges and opportunities in the field of sustainability reporting for Latvian SMEs were identified.

The main challenges are the following:

- Lack of Sustainability Reporting Maturity
- Limited Adoption of Sustainability Reporting Standards

The main opportunities are the following:

- Raising the awareness about sustainability reporting importance among employees through educational activities.
- Achieving a greater stakeholder engagement through conducting improved quality sustainability reports.
- Gaining an access to funding and support programs.
- Increased business performance and financial growth as a result of adjusted sustainability reporting practices.

Recommendations for Promoting Sustainability Reporting Among SMEs were suggested by the research author as a response to the research findings:

- Offer training and guidance to develop expertise in sustainability reporting (for SME Management).
- Focus on resource allocation and offer incentives to encourage SMEs to invest in sustainability reporting (for Governments and organizations).



- Concentrate on stakeholder engagement by developing online platforms for SMEs to share best practices (for SME Management).
- Collaborate with other SMEs by forming industry (for SME Management).
- Raise awareness about the issue of sustainability among employees and stakeholders, and demonstrate the implementation of best practices by organizing sustainability-targeted exhibitions (for SME Management).

## References

- Ali, H., Yin, J., Manzoor, F., & An, M. (2023). The impact of corporate social responsibility on firm reputation and organizational citizenship behavior: The mediation of organic organizational cultures. *Frontiers in psychology, 13*, 1100448. <https://doi.org/10.3389/fpsyg.2022.1100448>
- Appiah-Kubi, E. (2024). Management knowledge and sustainability reporting in SMEs: The role of perceived benefit and stakeholder pressure. *Journal of Cleaner Production, 434*, 140067. <https://doi.org/10.1016/j.jclepro.2023.140067>
- Castilla-Polo F., & Guerrero-Baena M. (2023). The business case for sustainability reporting in SMEs: Consultants' and academics' perceptions. *Sustainable Development, 31*(5), 3224-3238. <https://doi.org/10.1002/sd.2576>
- Chen, C. C., Khan, A., Hongsuchon, T., Ruangkanjanases, A., Chen, Y. T., Sivarak, O., & Chen, S. C. (2021). The role of corporate social responsibility and corporate image in times of crisis: The mediating role of customer trust. *International Journal of Environmental Research and Public Health, 18*(16), 8275. <https://doi.org/10.3390/ijerph18168275>
- Estner, V. (2022). Why SMEs can't afford to ignore sustainability reporting and how to get started. *Sustainable Business Guide*. <https://sustainable-business.guide/2022/01/21/why-smes-cant-afford-to-ignore-sustainability-reporting-and-how-to-get-started/>
- European Commission (2022). 2022 Country report – Latvia. [https://commission.europa.eu/system/files/2022-05/2022-european-semester-country-report-latvia\\_en.pdf](https://commission.europa.eu/system/files/2022-05/2022-european-semester-country-report-latvia_en.pdf)
- European Commission (2023a). 2023 Country report – Latvia. [https://economy-finance.ec.europa.eu/system/files/2023-05/LV\\_SWD\\_2023\\_614\\_en.pdf](https://economy-finance.ec.europa.eu/system/files/2023-05/LV_SWD_2023_614_en.pdf)
- European Commission (2023b). Annual report on European SMEs 2022/2023. SME performance review. [https://single-market-economy.ec.europa.eu/smes/sme-strategy/sme-performance-review\\_en](https://single-market-economy.ec.europa.eu/smes/sme-strategy/sme-performance-review_en)
- Gorgels, S., Priem, M., & Blagoeva, T. (2022). Annual report on European SMEs 2021/2022: SMEs and environmental sustainability: Background document. *Publications Office of the European Union*.
- Hayward, J. (2023). Vegetation management: Learning from the wisdom of our ancestors. *TD World*. <https://www.tdworld.com/vegetation-management/article/21270494/vegetation-management-learning-from-the-wisdom-of-our-ancestors>
- Imolore, D. (2023). Indigenous people and the Amazon: An ancient connection. *Fund the Planet*. <https://fundtheplanet.net/amazon-rainforest/indigenous-people-and-the-amazon-an-ancient-connection/>
- Impolevičienė V., Sprūde A. & Mizerova E. (2024). *Sorainen ESG-focused newsletter, March 2024*. <https://www.sorainen.com/publications/sorainen-esg-focused-newsletter-march-2024>



- Kujala, J., Sachs, S., Leinonen, H., Heikkinen, A., & Laude, D. (2022). Stakeholder engagement: Past, present, and future. *Business & Society*, 61(5), 1136-1196. <https://doi.org/10.1177/00076503211066595>
- Lee P., Sims E., Bertham O., Symington H., Bell N., Pfaltzgraff L. & O'Brien M. (2017). Towards a circular economy: Waste management in the EU. *Study of the European Union*.
- Litvaj I., Drbúl M. & Bůžek M. (2023). Sustainability in small and medium enterprises, sustainable development in the slovak republic, and sustainability and quality management in small and medium enterprises. *Sustainability*, 15, 2039. <https://doi.org/10.3390/su15032039>
- Nikadimovs, O. (2023). Corporate social responsibility - Assessment of facilitating and impeding factors for small and medium-sized enterprises in Latvia. *European Integration Studies*, 17, 222-241.
- Permatasari P., & Gunawan J., (2023). Sustainability policies for small medium enterprises: WHO are the actors? *Cleaner and Responsible Consumption*, 9, 100122. <https://doi.org/10.1016/j.clrc.2023.10012>
- Petersons A., & King G. (2009). Corporate social responsibility in Latvia: A benchmark study. *Baltic Journal of Management*, 4, 106-118.
- Sage.com (2023). *Path for growth: Making sustainability reporting work for SMEs*. <https://www.sage.com/en-gb/-/media/files/company/documents/pdf/sustainability-and-society/path-for-growth-cop28-report.pdf>
- Salah, S. (2023). How to build a resilient future using ancient wisdom. *Atlascorps.org*. <https://atlascorps.org/how-to-build-a-resilient-future-using-ancient-wisdom/>
- Setyaningsih, S., Widjojo, R., & Kelle, P. (2024). Challenges and opportunities in sustainability reporting: A focus on small and medium enterprises (SMEs). *Cogent Business & Management*, 11(1). <https://doi.org/10.1080/23311975.2023.2298215>
- World Bank (2019). *SME finance*. <https://www.worldbank.org/en/topic/smefinance>



## Gaurav Prakash. FEMALE FETICIDE IN INDIA

*EKA University of Applied Sciences*

*Master's Study Program "Business Administration"*

*E-mail: Gauravthechef2010@gmail.com*

*Scientific Advisors: Dr. oec., Professor Inga Shina; Dr. oec., Professor Jeļena Titko*

### Abstract

**Research relevance:** In the Indian society, there has been prevalence of the practice of female foeticide and female infanticide. There are various viewpoints regarding the birth of female child and their desire for the male child. In the cases of all the families belonging to rural or urban areas, high status or affluent families or the poverty-stricken families belonging to socio-economic backward sections of the society, all the elderly people possess this viewpoint that male children would effectively contribute in bringing wealth, fame and reputation to the families and female children are considered to be the liabilities. Rural communities believe in marrying off their girls at an early age so that they are able to have more children and the children desired are males. Regarding female children, it is important that every means should be adopted by the parents and other family members to nurture them in a good manner and make provision of all the adequate necessities that are required to live an efficient life. Gender selection and its subsequent female infanticide (FI) remains a big problem for many countries, including India.

**Research goal:** To study the social aspects of female feticide in community of India and in addition of that the psychological effects of it on people especially on women.

**Research methods:** A questionnaire was framed to have a in depth interaction with the respondents, data analysis with chart reflecting the stats of states wise.

**Main findings:** Sex ratio declines very drastically in India from last few area, but not in entire country but only in some of less educated states , but efforts and prevention is took place with very hard rules and regulations by Indian government.

*Keywords: feticide; infanticide; children; gender; women.*

### Introduction

Topicality of the research lies in the fact that sex selective abortions cases have become a significant social phenomenon in several parts of India. It transcends all castes, class and communities and even the North South dichotomy. The girl children become target of attack even before they are born. (Foeticide Research, 2018) According to Srivastava (2014), in a well-known Abortion Centre in Mumbai, after undertaking the sex determination tests, out of the 15,914 abortions performed during 1984-85 almost 100 per cent were those of girl foetuses. Similarly, a survey report of women's centre in Mumbai found that out of 8,000 foetuses aborted in six city hospitals 7,999 foetuses were of girls. It is reported that about 4,000 female babies are aborted in Tamil Nadu (Southern India) every year. Sex determination tests are widely resorted to even in the remotest rural areas. Since most deliveries in rural areas take place at home there is no record of the exact number of births/deaths that take place. Therefore, it is difficult to assess the magnitude of the problem. However, the fact remains that the right

to be born are being denied to the female child. Since all religions treated abortion as immoral, and contrary to divine law, this blanket ban on abortion, resulted in illegal abortions and risking the life of the woman (Srivastava, 2014).

The aim is to study the social aspects of female foeticide in community of India and in addition of that the psychological effects of it on people especially on women. Main method is a questionnaire framed to have a in depth interaction with the respondents, data analysis with chart reflecting the stats of states wise. The hypothesis is important decisions in the family are taken by male members of family that also is in regard to the abortion and other decisions in regard to the children. Results prove the hypothesis as about decision power in family 60% women have said that the important decisions in the family are taken by male members of family, 28% women told that in family decisions are taken by females while 12 % women informed that decisions in family are taken by both male and female members. This shows the male dominating nature of society.

### Literature Review

In India female foeticide is taking place for various factors viz. economic, socio-ritual, and technological (see Fig. 1).

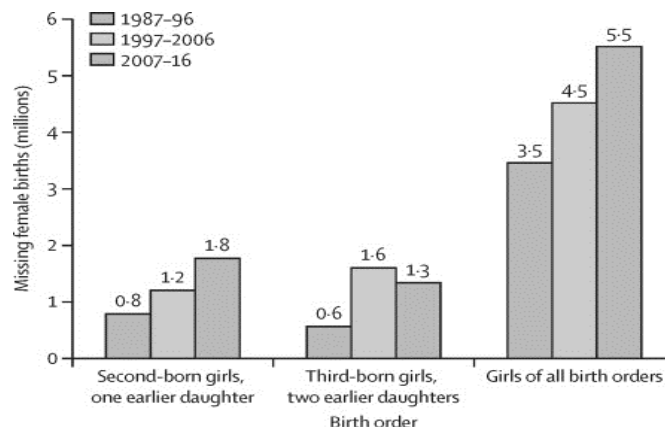

**Fig. 1.** Trends in the absolute number of missing female births in India, 1987–96, 1997–2006, 2007–16 (Source: Sakia et al., 2021)

Economic Factors: the female Foeticide in the 21st century have a great deal to do with capitalist modernity. There are aspects of it lying behind these phenomena. For rural households with landed property there is a clear inverse correlation between the income level and child sex ratio. It is especially evident in south India. Again there is gender based wage level. For the same work females are paid less remuneration. In most cases women enter in the domestic non-paid services which a patriarchal society gives little or no value at all, so they are regarded as liability than assets. (Sharma et al., 2014) Cultural politics of dowry in the Indian society have a lot of answer for this pernicious phenomenon. Since the turn of century the recorded dowry deaths are increasing. Nearly 7- 8000 per year brides are murdered for the lack of full payment of dowry. Nearly 3-5000 brides are committing suicides for dowry. Brides are thought as commodities and the pre marriage and marriage have been described as ‘consumption oriented reproductive journey’. When the reproductive practices make daughters into such economic

burden, the threat of having to amass dowry is motive enough to dispose female commodities. (Sharma et al., 2014) The female foeticide has been commodified. It has started to become a field of accumulation in its own right. Malini Bhattacharya, the member of the national commission for women, admitted that in the era of liberalisation “one has to allow freedom of choice to the service seeker and the freedom to sell by the service provider”. Foeticide may cost one or two month’s earnings, while dowry requires mobilisation of several years’ income. Hence there appears equilibrium between service seeker and provider. UNICEF estimates that the turnover of foeticide industry has now reached 244 million dollar from 77 million dollar in 2006. Those who disapproved of the practice of sex selective abortions but engaged in it against their principles expressed their compulsions and helplessness due to pressures arising out of unhealthy competition in the health care service sector. It was said that if they did not provide abortion care services, some others would have provided them. For these economic reasons females are not desired. (Sharma et al., 2014)

Socio-ritual factors: females are vulnerable to brutalities of the male in the forms of physical, mental and sexual assaults and traumas in the patriarchal societal structure of India. Females are subjugated, condemned, and deprived in sphere of life. Every parent of a girl child is at risk for their daughter in this patriarchal society for the mentioned causes. (Kumar, 2016) Again for the funeral ceremonies of the parents, presence of a son is a must. A man cannot attain moksha (redemption) unless he has a son to light his funeral pyre. In old age the sons will care for them believably. (Kavilpuraidom, 2019) These socio-rituals factors including illiteracy and orthodox society norms lead to crave for a male baby, discarding the females one after another. Female foeticide is a latest trend of long-established gender bias. We are civilized with time and our killing female babes have also been civilized. (Pathak, 2016) The presence of low-cost technologies like ultrasound, have led to sex-based abortion of female fetuses, and an increasingly smaller percentage of girls born each year. (Kavilpuraidom, 2019) Population Policy: Indian family planning policies promote a two-child family and health workers say this often leads to abortion of female foetuses in efforts to have a "complete family" with at least one son. (Sharma et al., 2014)

The immediate impacts of female foeticides the unbalanced sex ratio. The child sex ratio for the age group of 0-6 years has currently 927 per 1000 boys. Punjab has 798 girls, Haryana 819, Delhi 868 and Gujurat 883 per 1000 boys. It is found that there is a gradual decline in the sex ratio from 1901 to 1941 due to infanticides and foeticides and there is a fluctuation in the sex ratio between 1941 and 2001. Here one thing is attracting our attention that though there is substantial increase in the overall sex ratio in India from 1991-2001, there is drastic decline in the child sex ratio (CSR). (MuslimMirror, 2019)

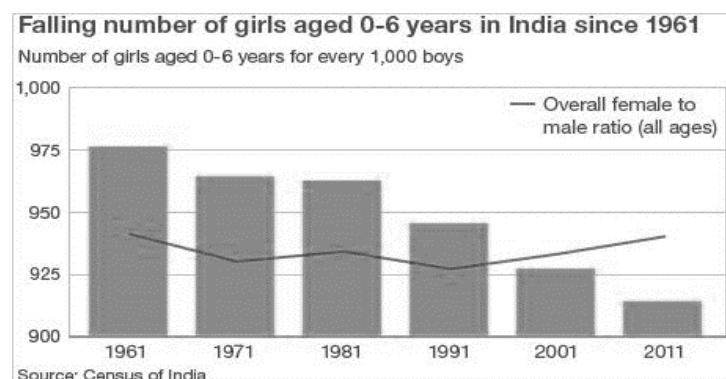

**Fig. 2.** Falling number of girls since 1961 (Source: BBC, 2011)



Female foeticides (see Fig. 2) are common in all states of India irrespective of caste, class, religion, or north south divide. About 5-7 lakh girls a year or 2000 girls a day go missing in India due to female foeticide. During 2000, the highest occurrences of female foeticides are concentrated in Maharashtra (45.1% of India's total foeticides), followed by the states of Madhya Pradesh, Haryana, Rajasthan, Andhra Pradesh (F The overall sex ratio increased from 929 to 933 during 1991 and 2001, but the CSR fall from 945 to 927 during that period (Financialexpress, 2015).

### **Research Methodology**

Data was collected by survey of women belonging to 1000 families by N.S.S. students for the project "Beti Bachav, save girl child" (Naikwade & Phatak, 2013). A survey with the help of structured questionnaires was also carried out of female students of college for study of effects of female foeticide problem. Interviews with doctors, nurses, dais, government hospitals, political people etc. provide significant information about the problem. Secondary data was collected by referring books, Government records, official websites, etc. Help of community leaders, social activists, religious leaders, village 'dais' and traditional healers was sought to make the sampling more realistic and purposeful. During data collection all the possible painstaking efforts were undertaken to take the women activists and respondents in to confidence to win their confidence by ensuring them that the information they provide will be kept secret at every cost and remain confined to the study purpose. (University Hamirpur, 2021)

### **Results**

Women having both boy and girl as child were 59 %, 28% women were with only boys, 11% women were with only girls. However, 2% women were not having any child. (Naikwade & Phatak, 2013) About decision power in family 60% women have said that the important decisions in the family are taken by male members of family, 28% women told that in family decisions are taken by females while 12 % women informed that decisions in family are taken by both male and female members. This shows the male dominating nature of society. Concerning the issue of sex determination before birth, 96% of women responded that they do not feel that sex determination is vital, whereas 4% of women responded that they feel that sex determination is essential. Only 20% of women are aware of the facility or hospital where pre birth sex determination is performed, whereas 80% of women denied having any knowledge of facilities where such practises are widespread. Regarding the origin of the information 35 percent of women learned about the problem of female foeticide from various forms of media such as television, radio, newspapers, and the internet. All of the women interviewed said that they had not participated in pre-sex determination or female foeticide, although 53% of the women stated that they knew other women who had. This demonstrates that even while respondent women are denying that they have participated in female foeticide, they are aware that this kind of problem exists in this location. Even in the most distant parts of the country, people frequently use tests to determine a person's sexual orientation.

In the instance of investigating the factors that lead to female foeticide, numerous facets were looked at. The misconception that the race being passed down from father to son, often known as patrilinealism, is the primary factor. This was cited as the primary reason by 42% of women, followed by the precedence given to son in religious rituals (23%), insecurity of female in society (13%), and dowry (8%). Many parents, if their first kid was a girl, desire their second child to be a boy to ensure the



continuation of their race. As a result, they undergo prenatal testing to determine the baby's gender and choose to terminate the pregnancy if the results indicate that the fetus is female. 4 percent of women had the belief that female foeticide is practised because of the concern that an adult female child may one day be entitled to property rights, and as a result, the practise is carried out. According to the data, another reason for female foeticide is because women are physically weak. This accounts for 2% of all cases. The general population has a poor understanding of the many programmes run by the government for women. A third of women do not have any awareness of these types of initiatives. Respondents are aware that if the problem of female foeticide continues, it would result in a wide variety of societal difficulties as well as insecurity for women. (Naikwade & Phatak, 2013)

### Conclusions

The ineffective implementation of the legislation is evident in India's skewed gender ratio. If it is possible to stop abortion and foeticide of female by legal enforcements on the demand and supply sides, female infants will see the light and breathe the air of the earth. Even if there is no direct female infanticides, indirect infanticides must occur until and unless our conceptions regarding various economic, social, and ritual reasons about the girls are changed.

### References

- BBC (2011). *Where are India's millions of missing girls?* <https://www.bbc.com/news/world-south-asia-13264301>
- Financialexpress. (2015). *Financialexpress*. <https://www.financialexpress.com/in-imaging/pest-le-analysis-ultrasound-market/62498/>
- Foeticide research. (2018). *Female foeticide*. <https://directcurrentmusic.com/storage/female-foeticide-250/>
- Kavilpuraidom, J. (2019). *Report on social issue in India – female foeticide*. <https://jerykavilpuraidom.wordpress.com/2019/03/05/report-on-social-issue-in-india-female-foeticide/>
- Kumar, A. (2016). *There is no he without she “Save the girl child.”* <https://legaldesire.com/there-is-no-he-without-she-save-the-girl-child/>
- MuslimMirror (2019). *Female foeticide and dwindling sex ratio in Jammu and Kashmir*. <https://muslimmirror.com/eng/female-foeticide-and-dwindling-sex-ratio-in-jammu-and-kashmir/>
- Naikwade , P., & Phatak, V. (2013). Study of female foeticide problem with special reference to Sangameshwar tahsil, Maharashtra. *Research Gate*. [https://www.researchgate.net/publication/321333259\\_Study\\_of\\_female\\_foeticide\\_problem\\_with\\_special\\_reference\\_to\\_Sangameshwar\\_tahsil\\_Maharashtra](https://www.researchgate.net/publication/321333259_Study_of_female_foeticide_problem_with_special_reference_to_Sangameshwar_tahsil_Maharashtra)
- Pathak, A. N. (2016). *Female feticides*. <https://www.studocu.com/in/document/svkms-nmims/bachelors-in-law/female-feticides/8759418>
- Sakia, N., Meh, C., Ram, U., Bora, J. K., Mishra, B., Chandra, S., & Jha, P. (2021). Trends in missing females at birth in India from 1981 to 2016: Analyses of 2.1 million birth histories in nationally representative surveys. *Lancet Global Health*, 9(6), e813-e821. [https://doi.org/10.1016/s2214-109x\(21\)00094-2](https://doi.org/10.1016/s2214-109x(21)00094-2)



- Sharma, N., Ram, K., Sharma, A., & Sharma, S. (2014). Where is the bride? progressively declining sex ratio in India: An alarming signal for imbalanced society. *International Journal of Reproduction, Contraception, Obstetrics and Gynecology*, 301–303. <https://doi.org/10.5455/2320-1770.ijrcog20140602>
- Srivastava, P. K. (2014). Female infanticide in 19th-century India: A genocide? *Advances in Historical Studies*, 03(5), 269-284. <https://doi.org/10.4236/ahs.2014.35022>
- University Hamirpur. (2021). *Annual report - CPUH.in*. <http://cpuh.in/academics/32.pdf>





## **Madushani Saumya Jayarathne, Ikkagoda Arachchige. FACTORS AFFECTING STAFF TURNOVER IN THE APPAREL SECTOR IN SRI LANKA**

*EKA University of Applied Sciences  
Master's Study Program "Business Administration"  
E-mail: saumyajayarathne@gmail.com  
Scientific Advisor: Dr.oec., Professor Jeļena Titko*

### **Abstract**

**Research relevance:** The Sri Lankan apparel sector has a major difficulty in the form of excessive workforce turnover, especially in the operational workers category. The current research investigates the critical factors that influence employee turnover among operational employees in this industry, providing insights into challenges crucial to its long-term development and competitiveness.

**Research goal:** This study aims to thoroughly assess the factors that lead to workforce turnover in operational-level categories in the Sri Lankan apparel industry. The research attempts to give significant insights into the fundamental causes of turnover by analysing workplace stress, work-life balance, working conditions, job satisfaction, pay and benefits, cost of living, management support, and career progression possibilities.

**Research methods:** To achieve the research goal, a survey research strategy was employed, involving the distribution of carefully developed structured questionnaires to operational-level workers in major apparel chains in Sri Lanka using stratified sampling technique. The collected data were processed using SPSS software, incorporating descriptive statistics, correlation analysis, and multiple regression analysis to derive meaningful and statistically significant conclusions for the study.

**Main findings:** The research reveals that unsatisfactory compensation and benefits, job dissatisfaction, and workplace stress were the main factors leading to turnover intentions among operational workers in the apparel sector in Sri Lanka. While these variables have a considerable effect, poor working conditions and limited career progression possibilities, cost of living and limited work-life balance also indicated a significant effect on employee turnover. These results emphasize the need for industry participants to adopt a holistic strategy for dealing with these difficulties to enhance employee retention in the industry.

*Keywords: employee turnover; pay & benefits; workplace stress; job dissatisfaction; work-life balance.*

### **Introduction**

As discussed deeply in the above background information relating to this study, The turnover of personnel in the global as well as Sri Lankan the garment industry is impacted by a multitude of interrelated variables, including workplace stress, work-life balance, working conditions, job satisfaction, compensation and benefits, cost of living, management support, and career advancement opportunities. However, there is a lack of exact knowledge relating to what are the exact impact of these variables on the determination of employee turnover levels as well as which factors may influence more and which factors have fewer influence on the determination of employee turnover levels in the apparel



industry in Sri Lanka. Thus, it is essential to thoroughly analyse these factors in order to develop comprehensive plans that will improve staff retention and promote the long-term viability of the organization. Organizations may develop a resilient workforce that can adapt to changing market dynamics and industry problems by addressing the underlying reasons for employee turnover and executing specific interventions.

The Object of this research is employees representing the private companies in the apparel industry in Sri Lanka. The Subject of this research is factors affecting employee turnover intention in apparel industry in Sri Lanka. Aim of the research is to identify the factors affect staff turnover in apparel industry of Sri Lanka. For the investigation of the reserch data collection method used was online survey. For analyzing the result SPSS was used in the quantitative part of research.

the results of this research have important consequences for organizations that work in the garment sector in Sri Lanka. Organizations may proactively address turnover by identifying the main Implementing strategies focused on boosting work-life balance, increasing job satisfaction, and offering sufficient support and resources may assist organizations in cultivating a favorable work environment that promotes employee retention.

### **Literature Review**

Staff turnover is a key notion that refers to the rate at which employees leave an organization and are therefore replaced by new recruits (Codling et al., 2023). This rate is referred to as the turnover rate within the field of human resource management. There may have a number of factors that contribute to the formation of the level of employee turnover in a specific organizational context, and thus, this issue is regarded as being complicated. These factors include workplace contentment, organizational culture, compensation and perks, opportunities for professional advancement, and external market conditions. In the process of analyzing employee turnover, it is possible to take into account a variety of distinct theoretical orientations (Kanchana & Jayathilaka, 2023; Mamun & Hasan, 2017). Employee turnover is regarded as a regular aspect or issue of the dynamics of an organization, representing the ebb and flow of workers within a workforce (Vasantham & Aithal, 2022). This is the first point to consider. Aspirations for professional progress, relocation, retirement, or discontent with their existing responsibilities are some of the reasons why employees may decide to quit their jobs. When seen from this angle, employee turnover is unavoidable and may even be advantageous for businesses since it enables the introduction of new individuals with fresh ideas and new skills (Nguyen & Shao, 2019).

Additionally, the rate of staff turnover may be seen as an indication that there are underlying issues to be found inside a business. There are a number of structural concerns that may be suggested by high turnover rates. Some examples of these issues include inadequate management approaches, poor employee morale, inadequate compensation, and a lack of opportunities for professional progress (Taborosi et al., 2023). When seen in this context, staff turnover serves as a warning sign that requires attention and action in order to eradicate the underlying causes of the problem and improve the effectiveness of the company.

The garment export business in Sri Lanka has emerged as one of the most important areas of the country's economy as a result of the enormous increase that it has seen over the course of the last four decades. After a year-on-year rise in exports of 22.93 percent over the previous year, the value of the sector reached \$5.42 billion in 2021. This was the result of the industry's continued growth (SilkPorts, 2022). It is the goal of the garment industry to attain exports worth \$8 billion by the year 2025. This is due to the fact that the present economic crisis has made it more difficult for the business to get inputs.

Increasing investments in local supply chains will be the means by which this objective will be achieved. As an additional point of interest, the clothing industry is now the most significant export sector in the country. In addition to being responsible for around 33 percent of the manufacturing employment in the nation, it is responsible for approximately 44 percent of the total exports (SilkPorts, 2022).

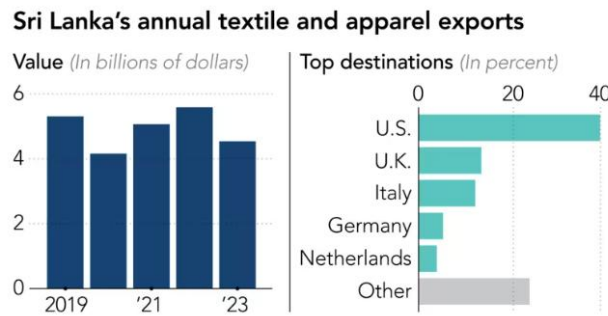

**Fig. 1.** Statistics of apparel industry in Sri Lanka (Source: JAAFS, 2023)

The graph that provided above demonstrates that the value of Sri Lanka's annual textile and garment exports has been on an increasing trend since 2019. This pattern has been seen since 2019. During the year 2019, the total value of exports was exceeded five billion dollars. By the time the year 2023, the exporting valued have indicated some declining trend indicating the value approximately \$4.86 billion in Export Revenue in 2023 (Marwaan, 2024).

When it comes to assessing the share of exports the major clients associated with Sri Lankan apparel industry are displayed in the above figure, in the year 2021, the United States of America accounted for 38 percent of Sri Lanka's total textile and garment exports, making it the most significant destination for these products in the country. Additionally, the United Kingdom (12.4%), Italy (7.79%), Germany (6.05%), and the Netherlands (4.54%) are among the most popular destinations.

According to the Sri Lanka Export Development Board (EDB), the textile and clothing industry is the most significant export sector in the country. In the year 2023, the textile and clothing industry was responsible for 41.82 percent of the entire money that the country got from exports. The Export Development Board (EDB) has set a target of attaining a total of eight billion dollars in revenue from exports from the industry by the year 2025. As discussed by Sri Lanka Economic Growth (2024), there could identified some emerging positive trends aligned with the workforce of the apparel workers in the industry in Sri Lanka.

### Research Methodology

The research method was a survey. A structured questionnaire was distributed among operational-level workers employed in selected major apparel chains in Sri Lanka. Five major apparel manufacturing firms were selected for the study collectively employed approximately 6000 employees. These firms were included Mas Intimates Pvt Ltd, Omega Line Ltd, Brandix Apparel Pvt Ltd, Hirdaramani International Exports Pvt Ltd and Jay Jay Mills Lanka Pvt Ltd The sample size of 361 was chosen based on the guidance provided through the use of Morgan table from a population of approximately 6000 operational-level workers employed across five major apparel manufacturing firms in Sri Lanka. The

sample profile of 361 operational-level workers were developed as the following table presented using stratified sampling technique.

**Table 1.** Sample Profile (Source: Created by the authors)

Firm	Operational Worker Population	Stratified Random Sampling Sample Size
Firm A	1900	Sample 115 individuals
Firm B	1300	Sample 78 individuals
Firm C	1000	Sample 60 individuals
Firm D	1200	Sample 72 individuals
Firm E	600	Sample 36 individuals
Total	6000	361

Data collection of this study was conducted based on two categories. The secondary data was assessed in order to conduct the literature review part and identifying an assessing the market dynamics relating to the garment industry in Sri Lanka based on the published data in websites, industry reports and journal articles. However, the major contribution was done by the primary data which were collected by distributing a structured survey within the sample population chosen for this study.

## Results

The reliability of the study instrument was tested by the Cronbachs Alpha test (see Table 2).

**Table 2.** Cronbach’s Alpha test results (Source: Created by the authors)

Variable	Dimension	Cronbach’s Alpha	Reliability	
Independent variables	Factors Affecting Staff Turnover	Workplace stress	0.847	Reliable
		Low work-life balance	0.888	Reliable
		Job dissatisfaction	0.792	Reliable
		Poor working conditions	0.764	Reliable
		Pay & Benefits	0.800	Reliable
		Poor management support	0.836	Reliable
		Low career growth	0.815	Reliable
		High cost of living	0.851	Reliable
Dependent variables	Employee Turnover Intention		0.835	Reliable

All of variables surpass the commonly accepted threshold of 0.7 for reliability. This indicates that the independent variables are reliable. Based on this, it seems that the questions of the questionnaire within each dimension assess the target construct in a consistent manner, which indicates that the questionnaire is reliable and consistent internally According to the findings, factors such as high cost of living, low

career growth, low work-life balance, job dissatisfaction, poor working conditions, pay and benefits, poor management support, and high levels of stress in the workplace all have a significant impact on employee turnover. This is demonstrated by standardized coefficients and p-values that are lower than 0.05. As a result, all hypotheses are accepted, which indicates that these variables play significant roles in determining the turnover rates that occur within the business. The significance of tackling these challenges in order to promote staff retention and organizational stability is shown by these results.

**Table 3.** Hypothesis Testing Summary (Source: Created by the authors)

Hypothesis		Simple Lenier Regression Result		Multiple Lenier Regression Results		Decision (p < 0.05)
		Standardized Coefficients	Sig. (2Tailed)	Standardized Coefficients	Sig. (2Tailed)	H <sub>A1</sub>
H <sub>A1</sub>	Workplace stress has significantly impact on employee turnover in apparel industry in Sri Lanka.	0.736	.000	0.233	.000	Accepted
H <sub>A2</sub>	Low work-life balance has significantly impact on employee turnover in apparel industry in Sri Lanka	0.477	.000	.103	.000	Accepted
H <sub>A3</sub>	Job Dissatisfaction has a significant impact on employee turnover in apparel industry in Sri Lanka.	.753	.000	.184	.000	Accepted
H <sub>A4</sub>	Poor Working Conditions has a significant impact on employee turnover in apparel industry in Sri Lanka.	.668	.000	.065	.026	Accepted
H <sub>A5</sub>	Pay & Benefits has a significant impact on employee turnover in apparel industry in Sri Lanka.	.776	.000	.247	.000	Accepted
H <sub>A6</sub>	Poor Management Support has a significant impact on employee turnover in apparel industry in Sri Lanka.	.684	.000	.105	.000	Accepted
H <sub>A7</sub>	Low Career Growth has a significant impact on employee turnover in apparel industry in Sri Lanka.	.201	.000	.061	.005	Accepted
H <sub>A8</sub>	High Cost of Living has a significant impact on employee turnover in apparel industry in Sri Lanka.	.744	.000	.233	.000	Accepted

According to the findings, factors such as high cost of living, low career growth, low work-life balance, job dissatisfaction, poor working conditions, pay and benefits, poor management support, and high levels of stress in the workplace all have a significant impact on employee turnover. This is demonstrated

by standardized coefficients and p-values that are lower than 0.05. As a result, all hypotheses are accepted, which indicates that these variables play significant roles in determining the turnover rates that occur within the business. The significance of tackling these challenges in order to promote staff retention and organizational stability is shown by these results.

## Conclusions

Based on the extensive literature review, survey and research work done, the authors of this paper made the following conclusions:

- The goal of the research to identify factors affect staff turnover has been achieved as it shows on the table 56. Eight factors have been tested. Four of them turned out to be highly significant.
- Poor Pay & Benefits has a significant positive impact on employee turnover in apparel industry in Sri Lanka and this was the most influential one in this study.

According to the statistical analyses conducted in the study poor levels of pay and benefits shown the most influential aspect compared with other variables.

- Workplace stress has a significant impact on employee turnover in apparel industry in Sri Lanka.

According to the statistical analyses conducted in the study and literature review conducted this finding was true and significant.

- Low Work-life Balance has a significant positive impact on employee turnover in apparel industry in Sri Lanka.

According to the statistical analyses conducted in the study and literature review conducted this finding was true and significant.

- Job Dissatisfaction has a significant positive impact on employee turnover in apparel industry in Sri Lanka.

According to the statistical analyses conducted in the study and literature review conducted this finding was true and significant.

- Poor Working Conditions has a significant positive impact on employee turnover in apparel industry in Sri Lanka.

According to the statistical analyses conducted in the study and literature review conducted this finding was true and significant.

- Poor Management Support has a significant positive impact on employee turnover in apparel industry in Sri Lanka.

According to the statistical analyses conducted in the study and literature review conducted this finding was true and significant.

- Low Career Growth has a significant positive impact on employee turnover in apparel industry in Sri Lanka.

According to the statistical analyses conducted in the study and literature review conducted this finding was true and significant.

- High Cost of Living has a significant positive impact on employee turnover in apparel industry in Sri Lanka.
- Employees in the garment industry in Sri Lanka with a high intention of leaving.

According to the findings of the survey, a significant number of workers in the garment sector in Sri Lanka had the aim of quitting their employment. This conclusion is derived from the significant correlations that were discovered between a variety of factors, including but not limited to: workplace stress, low work-life balance, job dissatisfaction, poor working conditions, inadequate pay and benefits, insufficient management support, limited career growth opportunities, and the high cost of living. All of these factors contribute to employees' intentions to leave their current position. This suggests that there is a serious problem within the sector that has to be addressed in order to get higher rates of employee retention and to promote organizational stability.

### References

- Ahmed, S., Hasanuzzaman, M., Chowdhury, M. S., Sheikh, M. E., & Munir, S. (2018). A survey on the factors affecting employee turnover in the readymade garments of Bangladesh. *Global Journal of Researches in Engineering*, 18, 47-51.
- Bodla, M., & Hameed, A. (2009). Factors affecting employee turnover intentions: Empirical evidence from textile sector of Pakistan. *International Journal of Knowledge, Culture and Change Management*, 9, 55-66.
- Chamini, H., & Randeni, R. (2016). Examine the relationship between organizational factors and employee turnover in apparel industry in Sri Lanka. *Journal of Business Studies*, 3(1), 14. <https://doi.org/10.4038/jbs.v3i1.28>
- Chandrasekara, P. G. R. B. (2020). Factors and their influence on employee retention of the apparel sector employees in Anuradhapura district. *International Journal of Scientific and Research Publications (IJSRP)*, 10, 543-558. <https://doi.org/10.29322/IJSRP.10.07.2020.p10358>
- Codling, S., Pinnock, J., Barrett, E., Gayle, S., Stephenson, N., Sibblies, N., & Sinclair-Maragh, G. (2023). Factors contributing to staff turnover in the hotel industry: A literature review. *IntechOpen eBooks*. <https://doi.org/10.5772/intechopen.107025>



## **Ambuja Bangalore Srinivasa. GUIDELINES FOR DEVELOPMENT OF STRATEGY FOR GLOBAL COMPETITIVE ADVANTAGE OF LATVIAN COSMETIC COMPANIES**

*EKA University of Applied Sciences  
Master's Study Program "Business Administration"  
E-mail: ambuja.oct16@gmail.com  
Scientific Advisor: Dr.oec., Professor Jeļena Titko*

### **Abstract**

**Research relevance:** As per Statista (2024) consumption value of cosmetics and personal care in Latvia was 168 million Euros (as of 2021). Based on Lursoft data, there are 164 cosmetic companies in Latvia as of 2024.

**Research goal:** Research goal is to create Guidelines For Development Of Strategy For Global Competitive Advantage Of Latvian Cosmetic Companies.

**Research methods:** To achieve the research goal survey among Latvian citizens (consumers of Latvian cosmetic brands) was conducted. Besides, analysis of development strategies of Latvian and other European cosmetic companies was studied. Also, media monitoring was also done by investigating web pages on Instagram of some local consumers.

**Main findings:** Based on research results quality of a product is the main factor to be taken into notice by cosmetic company with reasonable pricing. Quality cannot be compromised in order to have competitive pricing in market. Maintaining online platform is very crucial for cosmetic industry, continuous updates of their new products line and live reviews is very important. Any local born company intending to go global should launch their global market within first 6 months and based on analysis guidelines was created.

*Keywords: global competitive advantage; brand value; sustainable brand development.*

### **Introduction**

In the past decade or two, global presence and branding has become a very important factor for any company in the market. With the advancement of technology, internet access and transportation, the world has become even more connected than it has ever been.

The rise of social media and the influence of celebrity culture have undeniably propelled the cosmetic industry into the spotlight. With platforms like Instagram and YouTube showcasing the latest beauty trends and products, consumers are more exposed and aware of cosmetic options than ever before. This heightened visibility has led to the industry's expansion and prominence in the market. As per the data published by (Statista, 2024) cosmetic market is constantly growing, and consumption value is 185 million Euros for Latvia. The forecast for the cosmetic consumption industry in 2028 is expected to be 128 billion US dollars.





The aim of the study was to identify competitive advantage factors and create guidelines for development of strategy for global competitive advantage of Latvian cosmetic market from the survey.

Research tasks that will be carried out for this study are:

- Explore the concept of global competitive advantage by means of bibliometric analysis.
- Analyse the development trends in Latvian cosmetic markets.
- Analyse the development strategy of Latvian cosmetic brands.
- Create a questionnaire to evaluate perception of Latvian cosmetic brands.
- Conduct survey among Latvian citizens.
- Describe elements of strategy for global competitive advantage for Latvian cosmetic companies.

Data collection methods used in the research paper are literature analysis, survey, media monitoring. Data were analysed using processing methods such as bibliometric analysis, frequency analysis, graphical analysis.

In the part “Results”, the author of the research paper analysed the data received from the survey, using frequency analysis, graphical analysis, and media monitoring. Finally, the guidelines were formulated which was the practical importance of this study will help the practical business world of cosmetic industries to follow a few guidelines to remain in the global competitiveness of the sector.

## **Literature Review**

### **Core of Business Competitiveness**

Competitiveness is a widespread and globally accepted term, yet there is no single accepted definition for it. Definitions have been tailored based on the context and level it is been used in. According to the European Community (Bizottsag, 1999), the concept of competitiveness is linked to the ability of businesses, industries, regions, nations and transnational regions to generate, while being exposed to international competition, relatively high income and employment levels. The European Management Forum defines competitiveness as the immediate and future ability of, and opportunity for, businessmen to design, produce and market goods worldwide whose price and non-price qualities form a more attractive pack than those of foreign and domestic competitors (Buckley et al., 1988).

Porter (1985) defined as competitiveness is a function of dynamic progressiveness, innovation and a capability to change and improve. The EY-Parthenon comparative leadership methodology assesses a value chain by global market leadership, business leadership and innovation leadership, with scores based on current strength and the potential for future strength in these areas. Bodies governing industrial policy and competition may consider focusing their agendas on businesses value chains that are competitive or not to address global competitiveness in any industry of interest. (Reasons et al., 2022). Summary of definitions are available in Siudek and Zawajska (2014, 94), where “competitiveness is a set of characteristics of one object with respect to comparable objects (benchmarks) on the market”.

### **Cosmetic Market Overview in Europe**

The cosmetic market in Europe is one of the largest and very diverse in the world. Europe shares a significant share of global cosmetic market with major countries like Germany, France, Italy, UK as

their top consumers (see Fig.1). With the rising incomes and lifestyle changes, there has been a significant increase in wellbeing and grooming.

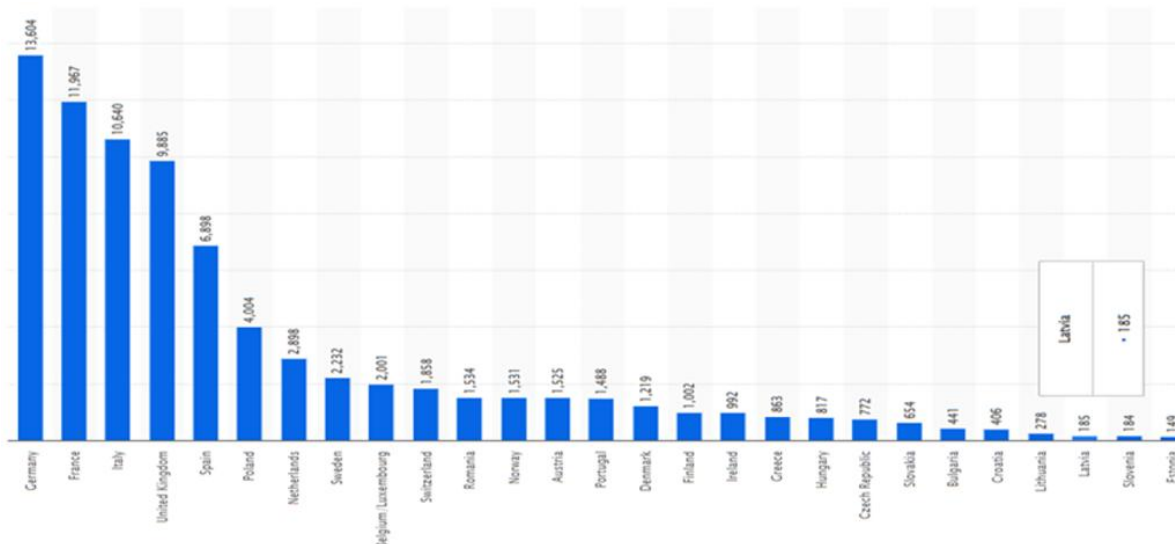

**Fig 1.** Consumption value of cosmetics and personal care in Europe as of 2021 in million Euros (Source: Adapted from Statista, 2024)

### Cosmetic Market Overview in Latvia

The total cosmetic consumption of Latvia is 185 billion Euros as of 2021 (Statista, 2024) which is approximately 0.5085% of Latvia’s GDP. The annual turnover of Douglas Group is 33.7 billion Euros as per (Lursoft annual reports, 2024). Douglas is in the top 100 company list which had huge turnover in the year 2023. The Douglas Group is not a Latvian manufacturer but is currently Europe's largest lifestyle retailer with more than 1800 specialty stores across Europe. Douglas store is a sophisticated retail chain for all reputed cosmetic brands like Chanel, Dior, etc. which are global brands and also has local Latvian brand products Madara Cosmetics. This proves that with proper strategy, vision and mission, demand for cosmetic products can be increased globally. Proper terms of partnership and distribution can increase the sales of the products.

As per the Lursoft data there are 164 cosmetic companies recorded in Latvia. But out of which 77 companies are still present in records, 47 are liquidated, 40 are closed. Out of 77 present records only 45 of them have Lursoft ratings, which means they have active records which their financial data and other set of data updated.

As per author’s view companies globally adopt few different strategies for maintaining competitive advantages, but few important strategies are as listed below:

- Leadership and Cost strategy: A company which aims to become the lowest-cost producer in the industry by leveraging economies of scale. This allows the company to have a competitive advantage by offering lower prices or higher quality products while maintaining profitability, this strategy favors companies with larger market share.
- Product differentiation strategy: Firms which focus to serve particular needs of consumers follow this strategy. For example, needs like comfort, aesthetics and performance.

- Niche strategy: Few companies especially smaller ones focus on specializing in niche market to capture and make their strong mark in those markets (Kotabe & Helsen, 2011).

## Research Methodology

### Cosmetic Companies have potential for Global Competitiveness

With the advancement of technology, internet access and transportation, the world has become more connected. The rise in usage of social media platforms and the rising social media influencers across the world has given a golden opportunity for cosmetic industry to spread globally.

Consistent with LLP (2016), cosmetic industry market is segmented and it will be an useful factor for a cosmetic company to understand this segmentation for their sales strategy. Study shows that the global cosmetics market is a significant segment, driven by the widespread use of skin care and hair care products across men and women. The market is further segmented by distribution channels, including retail and online sales, with retail mode encompassing various outlets such as supermarkets, general department stores, drugstores, pharmacies, and others. Additionally, the market is also categorized by geography, covering regions like North America, Europe, Asia-Pacific, Latin America, Middle East, and Africa (see Table 1).

**Table 1:** Factors affecting Business competitiveness in cosmetic industry across countries (Source: Created by the author)

Source	Title	Country	Strategy Factors
Kumudhini, N. & Kumaran, S. S. (2020)	Factors Influencing on Purchase Intention towards Organic and Natural Cosmetics	Sri Lanka	Creating a positive attitude toward buying organic cosmetics products attracts more consumers
Zhang, J., & Zhou, M. (2019)	Factors influencing consumer purchasing behavior of natural cosmetics: A qualitative study in Uppsala, Sweden	Sweden	Perceived behavioral control, attitude and subjective norms.
Brückel, S., & Schneider, S. (2019)	Factors Influencing Consumer Behavior to Purchase Sustainable Cosmetic Products in a German Context	Germany	Sustainable consumption often results from planned decisions rather than hedonic reasons
Kumar, S., Massie, C., & Dumonceaux, M. D. (2006).	Comparative innovative business strategies of major players in cosmetic industry	United States of America	Unique Product line and selling methods captures the market well.

An extensive study by (Feng, 2017), illustrate how some Latvian brands successfully enter to Chinese market. The study shows that top few Latvian brands consumed in China are STENDERS with 46.12 million Euro turnover as of 2016, followed by Amber jewellery, Riga Black Balsams, Laima chocolates. A few suggested strategies by author to enter Chinese market are Branding, Discount season sales, Fancy packaging, Adaption with the local culture.

### Strategy of MADARA cosmetics – as illustrated by its CEO

- The first step towards entering global markets: Choosing the right distributor
- The second step: Absolute control over quality
- The third step: Acquiring and utilizing money
- Other steps: Ambition, common aims and clearly defined targets

“Ambitious and clearly defined targets are further keys to our success in global markets,” says Lotte. In this regard the CEO of MADARA Cosmetics emphasizes the importance of aiming high from the very beginning. “In our case the big target was a global orientation; it would not be hard to set and achieve the target of being the best in Latvia, but would we be satisfied once this aim is achieved? I don’t think so.” (Sauka, 2015).

### Springboard Expansion Strategy for Born Global Firms

An extensive study by Sauka (2015) suggests that a company should not operate in a domestic market longer than for six months.



**Fig. 2.** Springboard Expansion Strategy for Born Global Firms (Source: Sauka, 2015)

Meanwhile, suggests to start selecting the first strategic foreign market that would allow it to meet economies of scale and to acquire the needed experience for further successful growth. It is also important to consider that, especially with limited resources that can be invested in international expansion, entering global markets can take time - that is another reason to start working on this from the first day of operations. The first market could thus act as a “spring board” as in Fig. 2 that allows to achieve more rapid growth and accumulate needed financial resources in order to continue the growth in several host markets simultaneously.

### Development of Research Instrument

The questionnaire was used as a tool for this study, a questionnaire was formulated and distributed among Latvian customers, both men and women. The questionnaire has been developed into two sections: Section A - Respondent profile, Section B - Factors for Global Competitive advantage of Cosmetic companies. Section A has 08 questions [Gender, Age, Education level, Occupation status, Average income per month, Family status, Where do you usually purchase your cosmetics?, What is your average expenditure on cosmetic products per month?]. Section B has Factors that are important for global competitive advantage of cosmetic company. Here 19 statements are included in one question and they are given Likert scales.

Gender of the respondent was asked to understand if men also invested more in cosmetics as much as women does. The age was a consideration to see if the cosmetics are used more by middle age, adults, or teenagers. The questionnaire was designed to mark 18 to 25 years of age and 26 to 45 years of age and 45 to 64 years of age and above 64. Educational level was included in the questions with options Up to Ordinary Level Education, Up to Advanced Level Education, Degree/ Diploma Level Education, Post Graduate Level Education.

The question of average salary was important to understand if the salary earned was directly proportionate to the money spent on cosmetics every month. The basic salary as per government regulations for a professional job and for foreigners is 1250 gross as of year 2024, few jobs might differ between 1250 to 2000 Euros based on type of industry or skill. Few skilled labor jobs have salary range of 800 to 1250 Euros, individuals with more experience or experts earn more than 2000 Euros in Latvian market, hence, the range were as above in the questionnaire. A question on family status was asked in section A of the questionnaire to understand if singles spent more on cosmetics compared to married individuals.

Finally, a question about personal monthly expenditure on cosmetics was asked in the personal profile section of questionnaire to understand how much an individual spent monthly on their cosmetic products. As per Latvian market and pricing 50 Euro was determined to be the minimum expenditure on cosmetics on a monthly basis, even if an individual spent only basic products 50 Euro was a good amount to cover those products. Middle range of expenditure was found to be 50 to 100 Euros and higher up from 100 to 150 Euros to buy high end products and also a expenditure category for those who spend a lot and experiment with their products as more than 200 Euros.

### Testing of Research Instrument

A total of 101 responses were collected at the end of the survey, out of which female respondent's percentage is 68.3% and male respondent's percentage is 31.7%.

To test the quality of the questionnaire, a reliability analysis was used, specifically the Test for internal consistency with calculation of Cronbach's alpha. The value of Cronbach alpha for the whole measurement scale (19 factors) = 0.894 points to the excellent internal consistency. To analyse the instrument in details, the Item-total correlation analysis was performed (see Table 2). The 19 factors of the section B questionnaire are shown in Table 2.

**Table 2.** Test for internal consistency: Item-total correlation analysis (Source: Author's calculation in SPSS)

Factor	Factor Code	Corrected Item-Total Correlation	Cronbach's Alpha if Item Deleted
Branding	9.1	.575	.887
Marketing and advertising strategies	9.2	.630	.885
Geographical diversification of production and distribution	9.3	.568	.887
Research and development (R&D)	9.4	.705	.883
Sustainable and environmentally friendly practice	9.5	.513	.889
Loyalty and brand recognition	9.6	.584	.887
Quality of ingredients and product formulation	9.7	.495	.890

Pricing	9.8	.115	.897
Ability to adapt to cultural differences	9.9	.580	.887
Design of the package as an important factor	9.10	.605	.886
Online availability of products as an important factor	9.11	.605	.886
Cruelty free product	9.12	.333	.894
Vegan product	9.13	.475	.890
Good reviews	9.14	.576	.887
Recommendations by current customer	9.15	.584	.887
Brand created by a celebrity	9.16	.443	.892
Brand used by a celebrity	9.17	.415	.892
Having wide variety of options (like shades, texture, etc.) in single brand	9.18	.444	.891
Advice from instore consultant	9.19	.645	.885

There are no items (factors) that should be removed from the scale according to the results summarized in the last column of Table 2 “Cronbach's Alpha if Item Deleted”. Therefore, all the factors evaluated by respondents will be analysed.

### Results

Results of the study were achieved based on three different steps, survey questionnaire, analysis of data using frequency analysis and media monitoring. Finally, a step by step guidelines was created based on analysis. Survey data revealed that majority of respondents (40) earned more than 2000 Euros and 31 of them earned between 1250 to 2000 Euros per month as in Fig. 3. Based on analysis of data it was found that consumers’ expenditure is very strongly correlated with monthly earnings.

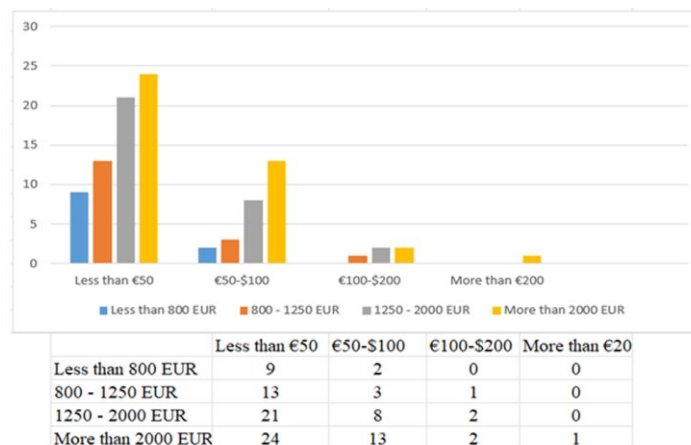

**Fig. 3.** Frequency of expenditure on cosmetics based on average monthly income (in numbers)  
(Source: Created by the author)

The top 5 important factors which mattered to customer as per survey results were Quality of ingredients with 70 responses, Pricing with 59 responses, Good reviews with 54 responses, Sustainable and environmental friendly with 51 responses, Cruelty free with 49 responses.

### Latvian Cosmetic Company Media Monitoring

The cosmetic company ranking is available in Table 3.

**Table 3.** Cosmetic Company Rankings by famous Websites (Source: Created by the author)

Company	Ranking	Source	Webpage	Year of Establishment
Madara	47	Top101	<a href="https://top101.lv/en/company/237/?ref=top">https://top101.lv/en/company/237/?ref=top</a>	2006
Madara cosmetics	2	Latvia travel	<a href="https://www.latvia.travel/en/latvian-products-online-stores-feel-vibe-latvia">https://www.latvia.travel/en/latvian-products-online-stores-feel-vibe-latvia</a>	2006
Douglas	98	Baltic brands	<a href="https://balticbrands.eu/en/rankings/mostloved/baltic/4">https://balticbrands.eu/en/rankings/mostloved/baltic/4</a>	2009
Douglas	72	Top101	<a href="https://top101.lv/en/company/296/?ref=top">https://top101.lv/en/company/296/?ref=top</a>	2009
Douglas	10	Top darbavejs	<a href="https://www.topdarbadevejs.lv/en/year/2022/">https://www.topdarbadevejs.lv/en/year/2022/</a>	2009
Stenders cosmetics	9	Latvia travel	<a href="https://www.latvia.travel/en/latvian-products-online-stores-feel-vibe-latvia">https://www.latvia.travel/en/latvian-products-online-stores-feel-vibe-latvia</a>	2001

Madara cosmetics and Stenders has maintained a good social media presence along with updated data of their financial status on database websites, hence they have a good ranking by other social media websites which is important for a cosmetic company.

### Strategic Guidelines for Competitive Advantage of Latvian Cosmetic Market

After literature review and data analysis, the author determined a few steps for the guidelines, which will serve a pivotal purpose for cosmetic company to enter global market and sustain the global competition (see Fig.4).

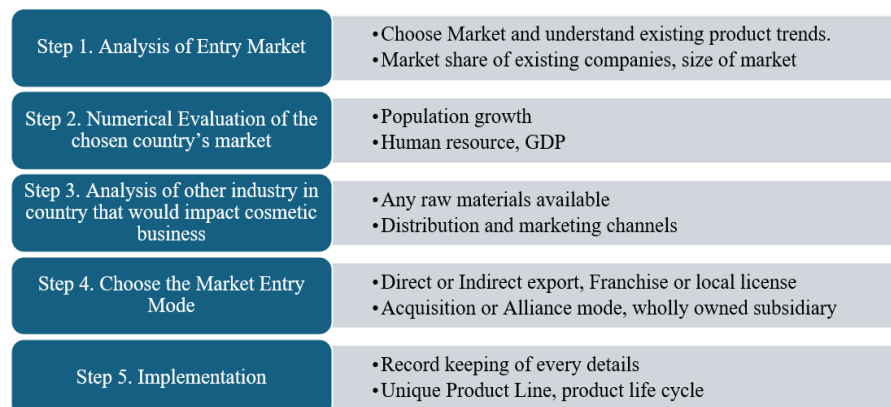

**Fig. 4.** Strategic Guidelines for Competitive Advantage for the Latvian Cosmetic Market (Source: Created by the author)

There are 5 main steps developed by author, which has few sub steps involved. Step 1 is to analyse the entry market or country, to understand fully what exists there already. Step 2 is evaluation of the chosen market, analyse their GDP growth, population growth and forecast opportunities. Step 3 is to analyse if any other market would impact the cosmetic business in that country. Step 4 is to choose the entry mode of market, if the company want to invest directly or not, if they want to have a franchise or local license, if they want wholly owned subsidiaries. The last step is implementing itself, maintain their records correctly, research on new product lines, etc.

### Conclusions

Based on the study and analysis of data, the following conclusions were drawn by the author and a few recommendations were made:

- Quality is the most important factor to be maintained by cosmetic industry with reasonable pricing.
- Good reviews is the 2nd most important factor which means an online presence of the product plays an important role where customers can see it at any given time.
- Due to rising consciousness about global warming, a product being sustainable and eco friendly plays major role in keeping up their sales.

Few recommendations were made for researchers and cosmetic companies:

- Researchers should include multiple options while asking customers any questions.
- Maintain all track records online.
- Cosmetic companies should strongly consider developing e-commerce stores in all export countries.
- Latvia has very less local manufacturing industries in multiple sectors, it needs a framework to make its own local companies competitive.

### References

Bizottság, E. (1999). Sixth periodic report on the social and economic situation and development of regions in the European Union. *European Commission, Office for Official Publications of the European Communities, Luxembourg*, 242.

Brückel, S., & Schneider, S. (2019). Factors influencing consumer behavior to purchase sustainable cosmetic products in a German context. *Regional and Business Studies*, 11(2), 13-24.

Buckley, P. J., Pass, C. L., Prescott, K. (1988). Measures of International Competitiveness: A critical Survey. *Journal of Marketing Management*, 4(2), 175-200.

Feng, H. (2017). An Exploratory Analysis of Latvian brands competitiveness in China. *European Integration Studies*, 11, 174-185. <https://doi.org/10.5755/j01.eis.0.11.18913>

Kotabe, M. M., & Helsen, K. (2022). *Global marketing management*. John Wiley & Sons.





- Kumar, S., Massie, C., & Dumonceaux, M. D. (2006). Comparative innovative business strategies of major players in cosmetic industry. *Industrial Management & Data Systems*, 106(3), 285-306.
- Kumudhini, N. & Kumaran, S. S. (2020). Factors Influencing on Purchase Intention towards Organic and Natural Cosmetics. *The Conference Proceedings of 11th International on Business & Information ICBI, University of Kelaniya, Sri Lanka*, 581-595.
- LLP, A. A. (2016). *World Cosmetics Market - Opportunities and Forecasts, 2014-2022*. <https://www.researchandmarkets.com/reports/3275915/world-cosmetics-market-opportunities-and>
- Lursoft annual reports (2024). *Annual Reports*. <https://statistika.lursoft.lv/en/statistics/annual-reports/with-the-biggest-annual-turnover/district/riga/2023/#page3>
- Porter M.E. (1985). *Competitive Advantage*. The Free Press/Macmillan
- Reasons.T, Lytle. R, & Boorstein. S (2022). EY-Parthenon competitiveness framework for governments. *EY Parthenon*. [https://www.ey.com/en\\_us/insights/government-public-sector/ey-parthenon-competitiveness-framework-for-governments](https://www.ey.com/en_us/insights/government-public-sector/ey-parthenon-competitiveness-framework-for-governments)
- Sauka. A. (2015). Cases studies of Latvian entrepreneurs: For lecturers, scientists and practitioners. *Research Gate*. [https://www.researchgate.net/publication/274699742\\_Cases\\_studies\\_of\\_Latvian\\_Entrepreneurs\\_for\\_lecturers\\_scientists\\_and\\_practitioners](https://www.researchgate.net/publication/274699742_Cases_studies_of_Latvian_Entrepreneurs_for_lecturers_scientists_and_practitioners)
- Siudek, T., & Zawajska, A. (2014). Competitiveness in the economic concepts, theories and empirical research. *Acta Scientiarum Polonorum Oeconomia*, 13(1), 91-108.
- Statista (2024). *Cosmetic & Personal care Report*. <https://www.statista.com/statistics/382100/european-cosmetics-market-volume-by-country/>
- Zhang, J., & Zhou, M. (2019). *Factors influencing consumer purchasing behavior of natural cosmetics: A qualitative study in Uppsala, Sweden*. Uppsala University.



## **Dhanush Priyan Mahesh. FACTORS AFFECTING CUSTOMER SATISFACTION IN THE LATVIAN HOTEL INDUSTRY**

*EKA University of Applied Sciences  
Master's Study Program "Business Administration"  
Scientific Advisor: Dr.oec., Professor Jeļena Titko*

### **Abstract**

**Research relevance:** Based on results on the research Ensuring customer experience and satisfaction is a necessity for any successful business, Measurement in customer satisfaction is important to analyse the business, Customer satisfaction is a crucial factor in determining the success and the long-term viability of an organization.

**Research goal:** To identify the factors affecting customer satisfaction in the Latvian hotel industry

**Research methods:** To achieve the research goals, survey among customer and employees of Latvian hotels were surveyed. Data processing is done by frequency analysis and correlation analysis.

**Main findings:** As the result of analysis the elements influencing customer satisfaction within the Latvian hospitality sector.

*Keywords: customer; satisfaction; service quality; amenities; location; cleanliness; factors affecting customer satisfaction.*

### **Introduction**

Customer plays the key role in any business; the success of the business cannot be imagined without the customer. It is important to work intimately with one's customer. Customer is an important part of the business and the market. To ensure organizations, need to deliver items and administration of generally excellent quality that yield exceptionally satisfied and loyal customer (Fecikova, 2004). For numerous years customer loyalty has been a significant objective of business organizations since it has been esteemed to influence customer maintenance and organizations' market share (Hansemark & Albinsson 2004). Yet, satisfaction is an individual perception of pleasure or the disappointment. If people's desire level meets their degree of satisfaction additionally expands but if in that point frustration comes.

Customer satisfaction is significant if people's desire level meets their degree of satisfaction additionally expands but if not in that point frustration comes. Customer satisfaction is significant for every organization, whether they are in service sector or in the private sector. It's not possible to satisfy each and every customer. If the customer likes the item, then they express satisfaction for the item after use (Yao et al, 2019). Customer satisfaction is called customer feedback as assessment after buying goods or services compared as their expectations. According to Razak et al. (2016), customer satisfaction is estimated by utilizing the customer expectations with the presentation of the goods or services that can address the needs and expectations of the customer. A satisfied customer indicated that there is a similarity between the performance of the product and service with the expectation of the customer, where it will attract them to repurchase the items. Simultaneously, a disappointed customer would persuade different customers to not re-buy and subsequently they will move to another service provider.

Initially, customer satisfaction is a significant segment of a business procedure, just as customer maintenance and item repurchase. Customer satisfaction is an indicator that predicts the future customers loyalty (Hill et al., 2007). Disappointed customer would persuade different customers to not re-buy and subsequently they will move to another service provider. Initially, customer satisfaction is a significant segment of a business procedure, just as customer maintenance and item repurchase. Customer satisfaction is an indicator that predicts the future customers loyalty (Hill et al., 2007).

Hospitality is a vast sector, and many people think of the kind of organizations which consider hospitality brands, and a much more modest number can explain what is and is the company fairly and correctly. This implies the essence and style of the changes in the organization as do the kinds of food and celebration and the levels of knowledge and expertise used at all levels of the company. The hospitality industry refers to a variety of organizations and administrations connected to recreation and customer satisfaction. The characteristics aspect of hospitality was also pointed out by Hallak et al. (2019), who focuses instead of providing food for necessities and fundamental values on the thinking of luxury, pleasure and experience.

## Literature Review

### Models of Service Quality

According to Gupta (2017), service quality is divided into two: first is tangible services (furniture, building, rooms, décor etc) and second is intangible service (personal touch, surprise, felling special) Gupta further argues that in today's world all hotels are almost same in their tangible factor. However, the thing which impress the consumers are the intangible services which attract them. Applying to the hospitality industry, there have been numerous studies that examine attributes that travellers may find important regarding customer satisfaction (Nomnga, 2015). Among all three most popular models to measure customer satisfaction and service quality in the hotel industry are SERVEQUAL, HOLSERVE. Lodging quality index (LQI) and DINESERVE. Each model has its strength and has been used flexibly in hotel industry to present literatures relevant to this research and to provide a theoretical framework.

### SERVQUAL Model

According to Abuukhalifeh (2012) SERVQUAL model allows customers to evaluate quality of a service based on five distinct dimensions namely tangibles, reliability, responsiveness, assurance and empathy on which service quality and customer satisfaction can be judged. The model was developed by Parasuraman, Zeithaml and Berry in 1988 as a tool of identifying service quality shortfall and is based on the premise that customers can evaluate a firm's service quality by comparing their perception of its service quality with their own expectations (Waitiki, 2014). Esshetie et al. (2016) argue that commitment towards quality improves the guest's level of satisfaction and increases profits as well as consequently the benefits gained by the guest and the employee. Further highlighted that on the opposite mistakes in service provision cost the hotel money and its reputation many suffer. This is the non-quality cost concept.

### Assurance

This refers to the knowledge and courtesy of employees and their ability to inspire, convey trust and confidence in hotel guests. The assurance dimension may be measured using elements of (Awara & Anyadighibe, 2014).

### Reliability

This consists of four items such as my reservation was handled efficiently. Reliability is defined as the dependability, consistency and accuracy with which the service is performed by the provider as well as hotel’s ability to perform services on time right at the first time. Dependability is defined as the service provider is able to provide what is needed and to be trusted while accurately is defined as service provider is able to achieve the outputs and that are correct. High service reliability refers to the error free performance provided by the service provider. Reliability of service included complaint handling, pricing and promises delivery. Besides, customers compare the expectation and the perception of the company’s delivery performance in order to evaluate their acceptability (Demoulin & Djelassi, 2013).

### Responsiveness

This refers to hotel’s willingness and flexibility to serve and help customer Minh et al. (2017) in a timely, efficient manner and includes items such as helpfulness, friendliness and warmth of the service staff

### Empathy

This is related to the caring personal attention extended to customer, as well as the level of understanding personnel demonstrate relative to customer needs and the consideration, individualized attention the hotel provides to its guests (Eshetie et al., 2016).

### Tangibles

This refers to the appearance of the hotel and staff, equipment personnel, physical facilities at hotel and rooms, communication materials and visual materials for customer (Minh et al., 2017). Elements within the tangibles dimension are cleanliness, space, atmosphere, appearance of server and location. SERQUAL model further, the model measures customer expectations and perceptions of service quality.

## Research Methodology

The impact of leadership on employee performance, the research methodology plays a fundamental role in providing a structured framework for data collection, analysis, and drawing meaningful conclusions. This section presents a detailed account of the research methodology employed in this study, elucidating the approach, data sources, data collection instruments, sampling techniques, and data analysis methods, all of which collectively contribute to the robustness of the research design. To identify the factors affecting customer satisfaction in the Latvian hotel industry, there was adopted a conceptual framework taken for the research study to understand CRM dimensions leading to hotel performance in terms of developing customer loyalty (see Fig.3).

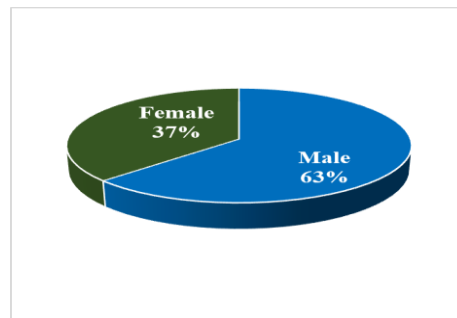

**Fig.3.** Adopted conceptual framework

## Results

This section provides information on the obtained results.

### Gender of Respondents



**Fig. 4.** Gender of respondents (Source: Created by the author)

In the sample of 230 respondents, 63% were male and 37% were female. This distribution indicates a higher representation of males compared to females in the study population.

### Age of Respondents

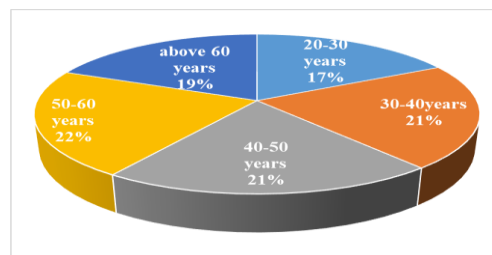

**Fig.5.** Age of respondents (Source: Created by the author)

The distribution of respondents by age shows that the majority are between 30 and 60 years old, with each age group comprising around 17-22% of the total sample. The 20-30 years age group is the smallest, while those above 60 years constitute 19% of the sample.

### Educational Qualification of Respondents

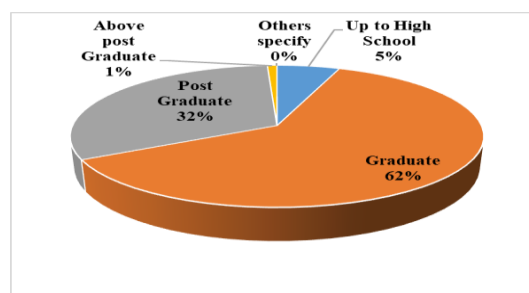

**Fig.6.** Educational qualification of respondents (Source: Created by the author)

The majority of respondents, 62%, hold a graduate degree, while 32% have completed post-graduate studies. Only 6% have an educational qualification up to high school, and a negligible percentage, 1%, have qualifications above post-graduate level.

### Purpose of Travel of Respondents

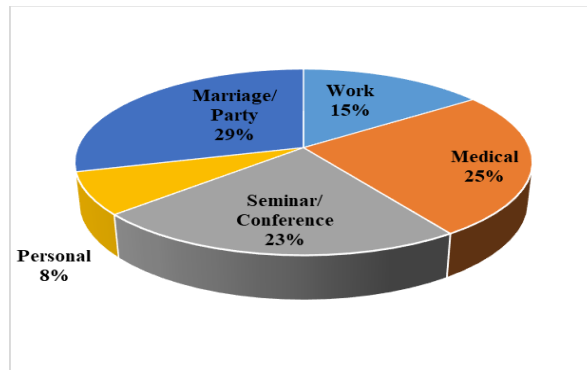

**Fig.7.** Purpose of Travel of of respondents (Source: Created by the author)

Respondents' purpose of travel varies, with the largest proportion, 29%, traveling for marriage or parties, followed by medical reasons at 25%. Additionally, 23% travel for seminars or conferences, while work-related travel and personal reasons represent 15% and 7% respectively.

### Occupation of Respondents

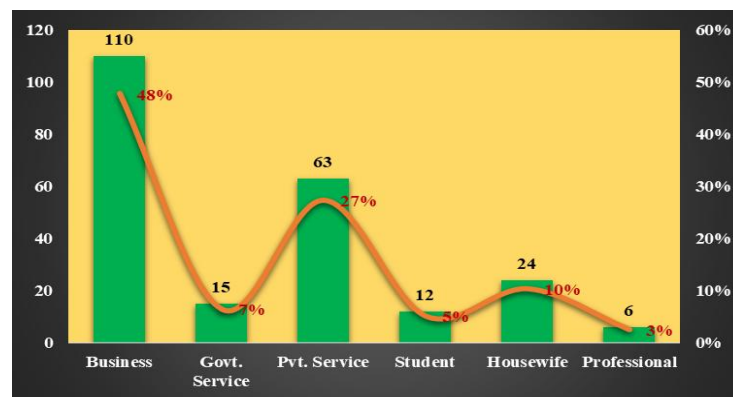

**Fig.8.** Occupation of respondents (Source: Created by the author)

The occupation breakdown indicates that 48% of respondents are engaged in business, while 27% work in private services and 10% are housewives. Government service and professional occupations represent smaller proportions, at 7% and 3% respectively, with students comprising 5% of the sample.

### Average Number of Days Spend in the Hotel by Respondents

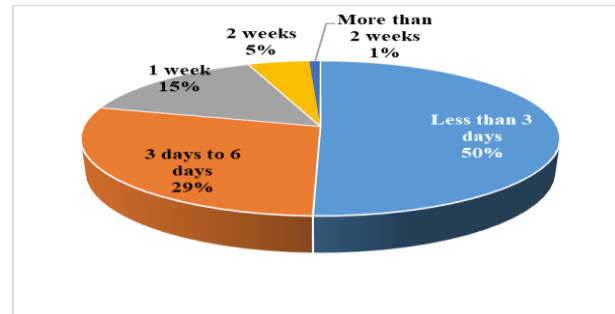

**Fig.9.** Average number of days you spend in the hotel of of respondents (Source: Created by the author)

The majority of respondents, 50%, spend less than 3 days in the hotel, while 29% stay for 3 to 6 days. Additionally, 15% stay for one week, while smaller proportions, 5% and 1%, stay for 2 weeks or more than 2 weeks, respectively.

The identified factors that were considered important by respondents in relation to providing customers satisfaction towards hotel services are available in Table 1.

**Table 1.** Important factors for customers satisfaction for hotel services (Source: Created by the author)

No.	Parameters/Factors	Strongly Agree	Agree	Neutral	Disagree	Strongly Disagree	Total
1	Location of Hotel	15%	67%	18%	0%	0%	100%
2	Parking facilities	48%	36%	11%	3%	2%	100%
3	Cleanliness in Hotel	78%	6%	10%	0%	6%	100%
4	Quality of food	44%	40%	8%	6%	1%	100%
5	Washroom Facilities	52%	41%	2%	3%	3%	100%
6	Timeliness of room service	52%	43%	0%	3%	2%	100%
7	Pricing of Food	50%	39%	9%	2%	0%	100%
8	Appearance of the staff 1	56%	30%	9%	3%	1%	100%
9	Behaviour of employees	57%	33%	8%	2%	0%	100%
10	Pick and Drop Facility	58%	33%	7%	1%	0%	100%
11	Understanding guest specific needs	57%	35%	3%	5%	0%	100%
12	Maintaining the confidentiality of customers data base	60%	37%	0%	2%	1%	100%
13	Trust on the employees of the hotel	56%	30%	9%	3%	1%	100%
14	Cleanliness of this hotel needs attention of the management	57%	33%	7%	2%	0%	100%

Notably, cleanliness in the hotel emerges as the most significant factor, with 78% of respondents strongly agreeing on its importance. This is closely followed by trust in hotel employees and maintaining confidentiality, both scoring high at 60%. Other factors such as the behavior of employees, understanding guest-specific needs, and appearance of the staff are also highly valued, with over 50% of respondents strongly agreeing on their importance. Parking facilities, washroom facilities, and timeliness of room service are also deemed important, although to a slightly lesser extent, with around 50% strongly agreeing on their significance. Pricing of food and pick and drop facility are also considered important by roughly half of the respondents. These findings highlight the critical role of cleanliness, staff behavior, and guest-centric services in ensuring customer satisfaction in hotel services.

The results on the levels of satisfaction in terms of services provided during stay at the hotel are summarized in Table 2.

**Table 2.** Satisfaction levels for the experiences hotel services (Source: Created by the author)

No.	Parameters	Strongly Agree	Agree	Neutral	Disagree	Strongly Disagree	Total
1	I am satisfied with the behavior of employees of this hotel.	60%	31%	8%	1%	0%	100%
2	I am satisfied with the physical facilities available in this hotel.	57%	31%	5%	0%	7%	100%
3	I am overall satisfied in dealing with this hotel 33 I would recommend this hotel to other people.	48%	38%	2%	3%	9%	100%
4	I would encourage friends & relatives to visit this hotel.	50%	38%	2%	4%	5%	100%
5	I would consider this hotel as my first choice when I need a hotel service.	49%	35%	9%	3%	4%	100%

The positive level of satisfaction with the services provided during the stay at the hotel. Sixty percent of respondents strongly agree that they are satisfied with the behavior of hotel employees, indicating a high level of approval in this aspect. Similarly, 57% express satisfaction with the physical facilities available at the hotel. In terms of overall satisfaction, 48% strongly agree and 38% agree, while only a small percentage express disagreement or strong disagreement. Additionally, half of the respondents indicate that they would encourage friends and relatives to visit the hotel, and nearly half consider it as their first choice for hotel services. These findings suggest that the majority of guests are content with the services offered and are likely to recommend the hotel to others, reflecting positively on its reputation and potential for repeat business

The results on the overall services experienced during the last hotel stay are available in Table 3.



**Table 3.** Overall services during the last hotel stay (Source: Created by the author)

No.	Parameters	Strongly Agree	Agree	Neutral	Disagree	Strongly Disagree	Total
1	The hotel provided a safe environment	41%	36%	10%	5%	8%	100%
2	Charges on my account were clearly explained	41%	33%	12%	5%	10%	100%
3	The hotel meals were of high quality	45%	47%	8%	0%	0%	100%
4	Actual services of the hotel match with promised services	44%	36%	7%	7%	7%	100%
5	Rating of hotel on booking sites is authentic	50%	35%	7%	3%	5%	100%
6	Overall Satisfaction towards the hotel	48%	36%	9%	3%	5%	100%

The positive perceptions of the overall services offered by the last visited hotel. Forty-eight percent of respondents strongly agree with their overall satisfaction towards the hotel, while an additional 36% agree, reflecting a majority of guests expressing contentment. Furthermore, a significant proportion of respondents strongly agree (41%) or agree (36%) that the hotel provided a safe environment, indicating a high level of satisfaction with safety measures. Similarly, respondents express satisfaction with the quality of meals, with 45% strongly agreeing and 47% agreeing that the hotel meals were of high quality. Additionally, the majority of respondents (44% strongly agree, 36% agree) perceive that the actual services of the hotel match with the promised services, suggesting consistency in service delivery. However, there are areas for improvement, as indicated by some respondents expressing neutrality or disagreement regarding the clarity of charges on their account (12% neutral, 5% disagree) and the authenticity of the hotel's rating on booking sites (10% neutral, 8% disagree). Overall, while the hotel garners positive feedback in several aspects, attention to transparent communication about charges and ensuring authentic ratings on booking sites could enhance guest satisfaction further.

The results on the impact of implementing customer relationship management on customer satisfaction are provided in Table 4.

**Table 4.** Impact of implementing customer relationship management on customer satisfaction (Source: Created by the author)

Nos	Parameters/Factors	Strongly Agree	Agree	Neutral	Disagree	Strongly Disagree	Total
1	The hotels management gives importance to our feedback.	42%	35%	11%	4%	8%	100%
2	Any problem when informed to the manager was given proper attention by the staff & manager	57%	23%	11%	3%	4%	100%

3	Accepting cancellation through online is one of the important considerations for me	48%	35%	10%	1%	6%	100%
4	Availability of loyalty cards to potential customers is one important factor for hotel selection	50%	32%	6%	7%	6%	100%
5	This hotel always tries to build up very close relationship	52%	37%	0%	3%	8%	100%
6	This hotel provides needed information in the specified time	42%	36%	10%	4%	8%	100%

A positive impact of implementing customer relationship management (CRM) on customer satisfaction in various aspects. Firstly, 42% of respondents strongly agree and 35% agree that hotel management gives importance to their feedback, indicating responsiveness to guest input. Additionally, a majority of respondents (57%) strongly agree that any problem reported to the manager receives proper attention from staff and management, highlighting effective issue resolution. Moreover, factors such as accepting cancellations online (48% strongly agree, 35% agree) and availability of loyalty cards (50% strongly agree, 32% agree) are deemed important considerations for hotel selection, suggesting that CRM practices contribute to customer satisfaction and loyalty. Furthermore, a significant proportion of respondents (52% strongly agree, 37% agree) perceive that the hotel always tries to build a close relationship with guests, emphasizing the importance of relationship-building efforts in enhancing satisfaction. Lastly, providing needed information in a timely manner is valued by respondents, with 42% strongly agreeing and 36% agreeing, indicating the effectiveness of communication strategies in CRM implementation. Overall, the findings underscore the positive impact of CRM initiatives on enhancing customer satisfaction by fostering responsiveness, loyalty programs, relationship-building efforts, and effective communication practices.

### Conclusions

The analysis of development trends in the Latvian hotel industry reveals shifts in customer preferences, technology integration, and sustainability initiatives. The significance of customer relationship management (CRM) practices in enhancing customer satisfaction within the hotel industry. Results indicate that CRM initiatives such as feedback responsiveness, issue resolution, loyalty programs, and effective communication contribute positively to guest satisfaction, emphasizing the importance of CRM strategies in fostering guest loyalty and satisfaction. Customer relationship management (CRM) practices significantly influence customer satisfaction in the hotel industry. Key findings reveal that hotels prioritizing guest feedback, promptly addressing issues, offering loyalty programs, and fostering close relationships with guests yield higher satisfaction levels. Notably, aspects such as problem resolution, online cancellations, availability of loyalty cards, and timely information provision significantly impact customer perceptions. These results underscore the importance of CRM in enhancing guest experiences and loyalty. Hotel management can leverage these findings to implement effective CRM strategies, thereby fostering stronger relationships with guests and ultimately improving overall satisfaction and loyalty in the hospitality sector. In conclusion, these comprehensive approaches shed light on current industry dynamics and provide actionable insights to enhance customer satisfaction and drive sustainable growth in the Latvian hotel sector.



## References

- Awara, N. F., & Anyaadighibe, J. A. (2014). The relationship between customer satisfaction and loyalty: A study of selected eateries in Calabar, Cross River State. *Interdisciplinary Journal of Contemporary Research in Business*, 5(9), 110-125.
- Chinomona R, Masinge G., & Sandada, M. (2014). The influence of e-service quality on customer perceived value, customer satisfaction and loyalty in South Africa. *Mediterranean Journal of Social Sciences*, 5 (9), 331-341.
- Cooper, C. R., & Schinder, P. S. (2008). *Business research methods Boston*. McGraw Hill.
- Deemirgunes, B. K. (2015). Relative importance of perceived value, satisfaction and perceived risk on willingness to pay more. *International Review of Management and Marketing*, 5(4), 211-220.
- Eshetie, S. K., Sevoum, W., & Ali, S. H. (2016). Service quality and customer satisfaction in hospitality industry: The case of selected hotels in Jimma Town, Ethiopia. *Global Journal of Management and Business Research: E. Marketing*, 16(5), 73-86.
- Forozia, A., Zadeh, M. S., & Galani, M. H. N. (2013). Customer satisfaction in hospitality industry: Middle East tourists at 3-star hotels in Malaysia. *Research Journal of Applied Sciences, Engineering and Technology*, 5(17), 4329-4335. <http://dx.doi.org/10.19026/rjaset.5.4425>
- Gupta, A. (2017). Customer Satisfaction in Relation to Service Quality. A conceptual study on Indian hotels. *International Journal of Applied Research*, 3(1), 302-305.
- Rizwan, A., Leifu, G., Yasirrafia, M., & Hassan, M. (2015). Role of perceived value customer expectation, corporate image and perceived service quality on the customer satisfaction. *The Journal of Applied Business Research*, 31(4), 1425-1437. <http://dx.doi.org/10.19030/jabr.v31i4.9328>
- Tussvadiyah, I. P. (2014). Toward a theoretical foundation for experience design in tourism. *Journal of Travel Research*, 53(5), 543-564. <http://dx.doi.org/10.1177/0047287513513172>



## **Ushan Eranga Dissanayake. IMPACT OF ADVERTISING APPEALS ON IMPULSIVE PURCHASING FOR CONSUMER DURABLES IN WESTERN PROVINCE IN SRI LANKA.**

*EKA University of Applied Sciences*

*Master's Study Program "Business Administration"*

*E-mail: ushandissanayake19@gmail.com*

*Scientific Advisor: Dr.oec., Assistant Professor Jevgenija Dehtjare*

### **Abstract**

**Research relevance:** Research relevance is established due to the fact that effective advertising influences attitudes toward brands and ultimately leads to purchase intentions. Additionally, TV advertising not only changes emotions but also delivers significant messages exerting a far-reaching influence on people's daily lives. Furthermore, consumers may experience an urge to buy impulsively when visually encountering cues such as promotional incentives. Store environments influence consumers' emotional states; which may further lead to impulse buying inside the store.

**Research goal:** To examine the impact of advertising appeals on consumer impulsive buying behaviour towards consumer durable products in the Western Province of Sri Lanka in order to provide recommendations on the application of advertising appeals.

**Research methods:** A quantitative study was conducted under this research using a survey method; and convenient sampling methods was employed. To test the hypothesis; the researcher used regression analysis techniques; identifying the impact of advertising appeals on impulsive purchasing for consumer durables in the Western Province of Sri Lanka; addressing the significance of each independent variable.

**Main findings:** Advertising appeals exert a significantly positive influence on impulsive buying behaviour for consumer durables. Moral appeal demonstrates greater significance compared to rational and emotional appeals.

*Keywords: advertising appeals; impulsive buying; consumer durables; buying behaviour.*

### **Introduction**

Consumer buying patterns have evolved significantly in recent decades, notably with the surge of online shopping following the industrial revolution and the COVID-19 pandemic. This shift is particularly pronounced in the consumer durables sector, encompassing items such as refrigerators, TVs, and mobile phones, reflecting substantial changes in spending behaviour and disposable income utilization.

The topicality of research is justified by the situation in Western Province in Sri Lanka, where the consumer durables market is expanding rapidly due to heightened demand and a burgeoning population. With both local and multinational competitors vying for market share, consumers face a plethora of choices. Statista Market Insights reports that consumer spending on durables in Sri Lanka has been on the rise, increasing from USD 1,044 million in 2018 to USD 1,306 million in 2023. Similarly, advertising expenditures surged from EUR 94 million in 2018 to EUR 196 million in 2023. The data from the Central Bank of Sri Lanka reveals a significant increase in expenditures on furnishings and household maintenance, climbing from LKR 154,932 million in 2018 to LKR 228,692 million in 2022.

This study aims to address the research gap by investigating how advertising appeals influence impulsive buying behaviour among consumers in the Western Province in Sri Lanka. The objective is to provide marketers and policymakers with insights to develop effective and culturally appropriate advertising strategies. Understanding the role of advertising in impulsive buying can ensure ethical consumer persuasion and targeted marketing approaches, as emphasized by previous research.

The aim of this study is to critically analyse the impact of different advertising appeals on impulsive buying behaviour toward consumer durables in Western Province in Sri Lanka. This objective arises from the need to fill a significant research gap identified through literature review and consideration of the unique socio-economic context.

Historical and contemporary marketing theories, such as the AIDA and DAGMAR models, suggest that advertising exerts significant persuasive power over consumer behaviour. However, these models lack specificity regarding impulsive buying triggers, particularly in emerging economies like Sri Lanka. Dholakia (2000) highlights the influence of immediate environmental and emotional appeals on impulsive buying decisions, indicating that specific advertising appeals may evoke varying levels of impulsivity.

Despite numerous studies on the consumer durables industry, there is a notable absence of research specific to the Sri Lankan consumer durable market. Therefore, there is a significant opportunity to identify gaps in this area and address the rising demand for consumer durables. Furthermore it is important to explore how different types of advertising appeals impact impulsive buying behaviour in specific contexts.

Despite the acknowledged influence of advertising on buying behaviour globally, there remains a considerable gap in empirical research focused on the specific impacts of advertising appeals on consumer durables in Sri Lanka.

The study tests the following hypotheses:

- H1: There is a positive significant relationship between rational advertising appeal and the impulsive buying behavior.
- H2: There is a positive significant relationship between emotional advertising appeal and the impulsive buying behavior.
- H3: There is a positive significant relationship between moral advertising appeal and the impulsive buying behavior.

The study employs a combination of primary and secondary data collection methods. Primary data was gathered through surveys involving 146 respondents from the Western Province in Sri Lanka, focusing on their reactions to different advertising appeals in consumer durables commercials. Secondary data analysis involved reviewing existing literature and market studies to contextualize consumer behavior within the region. The data collected were processed using statistical tools such as SPSS and Microsoft Excel, employing techniques like frequency analysis, mean rating, and weighted mean rating to derive conclusive insights.

Different advertising appeals have varying levels of impact on impulsive buying behavior among consumers in Western Province, Sri Lanka. Initial findings suggest that moral appeals tend to have a stronger influence on impulsive purchases compared to emotional and rational appeals. These insights are critical for companies operating in the competitive market of consumer durables, as understanding these dynamics can significantly enhance the effectiveness of their advertising campaigns.



## Literature Review

Advertising plays a pivotal role in modern marketing strategies, aiming to communicate with consumers and influence their purchasing decisions. To understand the dynamics of advertising effectiveness and consumer behavior, various models and appeals have been explored in academic literature. Advertising is broadly defined as a means of communication, paid for by identified sponsors, to inform or influence people about products or services (Advertising Association of UK, 2011). It involves presenting a controllable message through paid media, aiming to inform, persuade, and remind consumers of a brand's value proposition (Kotler, 1991).

The AIDA model, developed by Strong in 1925, outlines a behavioral sequence in advertising, aiming to raise awareness, stimulate interest, create desire, and prompt action (Hackley, 2005). This model emphasizes the importance of guiding consumers through a structured process to achieve advertising objectives effectively.

The DAGMAR model, introduced by Russell Colley, focuses on setting measurable objectives for each stage of communication in advertising campaigns (Smith & Taylor, 2002). It emphasizes understanding customer comprehension levels and measuring advertising results to ensure effectiveness.

Lavidge & Steiner's Hierarchy-of-Effects Model, illustrates the stages consumers go through during the buying process, emphasizing the sequential nature of consumer decision-making (Miller & Jones, 2015). While designed to be followed linearly, consumers may sometimes skip ahead in the process, making it crucial for advertisers to adapt strategies accordingly.

Advertising appeals serve as creative tools to capture audience attention and influence their buying behavior. Emotional appeals target consumers' feelings and perceptions, while rational appeals focus on practicality and functionality (Kotler, 1991). Moral appeals, on the other hand, aim to evoke consumers' senses of right and wrong, often associated with social or ethical causes (Foley & Pastore, 2020).

Understanding consumer behavior is essential for developing effective marketing strategies. It involves studying the processes consumers use to make purchase decisions, as well as factors influencing their choices. Impulse buying behavior, characterized by sudden, unplanned purchases driven by strong emotional or hedonic motives, has garnered significant attention in consumer behavior research.

Advertising appeals and consumer behavior are intricately linked, shaping the effectiveness of marketing efforts. By employing various appeals and understanding consumer decision-making processes, marketers can create impactful advertising campaigns that resonate with target audiences and drive desired actions. The link between advertising appeals and impulsive buying behavior is profound. Emotional appeals, such as those evoking joy or excitement, often play a significant role in triggering impulsive purchases (Middleton, 2017). Similarly, moral appeals that resonate with consumers' sense of social responsibility can spur impulsive buying, particularly for products associated with ethical causes (Patidar, 2019). On the other hand, rational appeals, focusing on practical benefits and features, may mitigate impulsive buying tendencies by encouraging consumers to make informed decisions based on product utility. However, studies suggest that emotional appeals tend to have a stronger impact on impulsive buying behavior compared to rational appeals (Smith & Johnson, 2020).

In essence, advertising appeals wield considerable influence over consumer behavior, including impulsive buying tendencies. By understanding the interplay between different appeals and consumer psychology, marketers can craft more effective advertising strategies that resonate with target audiences and drive desired actions, whether it be planned or impulsive purchases.

## Research Methodology

In this research, author aim to establish relationship between advertising appeals and impulsive buying behavior. This involves breaking down the concepts into measurable variables and forming hypotheses based on existing literature.

H1: There is a positive significant relationship between rational advertising appeal and the impulsive buying behavior.

Rational appeals in advertising focus on logical details and practical benefits of products. Research suggests that such appeals provide comprehensive product information, potentially enhancing consumer interest and purchase intentions (Smith & Lee, 2015). Therefore, author hypothesize There is a positive significant relationship between rational advertising appeal and the impulsive buying behavior.

H2: There is a positive significant relationship between emotional advertising appeal and the impulsive buying behavior.

Emotional appeals in advertising evoke feelings such as warmth, affection, and excitement. Studies have shown that positive emotional responses to advertisements can influence brand attitudes and purchase intentions (Aaker & Norris, 2013). Therefore, author hypothesize There is a positive significant relationship between emotional advertising appeal and the impulsive buying behavior.

H3: There is a positive significant relationship between moral advertising appeal and the impulsive buying behavior.

Moral appeals in advertising often emphasize social responsibility and ethical values associated with products or services. While research in this area is limited, it is argued that emphasizing ethical aspects can enhance persuasiveness and influence purchase decisions (Darley & Smith, 2013). Thus, author hypothesize There is a positive significant relationship between moral advertising appeal and the impulsive buying behavior.

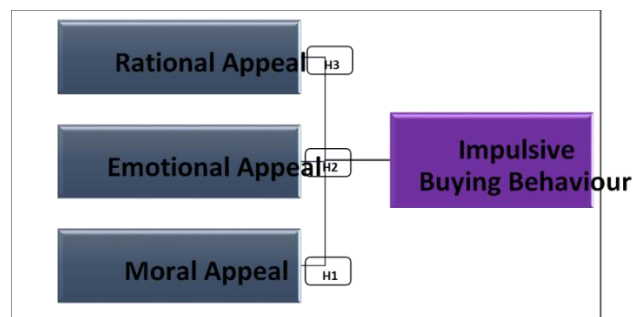

**Fig.1.** Conceptualization framework (Source: Created by the author)

To operationalize the concepts, author identify specific variables and indicators for each advertising appeal and impulsive buying behavior. For example, rational appeal variables include product features and cost-benefit arguments. Emotional appeal variables include music, love, and humor in advertisements. Moral appeal variables include social responsibility and citizenship. Impulsive buying behavior is assessed through indicators such as spontaneity and immediacy.

This study adopts a positivist quantitative approach, utilizing both primary and secondary data. Secondary data is gathered from various sources including online journals, textbooks, and previous



research. Primary data is collected through surveys distributed via online platforms such as Google Forms. The research design is cross-sectional, focusing on individual responses from the Western Province in Sri Lanka. The questionnaire consists of three sections: general questions, advertising appeal assessment, and impulsive buying behavior evaluation. Respondents use Likert scales to indicate their agreement with statements. The questionnaire underwent testing to ensure clarity and comprehension among participants. A sample of respondents from the Western Province in Sri Lanka was selected via online platforms. Out of over 200 distributed questionnaires, 146 responses were received, forming the basis for analysis.

Descriptive statistics, including frequencies, percentages, and Pearson's correlation analysis, are employed for data analysis. Central tendency and measures of dispersion are calculated using software such as SPSS and Excel. Inferential statistical tools, such as Pearson Correlation Technique, are utilized to test hypotheses and evaluate relationships between advertising appeals and impulsive buying behavior. Demographic data is presented descriptively to provide context for the study.

## Results

Firstly, considering the demographic analysis, the sample composition analysis reveals a slight female dominance, with 51% females and 49% males, indicating near gender balance. Among 146 respondents, 51% are aged 31 to 40, and 30% are aged 21 to 30, demonstrating a higher propensity for consumer durable purchases within these age brackets. Those above 40 represent 14% of shoppers, while those below 20 are negligible due to lower purchasing power. Education-wise, 33% are Bachelor level, 32% have passed GCE A/L, and 16% are professionally qualified, suggesting a preference for shopping at consumer durable retail outlets across education levels. Income distribution shows 36% earning between Rs.50,001 and 100,000, with 27% in the Rs.100,001 to 200,000 bracket, and 16% earning less than Rs.50,000. Only 5% earn above Rs.300,000, and 5% preferred not to disclose. Regarding employment, 64% are in the private sector, while government occupations account for 19%. Students comprise 8%, self-employed individuals 6%, unemployed 2%, and retirees 1%. This data provides insights for consumer durable retail outlets, especially given the dominance of middle-income private sector employees among respondents.

The analysis indicates high internal consistency of the questionnaire with Cronbach's alpha values of 0.768 for rational appeal, 0.853 for emotional appeal, 0.765 for moral appeal, and 0.717 for impulsive buying. Despite this, only 38% of the 146 respondents shop once a year, suggesting infrequent visits to consumer durable showrooms. Singer emerges as the most preferred retail channel with 43% of the votes, likely due to its widespread showroom network across Sri Lanka. Damro follows with 31% of the votes, while Sinthagiri is the least preferred. Among Singer customers, 28% prioritize product quality, while 38% of Damro customers value product quality, and 35% prioritize after-sales service. Interestingly, 57% of instant buyers of consumer durables are women, indicating a tendency for spontaneous purchases, while 50% of respondents aged 31-40 constitute the majority of instant buyers, likely due to higher disposable income. These findings offer valuable insights for marketers into consumer showroom visit frequency, brand preferences, and purchasing behaviour across different demographics.

The Descriptive Statistics reveal a mean value of 4.44 for Rational Appeal, indicating high agreement among respondents. Emotional Appeal scores a mean of 3.21, suggesting respondents were mostly neutral. Moral Appeal records a mean of 3.97, indicating agreement among respondents. Impulsive



Buying averages 2.899, suggesting respondents were mostly neutral. These findings provide insights into the levels of agreement among respondents regarding different independent variables.

The correlation analysis reveals a significant relationship between Rational Appeal and Impulsive Buying, with a coefficient of 0.200, indicating a weak positive linear relationship. Emotional Appeal also shows a significant relationship with Impulsive Buying, with a coefficient of 0.322, indicating a moderate positive linear relationship. Similarly, Moral Appeal demonstrates a significant relationship with Impulsive Buying, with a coefficient of 0.379, representing a moderate positive correlation. These findings provide insights into the relationships between different advertising appeals and impulsive buying behaviour in consumer durables.

The regression analysis indicates that Rational Advertising Appeal explains 4% (R square = 0.040) of the variation in impulsive buying behaviour, while Emotional Advertising Appeal explains 10% (R square = 0.109), and Moral Advertising Appeal explains 14% (R square = 0.140). The higher R square value for Moral Appeal suggests it has a stronger influence on impulsive buying behaviour compared to Rational and Emotional Appeals. However, the majority of the variation in impulsive buying behaviour is attributed to other factors not accounted for in the analysis.

**Table 1.** Regression of independent and dependent variable (Source: Created by the author)

Variable	R	R Square	Adjusted R Square	Std. Error of the Estimate
Rational Appeal	.200 <sup>a</sup>	.040	.035	.713
Emotional Appeal	.322 <sup>a</sup>	.109	.105	.687
Moral Appeal	.379 <sup>a</sup>	.144	.139	.673

The summary of hypothesis testing indicates acceptance of all three hypotheses. H1 confirms a weak positive relationship (R = 0.2) between Rational Appeal and Impulsive Buying. H2 supports a moderate positive relationship (R = 0.32) between Emotional Advertising Appeal and Impulsive Buying. H3 confirms a moderate positive relationship (R = 0.2) between Moral Appeal and Impulsive Buying. The significance level (P < 0.005) validates these relationships, providing insights into the impact of different advertising appeals on impulsive buying behavior.

## Conclusions

This research explores the impact of advertising appeals on impulsive buying behaviour for consumer durables in the Western Province of Sri Lanka. The consumer durable industry is expanding rapidly, both in local and international markets. Major companies in this sector invest heavily in advertising through TV, radio, and newspapers to attract new customers and retain existing ones.

In Sri Lanka, consumer spending on durables has been increasing yearly, from USD 1,044 million in 2018 to USD 1,306 million in 2023 according to Statista Market Insights. Advertising expenditures have also grown, from EUR 94 million in 2018 to EUR 196 million in 2023. Furthermore, expenditure on furnishings and household maintenance reported by the Central Bank of Sri Lanka saw a significant increase from LKR 154,932 million in 2018 to LKR 228,692 million in 2022.



The competition in Sri Lanka's consumer durables market is intense. Companies must achieve top-of-mind awareness to survive. This necessitates an evaluation of the returns on advertising spending to ensure that the advertisements not only remind and persuade but also effectively drive sales.

This study aims to determine if advertising appeals (rational, emotional, moral) can trigger impulsive purchases among consumers in this region. The author used both primary and secondary data sources. Secondary data came from previous research, while primary data was collected through a survey with 146 respondents from the Western Province in Sri Lanka.

The relationship between advertising appeals and impulsive buying behaviour was analysed using a conceptual framework presented in figure 01. Data was analysed with descriptive statistics and summary of the findings have been mentioned in the above result section.

Overall, the study examines how different types of advertising appeals influence consumer behaviour in the context of Western Province in Sri Lanka, providing insights that are crucial for companies to refine their marketing strategies effectively.

## References

Aaker, D. A., & Norris, D. (2003). Characteristics of TV commercials perceived as informative. *Journal of Advertising Research*, 22(2), 61-71.

Advertising Association of UK. (2011). *The economic times*. <http://economictimes.indiatimes.com/definition/advertising>

Darley, W., & Smith, R. (2013). Advertising claim objectivity. *Journal of Marketing*, 57, 100-114.

Ghirvu, A. I. (2013). The AIDA model for advergaming. *The USV Annals of Economics and Public Administration*, 13(1), 90-98.

Kotler, P. (1991). *Marketing management: Analysis, planning, implementation and control*. Prentice-Hall.

Middleton, A. (2017). Types of advertising appeals most commonly used by brands. *Visme.com*. <https://visme.co/blog/types-of-advertising-appeals/>

Novia, J. (2020). The effect of visual merchandising on impulsive buying with impulsive buying tendency as moderating variable. *The Winners*, 16(1). <http://dx.doi.org/10.21512/tw.v16i1.1537>

Patidar, M. (2019). MBA Notes - Advertising Appeals. Available at: <https://www.enotesmba.com/2012/07/mba-notes-advertising-appeals.html>

Weber, I. (2018). 11 Emotional Advertising Examples Most Used by Brands. Available at: <https://www.creatopy.com/blog/emotional-advertisingexamples/>



## **Nimesha Harshani Gunawardhana Asuramana Pedige. CONSUMERS' ATTITUDE TOWARDS GREEN PACKAGING: EVIDENCE FROM FOOD AND BEVERAGE INDUSTRY IN SRI LANKA**

*EKA University of Applied Sciences*

*Master's Study Program "Business Administration"*

*E-mail: Gunawardhanime1114@gmail.com*

*Scientific Advisor: Dr.oec., Assistant Professor Jevgenija Dehtjare*

### **Abstract**

**Research relevance:** In recent years; people have been paying more attention to taking care of the environment. Companies are trying new ways to reduce their impact on the environment; and one popular idea is using green packaging. Green packaging means using materials and designs that don't harm the environment much; from when the product is made until it's thrown away. It's supposed to save resources; produce less waste; and create fewer greenhouse gases. But whether it works depends a lot on what people think about it. If consumers like the idea of green packaging; it can help businesses make products that people want; while also being better for the environment. So; it's important for companies to know what consumers think about green packaging.

**Research goal:** To evaluate factors that affect consumers' attitude towards green packaging in the food and beverage industry in Sri Lanka in an order to achieve sustainable packaging solutions.

**Research methods:** The data collection method encompassed a survey for primary data collection, and literature review for secondary data. The data processing and interpretation methods included regression analysis, correlation analysis, thematic analysis, and descriptive analysis.

**Main findings:** The findings of this study have been shown that environmental protection; types of packaging; behaving economically and knowledge have significant and positive relationship and impact with consumers' attitude towards green packaging.

*Keywords: green packaging; consumers' attitude; environmental protection; packaging machinery market.*

### **Introduction**

In recent years, the global focus on environmental sustainability has intensified, prompting industries to seek innovative solutions to reduce their ecological footprint. One such solution is the adoption of green packaging, aimed at minimizing environmental degradation throughout the product lifecycle. While the adoption of green packaging presents numerous benefits, its success hinges largely on consumer behavior and acceptance. Green packaging, also known as sustainable packaging or eco-friendly packaging, refers to the use of materials and design strategies that minimize environmental impact throughout the product lifecycle. It aims to reduce resource consumption, waste generation, and greenhouse gas emissions associated with packaging production, distribution, use, and disposal. Green packaging represents a holistic approach to packaging design and management, balancing environmental considerations with functional requirements and economic viability. By embracing green packaging principles, businesses can contribute to a more sustainable future while meeting consumer expectations for eco-friendly products and packaging solutions.

However, as a company, it matters how the consumer will behave towards the green packaging concepts of the company. It is important to understand that packaging often represents the only product exposure



consumers experience before purchase (Jestratišević et al., 2022). Therefore, green packaging should be appealing to consumers. The problem at hand is the lack of comprehensive understanding regarding the influence of customer behavior on the widespread adoption of green packaging practices by businesses. Despite growing awareness of environmental issues, consumers' attitudes, preferences, and purchasing decisions regarding green packaging remain complex and multifaceted. The researcher has selected three major production companies which are involved in production of food and beverages identified that, the major concerns of the particular companies were understanding how consumers perceive green packaging in terms of its environmental benefits, product attractiveness, and perceived value compared to traditional packaging alternatives, the level of awareness among consumers regarding the environmental impact of packaging materials, as well as their knowledge of sustainable packaging options available in the market, the factors that influence consumer behavior towards green packaging, including individual values, socio-cultural norms, pricing sensitivity, and convenience considerations, the barriers hindering the widespread adoption of green packaging by consumers, such as misconceptions, lack of trust in eco-labeling, perceived inconvenience, and resistance to change, effective communication strategies to educate and motivate consumers to embrace green packaging, including the role of advertising, labeling, and social influence were the major concerns of the companies and this is the reason to conduct the particular study.

Addressing these challenges requires interdisciplinary research efforts that integrate insights from consumer psychology, marketing, environmental science, and sustainability studies. By gaining a deeper understanding of consumer behavior towards green packaging, businesses can tailor their strategies to effectively promote sustainable practices while meeting consumer preferences and market demands. This study aims to fill the existing gap in literature by examining the intricate relationship between customer behavior and the adoption of green packaging, providing valuable insights for businesses, policymakers, and environmental advocates alike. Through empirical research and data-driven analysis, the researcher seeks to unravel the complexities surrounding consumer attitudes and behaviors towards sustainable packaging, ultimately contributing to the advancement of eco-friendly practices and the preservation of our planet's ecosystems.

The research object related to the food and beverages industry in Sri Lanka and subject related to consumer behavior towards green packaging. The aim of the research is to evaluate factors that affect consumers' attitude towards green packaging in the food and beverage industry in Sri Lanka and the research question have developed accordingly. Major identified data collection methods are surveys and secondary data analysis and data processing methods identified were descriptive, correlation and regression analysis and graphical interpretations. Novelty of the research was about Sri Lankan green packaging though the green packaging is popular in other countries. This research could use by the academics as literature and companies to improve their performances through improved green packaging systems and finally limitations have been discussed and major barrier identified for the limitation is given timeframe for the research.

## Literature Review

Packaging plays a crucial role in consumer goods by preserving quality, preventing loss, aiding transport, and enhancing market appeal, yet it often outlasts its contents and becomes waste post-use (Steenis et al., 2017). The findings suggest that companies should design packaging that decomposes easily to reduce its environmental impact (Igbomor, 2024). There are also major barriers to adopting these practices, including limited availability and high costs of sustainable materials, low demand, regulatory challenges, and quality control issues in production (Lekesiztürk & Oflaç, 2022). The food



and beverage industry in Sri Lanka is a significant contributor to the country's economy, with a growing focus on the importance of efficient and sustainable food packaging systems. This literature review aims to explore existing research and developments consumer attitudes towards green packaging within the Sri Lankan food and beverages context. Consumer attitudes toward green packaging have become increasingly important in recent years due to growing environmental awareness and concerns about the ecological impact of packaging materials.

### **Understanding Green Packaging**

Green packaging, also known as sustainable packaging, has gained significant attention in recent years due to growing environmental concerns and increased consumer awareness. Green packaging encompasses packaging materials and practices designed to minimize environmental impact throughout the product lifecycle. It includes attributes such as recyclability, biodegradability, use of renewable resources, and reduced carbon footprint. The scope of green packaging extends beyond material choices to encompass design, production, transportation, and end-of-life disposal.

Green packaging represents a critical aspect of sustainable development, offering environmental benefits, addressing consumer preferences, and driving innovation in the packaging industry. However, challenges such as cost constraints, regulatory hurdles, and infrastructure limitations need to be addressed to realize the full potential of green packaging. Businesses, policymakers, and consumers must collaborate to promote the adoption of sustainable packaging practices and accelerate the transition towards a circular economy.

Consumer perception plays a crucial role in driving the adoption of green packaging. Studies have shown that consumers are increasingly concerned about the environmental impact of packaging materials and prefer products with eco-friendly packaging. Green packaging can influence consumer purchasing decisions, brand loyalty, and willingness to pay a premium for sustainable products.

Despite its potential benefits, green packaging faces several challenges and limitations. These include higher production costs, limited availability of sustainable materials, regulatory barriers, and conflicting priorities between environmental goals and business objectives. Additionally, challenges related to recycling infrastructure and consumer education remain significant barriers to widespread adoption.

Businesses are increasingly adopting green packaging strategies to address consumer demand for sustainable products and reduce their environmental footprint. These strategies include eco-design, lightweighting, material substitution, and collaboration across the supply chain. Innovations such as bio-based plastics, compostable packaging, and reusable containers are driving advancements in sustainable packaging solutions.

### **Consumer Attitudes towards Green Packaging**

Understanding the factors that influence consumers' attitudes toward green packaging is crucial for businesses aiming to meet sustainability goals and cater to environmentally conscious consumers. One of the primary factors influencing consumers' attitudes toward green packaging is their level of environmental awareness and concerns. Research suggests that consumers who are more environmentally conscious are likely to have more positive attitudes toward green packaging. Environmental education and campaigns highlighting the environmental impact of traditional packaging materials can increase consumers' awareness and drive positive attitudes toward sustainable alternatives.

Consumers' perceptions of the environmental benefits associated with green packaging play a significant role in shaping their attitudes. Green packaging materials such as recyclable or biodegradable materials are often perceived as less harmful to the environment compared to traditional plastics. Communicating



the environmental benefits of green packaging through labeling and marketing strategies can enhance consumers' positive perceptions and attitudes toward sustainable packaging options.

Consumer perceptions of product quality and performance are critical factors influencing their attitudes toward green packaging. Research suggests that consumers may perceive products packaged in eco-friendly materials as being of lower quality or less durable compared to conventional packaging (Wandosell et al., 2021). Therefore, ensuring that green packaging maintains product integrity and meets consumers' performance expectations is essential for fostering positive attitudes toward sustainable packaging options. Price sensitivity and the perceived value of products packaged in green materials also influence consumers' attitudes toward green packaging. Studies have shown that consumers may be willing to pay a premium for products packaged in environmentally friendly materials if they perceive them as offering additional value or aligning with their sustainability values. However, the perceived affordability of green packaging options relative to traditional alternatives can impact consumers' willingness to choose sustainable packaging options.

The convenience and practicality of green packaging solutions also affect consumers' attitudes toward sustainability. Consumers may be reluctant to adopt green packaging options if they perceive them as less convenient or practical compared to traditional packaging formats (Sinha et al., 2020). Therefore, the development of innovative green packaging solutions that offer both environmental benefits and convenience is essential for enhancing consumer acceptance and attitudes toward sustainable packaging options (Wandosell et al., 2021).

Consumers' attitudes toward green packaging are influenced by various factors, including their level of environmental awareness, perceptions of environmental benefits, product quality and performance, price sensitivity, and convenience. Businesses can leverage these insights to develop effective marketing strategies, enhance product offerings, and address consumer concerns to promote the adoption of sustainable packaging options.

## **Research Methodology**

Research methodology introduces a framework through which knowledge is acquired, tested, and refined. It acts as the guide, which researchers use for going through the complicated path of research, which guarantees validity, clarity, and consistency of discovered results. In general, research methodology refers to the systemic approach used to investigate research questions, gather data, analyze information, and finally draw meaningful conclusions.

The particular research includes the convergent mixed methodology, employing both quantitative and qualitative research approaches. The research question for the particular research is as follows: What are the factors that effect on consumer's attitude towards green packaging in food and beverage industry in Sri Lanka? The deductive approach uses quantitative measurements to produce hypotheses about independent and dependent variables. The eight generated hypotheses in this study were measured using regression analysis, correlation analysis, and descriptive analysis.

To survey a pre-selected sample, the researcher used an efficient questionnaire in survey methodology. In a quantitative study, surveys of a representative sample of the public were utilized to characterize the attitudes, opinions, behaviors, and other characteristics of the population concerning the Consumer behavior on green packaging. Regression, correlation, and descriptive analytic approaches are used to investigate an online questionnaire with twenty five closed-ended items in the study's second, quantitative component.



The researcher evaluated the collected data using SPSS Version 25. The goal of the descriptive analysis is to provide insight into the degree to which each variable is involved. The degree of involvement was ascertained by calculating the mean value that resulted from the data analysis using SPSS.

A reliability test was carried out to ensure that the criteria under consideration were internally consistent. Values more than 0.9 in Cronbach's alpha imply good consistency, more than 0.7 reliable variables, and more than 0.6 acceptable variables. The correlation analysis is then used to determine the link between the independent and dependent variables. In order to ascertain the impact of the independent factors on the dependent variable, regression analysis will be conducted.

To gather primary data, the researcher conducted structured interviews with the selected respondents. By using a likert-scale questionnaire, the researcher was able to collect data from the sample in a prepared manner and explore the diverse perspectives and experiences of users regarding the connection between social media marketing and customer loyalty. Apart from collecting primary data, the researcher meticulously perused scholarly articles and studies that were made available online. By situating our study within the body of recent literature and providing a framework for comparison with the ideas gleaned from the interviews, this secondary data offers a more thorough contextual perspective.

The well-crafted questionnaire for this study was designed to elicit detailed and incisive feedback from a selection of telecommunications firm customers. Carefully developed questions investigated customer attitudes regarding green packaging. Using this hybrid research approach, the researcher can discover not just quantitative data but also underlying qualitative information that influences their thoughts, allowing them to capture the depth of customer insights. Understanding the crucial role that consumers play in formulating and implementing organizational plans, this study intentionally focuses on customers who visit the main customer service offices of three large food and beverage companies in Sri Lanka during a day. Accordingly, the identified number of population is 95.

The study sample for the quantitative component of this research project is made up of existing clients from three large food and beverage firms. A random sampling technique was utilized to choose these specific respondents, ensuring a diverse representation of the important players in the food and beverage business. The justification for this decision arises from the realization of the critical influence of top industry players that are heavily involved in the competition are fast adopting innovative green concepts to attract new clients.

The quantitative part of the research has been carried out with the expert interviews and the sample size was 05. The sample has been selected upon the recommendations of the officials of selected companies. The company employees have offered great insights about the consumer behavior towards green packaging. Select experts with diverse backgrounds relevant to consumer behavior and green packaging from the selected three food and beverages companies. This included marketing professionals, sustainability consultants, and representatives from packaging industry associations. Then the following questions were developed for interviews:

- Perceptions of consumer attitudes towards green packaging.
- Factors influencing consumer choices related to green packaging.
- Emerging trends in consumer behavior and green packaging preferences.
- Strategies for businesses to design and market green packaging effectively.

Then a pilot interview has been conducted and the results was obtained as expected and the thematic analysis were conducted finally. Thematic analysis provides a flexible framework for exploring complex



phenomena. By systematically examining interview transcripts, researcher identified patterns in experts' perspectives. These patterns represent recurring themes, conceptual categories that capture the essence of experts' discussions.

Thematic analysis involves several key steps. Coding is the initial stage, where the researcher assigns codes to segments of text in the transcripts. These codes capture key concepts mentioned by the experts. Following this, the researcher groups similar codes into emerging themes. Thematic analysis can be inductive, where themes emerge organically from the data, or deductive, where the researcher has a pre-existing set of themes to explore.

## Results

This research investigated consumer behavior towards green packaging, employing a mixed-methods approach that combined qualitative and quantitative analyses. The qualitative phase, involving interviews with five experts, aimed to identify key influencing factors. Product value perception, consumer awareness, eco-friendly production process, and packaging functionality emerged as the four main themes. The researcher constructed a conceptual framework and conducted a quantitative analysis to explore the statistical relationships between the identified factors and consumer behavior towards green packaging. A five-point Likert scale questionnaire was distributed to a sample of 78 customers from selected supermarket outlets. The quantitative analysis yielded significant findings, revealing statistically positive relationships between all four independent variables (product value perception, consumer awareness, eco-friendly production process, and packaging functionality) and the dependent variable (consumer preference for green packaging).

However, a closer look at the results suggests varying degrees of influence. The analysis using SPSS software revealed that "eco-friendly production process" had the strongest positive correlation (coefficient of 0.637) with consumer preference for green packaging. This suggests that consumers are increasingly prioritizing a company's commitment to environmental responsibility throughout the entire product lifecycle, including packaging production. Companies can leverage this insight by investing in sustainable production practices and transparently communicating these efforts to environmentally conscious consumers.

Following closely behind was "product value perception" with a coefficient of 0.583. This indicates that consumers' overall perception of the value proposition of green packaging, encompassing its environmental benefits and potential impact on product quality, plays a significant role in their purchasing decisions. Companies can address this by ensuring clear communication about the benefits of green packaging materials and dispelling any concerns about their effectiveness.

"Consumer awareness" obtained a coefficient of 0.549, highlighting its positive influence. Informed consumers who understand the environmental benefits of green packaging are more likely to choose it. Companies can prioritize educational initiatives to raise awareness about the environmental impact of traditional packaging and the advantages of green alternatives.

"Packaging functionality" had the lowest coefficient (0.546) but still demonstrated a statistically significant positive relationship. While core functionalities like protection and freshness preservation remain important, consumers are increasingly open to green packaging options that deliver on these essential aspects. Companies can prioritize research and development of innovative, eco-friendly materials with superior performance and functionality, ensuring green packaging remains competitive in the marketplace.



## Conclusions

This research investigated consumer behavior towards green packaging, employing a mixed-methods approach that yielded valuable insights. The qualitative analysis identified four key influencing factors: product value perception, consumer awareness, eco-friendly production process, and packaging functionality. The subsequent quantitative analysis confirmed statistically significant positive relationships between all four factors and consumer preference for green packaging. The analysis revealed varying degrees of influence, with eco-friendly production processes emerging as the most impactful factor.

These findings suggest that a multi-faceted approach is crucial for companies seeking to promote green packaging adoption. By prioritizing sustainable production practices throughout the lifecycle and communicating these efforts transparently, companies can address the growing consumer demand for environmental responsibility. Furthermore, ensuring clear communication about the value proposition of green packaging materials, including their environmental benefits and impact on product quality, can positively influence consumer perception. Additionally, educational initiatives can raise consumer awareness about the environmental impact of traditional packaging and the advantages of green alternatives.

While core functionalities like protection and freshness preservation remain essential, consumers are increasingly open to green packaging options that deliver on these aspects. Companies can address this by investing in research and development of innovative, eco-friendly materials with superior performance and functionality. By considering this combination of factors – environmental responsibility, product value perception, consumer awareness, and core functionalities – companies can develop green packaging solutions that resonate with a wider range of consumers and contribute to a more sustainable future.

## References

- Igbomor, E. (2024). The effect of green packaging on consumers buying behavior. *Ekonomika a spoločnosť*, 25(1), 111-123. <http://dx.doi.org/10.24040/eas.2024.25.1.111-123>
- Jestratijevic, I., Maystorovich, I., & Vrabič-Brodnjak, U. (2022). The 7 Rs sustainable packaging framework: Systematic review of sustainable packaging solutions in the apparel and footwear industry. *Sustainable Production and Consumption*, 30, 331-340. <https://doi.org/10.1016/j.spc.2021.12.013>
- Lekesiztürk, D., & Oflaç, B. S. (2022). Investigating sustainable packaging practices: A framework approach. *Present Environment and Sustainable Development* 16(1), 171-186. <http://dx.doi.org/10.47743/pesd2022161013>
- Steenis, N. D., Van Herpen, E., Van der Lans, I. A., Ligthart, T. N., & Van Trijp, H. C. M. (2017). Consumer response to packaging design: The role of packaging materials and graphics in sustainability perceptions and product evaluations. *Journal of Cleaner Production*, 162, 286-298. <https://doi.org/10.1016/j.jclepro.2017.06.036>
- Wandosell, G., Parra-Merono, M., Alcayde, A., & Banos, R. (2021). Green Packaging and Consumer Behavior. *Sustainability*, 13(3), 1356. <https://doi.org/10.3390/su13031356>



## **Shimashi Niranthara Samarasekara Naiduwadura. E-COMMERCE STRATEGIES FOR SMALL AND MEDIUM ENTERPRISES IN SRI LANKA**

*EKA University of Applied Sciences  
Master's Study Program "Business Administration"*

*E-mail: shimashi95@gmail.com*

*Scientific Advisor: Dr.oec., Assistant Professor Jevgenija Dehtjare*

### **Abstract**

**Research relevance:** In the today's digital age; e-commerce is becoming increasingly essential for business growth and competitiveness. Sri Lankan SMEs play a crucial role in the country's economy but face challenges in adopting effective e-commerce strategies. This research aims to address these challenges by providing tailored guidelines to help SMEs in Sri Lanka harness the power of e-commerce for sustainable growth and success.

**Research goal:** Is to provide guidelines for e-commerce strategies for Sri Lanka SMEs thus creating practical recommendations for its development.

**Research methods:** surveys and interviews were conducted to gather data on the effectiveness of e-commerce strategies implemented by SMEs. A random sampling method was employed to select 187 customers in Colombo; Kurunegala; and Kandy areas in Sri Lanka to ensure diverse perspectives. Data were collected through structured questionnaires and interviews with five SME entrepreneurs. Data processing involved Reliability Analysis; Regression Analysis; Correlation analysis; Content Analysis; hypotheses testing

**Main findings:** the study reveals that effective e-commerce strategies can significantly enhance online visibility; boost sales revenue for SMEs; and improve competitiveness in the market. Implementing these strategies is crucial for the sustainable growth and success of Sri Lankan SMEs in the digital era.

*Keywords: e-commerce; small and medium enterprises (SMEs); strategy; digital sales.*

### **Introduction**

The topicality of research is today's digital age, e-commerce is becoming increasingly essential for business growth and competitiveness. Sri Lankan SMEs play a crucial role in the country's economy but face challenges in adopting effective e-commerce strategies. This study aims to address these challenges by providing tailored guidelines to help SMEs in Sri Lanka harness the power of e-commerce for sustainable growth and success. In Sri Lanka, Small and Medium Enterprises (SMEs) play a vital role in the economy, contributing significantly to employment, innovation, and economic growth. However, many SMEs face challenges in reaching wider markets and maximizing their potential due to limited resources and traditional business practices. Embracing e-commerce strategies presents a promising opportunity for SMEs to overcome these obstacles and thrive in the digital age.

The aim of this research is to provide guidelines for e-commerce strategies for Sri Lanka SMEs thus creating practical recommendations for its development. Major identified data collection methods are Survey and interviews. Data Processing and Interpretation Methods: Reliability Analysis, Regression Analysis, Correlation analysis, Content Analysis, hypotheses testing. The Novelty of this study is There



is a novel approach with the introduction of hyper personalization which is known to be latest E-commerce strategy for Small and Medium Level Enterprises as they are newly moving to a digital path in order to keep the business sustainable in the industry and The Strategies which are related to user-generated content (UGC) are new in their environment and do have to adapt for both e-commerce and e-commerce strategies.

The developed hypotheses will be testing and how the particular research will positively influence on the target aim will be described briefly through the hypothesis.

H1: Establishment of strong website has an impact on the successful e-commerce operation in SMEs

H2: Developing effective e-commerce strategies has an impact on the successful e-commerce operation in SMEs

H3: Strategy which increases consumer service has an impact on the successful e-commerce operation in SMEs

H4: Proper implementation effective e-commerce strategy has an impact on the successful e-commerce operation in SMEs.

From this research, the researcher identified that in order to develop impactful guideline for the e-commerce strategy implementation, Strong web site, Effective strategy, Online customer service, and Proper implementation of E-commerce strategy are important and they do have positive impact and relationship on the successful e-commerce platform implementation

As a summary, the major problem identified was, many of the SMEs in Sri Lanka is unaware about the e-commerce strategies which could be utilized in order to enhance their performance level among the target market. As per ADB Asia SME Monitor 2023 Database, the active SMEs are falling under three categories, Industry and Construction, Trade and Services. In the industry and constructions field, number of persons engaged in small enterprises are 5-24 people and medium enterprise do have 25-199. Out of these, 78.32% are not practically getting the use of e-commerce platforms and strategies (Kumarasinghe, 2021). They have no idea how they could improve their business through e-commerce strategies. Compared to industry and construction SMEs, other two categories are using the e-commerce platforms actively. This study is expecting to provide impactful insight about the e-commerce strategies that could be utilized by the SME persons, in order to improve their business in many aspects while minimizing the cost levels.

## **Literature Review**

E-commerce has witnessed significant growth worldwide, transforming the way businesses operate and consumers engage in transactions. Sri Lanka, with its expanding digital infrastructure and increasing internet penetration, is no exception to this trend. This literature review provides an overview of the e-commerce landscape in Sri Lanka, highlighting key trends, challenges, and opportunities for businesses operating in this emerging market.

Sri Lanka's e-commerce infrastructure has undergone notable development in recent years, driven by advancements in technology and increasing internet accessibility. According to the Central Bank of Sri Lanka (CBSL), the country's internet penetration rate stood at 35.7% in 2020, indicating a significant portion of the population with access to online platforms (CBSL, 2021).



E-commerce offers numerous benefits for SMEs, enabling them to overcome traditional barriers to market entry and expansion. One of the key advantages is the ability to reach a broader customer base beyond geographical boundaries. By establishing an online presence, SMEs can access national and international markets, reaching customers who may not be reachable through traditional brick-and-mortar stores (Perez & Rodrigo, 2020). Technological advancements and innovations have revolutionized e-commerce, making it easier for businesses to set up online stores, process transactions, and engage with customers. Features such as mobile shopping apps, AI-driven recommendation engines, and secure payment gateways enhance the user experience and drive adoption by providing seamless and efficient shopping experiences (Chaffey & Ellis-Chadwick, 2019). From the emergence of new platforms to the integration of artificial intelligence (AI) and augmented reality (AR), these innovations have revolutionized how businesses engage with customers and conduct transactions online.

The proliferation of smartphones and mobile devices has fueled the growth of mobile commerce (m-commerce), enabling consumers to shop anytime, anywhere using their mobile devices. Mobile apps and optimized websites offer a seamless shopping experience, allowing users to browse products, make purchases, and track orders on the go. M-commerce has become a significant driver of e-commerce growth, with a growing share of online transactions originating from mobile devices (GSMA, 2021).

A strong e-commerce platform serves as the backbone of online operations. Businesses need to consider factors like scalability, security, and integration capabilities when selecting a platform (Anderson, 2017). Popular platforms like Shopify, Magento, and WooCommerce offer diverse features and functionalities. Choosing a platform that aligns with the business's needs and technical expertise is crucial. Additionally, ensuring secure payment processing and implementing trust signals like security badges and customer testimonials foster customer confidence (Carter & Wright, 2015). The e-commerce website serves as the virtual storefront. User-friendliness reigns supreme, with intuitive navigation, clear product categories, and a well-functioning search bar being essential. High-quality product images, detailed descriptions, and customer reviews provide transparency and build trust (Zhang et al., 2014). A responsive design ensures optimal viewing and functionality across various devices, catering for the mobile-first browsing habits of consumers.

Reaching the target audience and driving sales require effective marketing strategies. Search engine optimization (SEO) and content marketing are crucial for attracting organic traffic (Chaffey & Ellis-Chadwick, 2019). Utilizing relevant keywords, optimizing website content, and building backlinks improve search engine ranking, making the website more discoverable. Social media marketing, email marketing, and influencer marketing can further amplify a brand's reach and connect with potential customers (Huang et al., 2014). Efficient logistics and fulfillment operations are paramount for delivering products promptly and cost-effectively (Stock et al., 2013). Businesses must consider shipping options, inventory management strategies, and potential partnerships with fulfillment service providers. Exceptional customer service is essential for building customer loyalty and repeat business. Providing multiple communication channels, responsive support systems, and fostering positive online reviews contribute to a positive customer experience.

Further, Sri Lanka's e-commerce landscape has been steadily growing, driven by increasing internet penetration and smartphone usage. The COVID-19 pandemic further accelerated the shift towards online shopping, highlighting the importance of digital platforms for businesses. Despite this growth, SMEs in Sri Lanka have been slow to adopt e-commerce due to various barriers, including limited digital literacy, inadequate infrastructure, and concerns about online security. To capitalize on the benefits of e-commerce, SMEs in Sri Lanka can implement several strategies tailored to their specific needs and capabilities (Kumarasinghe, 2021).



While e-commerce presents significant opportunities for SMEs in Sri Lanka, several challenges need to be addressed to facilitate broader adoption. These include improving digital infrastructure, addressing cybersecurity concerns, and providing adequate training and support for SMEs to navigate the digital landscape. Government initiatives, private sector partnerships, and educational programs can play a crucial role in overcoming these challenges and empowering SMEs to thrive in the digital economy.

E-commerce offers immense potential for Small and Medium Enterprises in Sri Lanka to expand their reach, increase competitiveness, and drive economic growth. By embracing e-commerce strategies tailored to their needs and capabilities, SMEs can overcome traditional barriers and seize new opportunities in the digital age. With the right support and investment, SMEs can play a pivotal role in shaping Sri Lanka's digital future and contributing to sustainable development. In this backdrop, the identified most potential research work is topical as “E-Commerce Strategies for Small and Medium Enterprises in Sri Lanka” and expecting to develop practical guidelines for enhancing e-commerce strategies tailored to SMEs in Sri Lanka.

### **Research Methodology**

The research approach adopted for this study will be a multifaceted approach, combining both quantitative and qualitative methods to gain a comprehensive understanding of e-commerce strategies for SMEs in Sri Lanka. This approach acknowledges the complexity of the topic and the importance of considering both the statistical trends and the lived experiences of stakeholders within the Sri Lankan e-commerce ecosystem.

Semi-structured interviews will be conducted with SME customers in Sri Lanka. This method allows for flexibility and probing into specific aspects of their e-commerce journeys, including challenges faced, decisions made, and strategies implemented. Interviews with e-commerce specialists, marketing professionals, and representatives from government agencies and logistics providers will provide valuable insights from different perspectives within the e-commerce ecosystem. Facilitating focus groups with Sri Lankan consumers who actively engage in online will shed light on their preferences, motivations, and pain points when purchasing from SMEs online. This will inform the development of e-commerce strategies that cater to customer expectations and enhance the online experience.

The deductive technique use quantitative measurements to generate hypotheses regarding independent and dependent variables. The eight hypotheses generated in this study were tested using regression, correlation, and descriptive analysis. This analysis method will also be applied in the current investigation. To survey a pre-selected sample, the researcher employed an effective questionnaire in survey methodology. A quantitative study used surveys of a representative sample of the public to characterize the population's views, opinions, actions, and other features about consumer behavior on green packaging. The second quantitative component of the study employs regression, correlation, and descriptive analytic tools to explore an online questionnaire with twenty-four closed-ended questions.

The researcher used SPSS Version 25 to assess the acquired data. The descriptive analysis seeks to provide insight into the extent to which each variable is involved. The degree of engagement was determined by computing the mean value obtained from the data analysis using SPSS. A reliability test was conducted to confirm that the criteria being considered were internally consistent. Cronbach's alpha values greater than 0.9 indicate strong consistency, more than 0.7 dependable variables, and more than 0.6 acceptable variables. Correlation analysis is then utilized to establish the relationship between the independent and dependent variables. To determine the impact of the independent factors on the

dependent variable, regression analysis will be used. Further 05 expert interviews have been conducted to improve the insights of the research qualitatively.

In a mixed-methodology research approach, data analysis involves integrating and analyzing both quantitative and qualitative data to gain a comprehensive understanding of the research topic or question. For the particular research, the analysis of data on the E-commerce strategies of SMEs in Sri Lanka have been carried out. The quantitative data and qualitative data has been gathered for research and quantitative data is analyzing with the reliability analysis, descriptive analysis, regression analysis and correlation analysis. This shows the relationship and impact between independent and dependent variables. The qualitative data will be analyzed thematically. It starts the coding process by systematically identifying and labeling meaningful segments of the data. These codes capture key ideas, concepts, or topics present in the data. Codes can be descriptive or interpretive, capturing both surface-level content and underlying meanings. Once initial coding is complete, organize related codes into potential themes. Look for patterns, similarities, or connections among codes that suggest broader concepts or topics. Themes should represent significant aspects of the data that are relevant to the research question or objectives. Review the identified themes in relation to the coded data. Ensure that each theme is coherent, internally consistent, and distinct from other themes. Refine and adjust the themes as needed, merging or splitting them to accurately capture the richness of the data. Write a narrative or report that presents the findings of the thematic analysis which describes each theme in detail, providing illustrative examples from the data to support the interpretations.

## Results

Thematic analysis of expert interviews yielded a conceptual framework that highlights the key factors influencing the successful implementation of e-commerce strategies for Sri Lankan SMEs. This framework positions four independent variables, Strong Website, Effective Strategy, Online Customer Service, and Proper Implementation, as critical elements contributing to the dependent variable: successful e-commerce implementation.

Strong Website represents a user-friendly and informative online platform that showcases products effectively, streamlines the checkout process, and maintains a consistent and professional design. A well-designed website fosters trust and creates a positive first impression, encouraging customer engagement and ultimately driving sales. Effective Strategy signifies a well-defined roadmap for the e-commerce venture. This encompasses having a clear understanding of target markets and sales goals, prioritizing customer needs and adapting to industry trends, and ensuring user-friendly platform operation for both customers and staff. A well-defined strategy allows Sri Lankan SMEs to operate with a purpose, navigate the dynamic e-commerce landscape, and remain competitive in the online marketplace. Online Customer Service emphasizes the importance of prioritizing customer experience throughout the online shopping journey. This involves providing readily accessible support channels, employing well-trained representatives with a focus on customer satisfaction, offering comprehensive resources, and ensuring a user-friendly platform for both customers and staff. A robust online customer service system fosters trust, builds customer loyalty, and encourages repeat business, ultimately contributing to the success of the e-commerce venture.

Proper Implementation signifies a well-executed launch phase. This involves having a reliable technical support team in place, ensuring a well-trained workforce can manage the platform and interact with customers effectively, implementing strategies to build customer awareness about the new online store, and selecting an e-commerce platform that is compatible with the Sri Lankan technological landscape.



A smooth and well-planned implementation lays the foundation for a successful e-commerce venture and minimizes potential disruptions during the launch phase.

This research delved into the critical factors influencing the successful implementation and operation of e-commerce ventures for Sri Lankan SMEs. Employing a mixed-methods approach, the study combined qualitative and quantitative analyses to gain comprehensive insights into this dynamic landscape. The qualitative phase, consisting of five expert interviews, identified four primary factors that emerged as crucial for e-commerce success: strong website, effective strategy, online customer service, and proper implementation. These factors formed the foundation for the subsequent quantitative analysis.

The quantitative analysis, utilizing a five-point Likert scale questionnaire administered to 187 e-commerce customers, examined the statistical relationships between the identified factors and successful e-commerce operation. The results provided compelling evidence, with all four factors exhibiting statistically significant positive correlations with successful e-commerce implementation. Among these factors, "effective strategy" emerged as the most impactful, demonstrating the strongest correlation with successful e-commerce operation. This highlights the vital role of a well-defined, adaptable, and data-driven strategy in navigating the complexities of the online marketplace. A robust strategy provides a clear roadmap for business goals, target audience identification, marketing initiatives, and operational procedures, ultimately contributing to a higher likelihood of success. Following closely behind was "strong website," emphasizing the importance of a user-friendly, informative, and visually appealing online storefront. A well-designed website fosters trust, facilitates product discovery and navigation, and streamlines the customer journey, leading to higher conversion rates and customer satisfaction.

"Online customer service" secured the third strongest positive correlation, underlining the critical role of providing efficient and positive customer service experiences. Offering multiple contact channels, employing knowledgeable representatives, and prioritizing prompt issue resolution are crucial for building customer trust, loyalty, and repeat business. "proper implementation" demonstrated a statistically significant, albeit slightly lower, correlation with successful e-commerce operation. This signifies the importance of a well-executed launch phase, encompassing factors like technical support, team training, and effective marketing strategies. Ensuring a seamless transition to online operations minimizes disruptions, builds customer confidence, and lays the groundwork for long-term success.

The research identified four key factors, effective strategy, strong website, online customer service, and proper implementation, that hold significant influence on the successful operation of e-commerce ventures for Sri Lankan SMEs. The researcher used SPSS Version 25 to assess the acquired data. The descriptive analysis seeks to provide insight into the extent to which each variable is involved. The degree of engagement was determined by computing the mean value obtained from the data analysis using SPSS. A reliability test was conducted to confirm that the criteria being considered were internally consistent. Cronbach's alpha values greater than 0.9 indicate strong consistency, more than 0.7 dependable variables, and more than 0.6 acceptable variables. Correlation analysis is then utilized to establish the relationship between the independent and dependent variables. To determine the impact of the independent factors on the dependent variable, regression analysis will be used. Further 05 expert interviews have been conducted to improve the insights of the research qualitatively.

## Conclusions

This research delves into the multi-faceted approach necessary for successful e-commerce operation within Sri Lankan SMEs. By employing a mixed-methods approach, the study sheds light on the crucial factors that contribute to a thriving online presence. The findings highlight the interconnectedness of



four key elements: strong website, effective strategy, online customer service, and proper implementation. While each factor plays a distinct role, the research emphasizes the importance of a well-defined and adaptable e-commerce strategy. This acts as the guiding force, shaping target audience identification, marketing initiatives, and operational procedures, ultimately leading to a higher likelihood of success. A user-friendly and visually appealing website is paramount in fostering trust, facilitating product discovery, and streamlining the customer journey. This translates to higher conversion rates and customer satisfaction, solidifying the online presence of the SME. Prioritizing efficient and positive online customer service emerges as another critical factor. Providing multiple contact channels, employing knowledgeable representatives, and prioritizing prompt issue resolution fosters trust and loyalty, ultimately contributing to repeat business and a sustainable customer base. The research further underscores the significance of proper implementation. A smooth and well-executed launch phase, encompassing technical support, team training, and effective marketing strategies, minimizes disruptions, builds customer confidence, and lays the groundwork for long-term success in the dynamic e-commerce landscape.

In conclusion, this research presents a multi-faceted framework for Sri Lankan SMEs to navigate the e-commerce landscape successfully. By prioritizing and strategically integrating these four key factors – strong website, effective strategy, online customer service, and proper implementation – Sri Lankan SMEs can maximize their potential to thrive in the competitive world of online commerce while contributing to a more sustainable future.

## References

- Anderson, D. (2017). *E-commerce strategy: Break through the noise and build a digital business that scales*. Palgrave Macmillan
- Carter, L., & Wright, M. (2015). *Omnichannel retailing*. Kogan Page Publishers
- Chaffey, D., & Ellis-Chadwick, F. (2019). *Digital marketing & e-commerce strategy*. Pearson
- Chaffey, D., & Ellis-Chadwick, F. (2019). *Digital marketing: Strategy, implementation and practice*. Pearson
- Huang, Z., & Benyoucef, M. (2015). From e-commerce to social commerce: A close look at design features. *Electronic Commerce Research and Applications*, 14(4), 214-230. <http://dx.doi.org/10.1016/j.elerap.2012.12.003>
- GSMA. (2021). *The mobile economy*. [https://www.gsma.com/solutions-and-impact/connectivity-for-good/mobile-economy/wp-content/uploads/2021/07/GSMA\\_MobileEconomy2021\\_3.pdf](https://www.gsma.com/solutions-and-impact/connectivity-for-good/mobile-economy/wp-content/uploads/2021/07/GSMA_MobileEconomy2021_3.pdf)
- Novak, T. P., Hoffman, D. L., & Yung, Y.-F. (2020). Measuring the customer experience in online environments: A structural modeling approach. *Marketing Science*, 19(1), 22-42. <https://doi.org/10.1287/mksc.19.1.22.15184>
- Perez, M., & Rodrigo, P. (2020). The effects of e-commerce on SMEs performance. *Journal of Small Business Strategy*, 30(1), 15-26.
- Zhang, W., Zhang, F., Zhang, J., Zhang, J., & Zhang, J. (2018). Research and analysis on the identification model of multivariate economic system. *IOP Conference Series: Materials Science and Engineering*, 452, 022061. <https://doi.org/10.1088/1757-899x/452/2/022061>





## **Aswathy Levan. ASSESSMENT OF RELATIONSHIP MARKETING AS A TOOL TO IMPROVE THE COMPETITIVENESS OF LATVIAN WOOD SELLING COMPANIES**

*EKA University of Applied Sciences*

*Master's Study Program "Business Administration"*

*E-mail: levanaswathy@gmail.com*

*Scientific Advisor: Dr.oec., Assistant Professor Jevgenija Dehtjare*

### **Abstract**

**Research relevance:** Particularly in exports of wood and wood products; Latvia has a considerable position in the wooden sector. The competitiveness of this industry can be considerably impacted by the application of cutting-edge technologies and successful relationship marketing. Innovative technology and relationship marketing play a critical role in Latvia's wooden sector; which contributed about 7% of the nation's GDP in 2020. Understanding how technology and customer relationships promote growth is essential for maintaining Latvia's wooden company success as global competition heats up.

**Research goal:** To assess the relationship marketing as a tool to improve competitiveness of Latvian wood selling companies.

**Research methods:** Previous literatures; and survey analysis; are among the data collection approaches. To measure the impact of relationship marketing on the competitiveness of wood selling companies; data processing methods include various mathematical analyses; factor analysis; descriptive statistical analysis; and correlation.

**Main findings:** The competitiveness of businesses in Latvia that deal in selling wood is significantly improved by the use of relationship marketing tactics. This might result in enhanced brand impression; increased consumer loyalty; and higher rates of client retention. The relationship marketing efforts made by Latvian wood selling enterprises are perceived by their consumers. This might involve gaining insights on what customer's value most in their encounters with these firms and how it effects the purchase decisions they make.

*Keywords: relationship marketing; competitiveness; wood selling companies; customer loyalty.*

### **Introduction**

The global marketplace is becoming an increasingly competitive environment, and organizations operating in a wide range of sectors are consistently looking for new methods to obtain a competitive advantage. In this context, the function of relationship marketing has gained substantial attention as a strategic tool to increase the competitiveness of organizations, particularly those operating in specialized niches like as the Latvian wood-selling sector. Specifically, this emphasis has been focused on the role of relationship marketing as a strategic tool to improve customer satisfaction and retention. Given that Latvia is a nation that is abundant in forest resources and has a long-standing heritage of wood processing and trading, the performance of the country's firms that deal in the sale of wood is an essential component in determining the country's economic growth and its level of global competitiveness.



Establishing and maintaining long-term connections with consumers, suppliers, and other stakeholders may lead to sustained success is at the core of the concept of relationship marketing. As for gaining a competitive edge, relationship marketing places a strong emphasis on retaining customers, rewarding their loyalty, and ensuring their happiness. The strategic approach is based on the concept that in an era in which many products and services are comparable to one another, the quality of the connections a firm develops and maintains is what separates it from other businesses in the same industry.

On the international market, possibilities and problems that are exclusive to Latvian wood-selling businesses stand out like a sore thumb. Raw material availability is one area in which Latvia has a competitive edge thanks to the country's abundant and environmentally friendly forestry resources. On the other hand, these businesses have to deal with the dynamics of the global market, as well as worries about the environment, changing quality standards, and shifting customer tastes, all of which may put a tremendous amount of pressure on their ability to compete. Relationship marketing has the potential to be an effective strategy in the context of the wood-selling sector in Latvia for a number of reasons. To begin, the market for wood is extremely specialized and frequently determined by the existence of long-term business ties. This is because consumers are constantly searching for dependable suppliers of high-quality wood goods. Second, the sector is susceptible to a wide variety of legal, environmental, and ethical constraints, all of which call for a more sophisticated and environmentally responsible approach to conducting business. Third, the movement toward environmentally friendly and sustainable goods that has taken place all over the world has presented wood merchants in Latvia with a big chance to rebrand themselves as dependable and responsible providers.

The purpose of this study is to evaluate the contribution that relationship marketing may make to increase the competitiveness of wood-selling businesses in Latvia. This study will investigate how these businesses might make use of relationship marketing tactics in order to create and sustain good connections with a variety of stakeholders, such as consumers, suppliers, and industry partners. The influence that relationship marketing has on key performance measures like as customer loyalty, market share, and profitability will also be investigated as part of this study project. In addition, this study will investigate the obstacles and prospects that Latvian wood-selling businesses encounter while attempting to effectively apply relationship marketing tactics. This study will investigate the degree to which relationship marketing may provide solutions to these problems and make a contribution to the further expansion and viability of the business.

## **Literature Review**

A research that have three parts and centered on the strategic ramifications of the variety and unpredictability of consumers' needs and wants. In order to meet the needs of customers who have varying tastes and to offer a level of vertical differentiation, a company's primary objective is to develop add-on policies. This hypothesis not only explains the seemingly counterintuitive occurrence in which higher-end hotels are more likely to charge for Internet connection than lower-end hotels, but it also makes the prediction that selling an add-on as an optional service enhances competition. This hypothesis was developed to explain the situation in which higher-end hotels are more likely to charge for Internet access than lower-end hotels (Balocco et al., 2010). This discovery runs counter to the prevalent thinking that can be gleaned from the study done on this subject.

In a study, one of the goals of the research is to take a more in-depth look at the role that B2B e-Marketplaces play in supporting B2B relationships, as well as to identify successful business models and the critical success factors (CSFs) related to those models, and then to propose a new classification



framework for e-Marketplace business models (Karavidic & Gregory, 2005). The foundation of this research was a case study that looked at 30 online marketplaces located all over the world. The findings of the article indicate that there are nine distinct business models that have been found. Each of these business models may fall into a distinct category depending on the service delivery model that it employs as well as the associated procedures that it implements within businesses (Moorman et al., 2019).

The authors researched the history of the interpersonal connection metaphor in marketing, analyzed the rhetorical uses of the metaphor, and proved that the marketing as connections frame has been lexicalized in order to carry out the research for the study (Biswas, 2014). When the frame was investigated in both the theoretical and practical contexts of this study, the findings indicated that it was regarded as being unsuitable and meaningless in both of these settings (Smith, 2011). The authors revealed that there are considerable disparities between the exchanges that take place on a mass scale and those that take place between two individuals in a one-on-one setting. The investigation of RM cannot be carried out via the prism of conceptual metaphor. In spite of this, they devised creative answers to the issues that needed to be addressed (Tooranalo & Saghafi, 2019).

The number of academics as well as industry professionals interested in the connections that exist between customers and the brands that they use has been increasing. The perspectives vary on this matter. In addition to structural equation modeling, exploratory research and a cross-regional survey are carried out in order to evaluate the overall model structure and the causal path pattern that is given by the model for the Strategic Management of Service Brand Relationships. This is done so that the model may be used to better manage the relationships between service brands. In addition, each of the eight connection components has a direct influence on the degree of brand loyalty exhibited by the client in response to the service.

According to other research findings, the purpose of the article is to provide a model that is intended to merge pre-existing concepts on export marketing with e-commerce. To be more specific, the objective is to develop a theory that accomplishes the following: (a) incorporates e-commerce strategy into previously established export marketing theories; (b) proposes a contingency approach to compare and contrast the relationship between environmental variables, export market strategy, and export performance; and (c) provides a clear direction for future research by making research propositions about the role that e-commerce strategy plays in the process of exporting (Agarwal et al., 2010).

In addition, another study delves quite deeply into a variety of customer relationship management (CRM)-related topics, including the concept and context of CRM, various types of customers and the values that they place importance on, customer relationship management technology, the management of customer relationships, consumer research, strategy, measurement, and human resource management in CRM. This publication presents a number of different case studies and examples that are taken from a diverse assortment of business fields. There are several distinct service verticals that are included in this coverage, including as banking, retail, telecommunications, aviation, and electronic media, among others. Reading this book may be beneficial for a number of different people, including students, practitioners, and managers, because it provides information on how important it is to connect with consumers (Christopher et al., 2013).

In order for businesses to maintain their advantage in a market that is extremely competitive, they need to consistently focus their attention on identifying differentiated product strategies, building or reorganizing core competencies, and gaining skills in human resources and technology that are unique to them. These are all things that may be used to one's advantage in order to advance one's business. In addition, a rise in customer value can be done by delivering a lower price or by supplying extra goods and services that justify equivalent, or possibly even larger, expenditures (Porter, 2015). Both of these



strategies have the ability to raise the value of the customer to the business. One school of thought maintains that a competitive advantage can be considered long-term if it can continue to enjoy that advantage regardless of what its competitors do (Amain, 2020).

In a separate piece of research, the authors found that when a company's service or product provides clients with the same or higher advantages at a reduced cost, or when the company's product exceeds the benefits, this may be a substantial source of competitive advantage for the firm in issue. Business schools such as the Wharton School and the Harvard Business School have an inherent advantage over other business schools owing to the fact that they are rated in the top three among all business schools, they have large endowments, and their names are well-known in the business world. This gives these institutions a competitive edge that is not easily replicated by other business schools. There are a lot of schools that teach small business, but most of them don't have their own endowments, so it might be difficult for them to get appropriate finance and other resources (Boateng, 2019).

As for the majority of marketing decisions that have a substantial impact on the market, they are subject to relative and absolute considerations. For example, the prices that are set by rivals in the market are what determine whether or not a certain pricing structure is desirable to buyers. When making an effort to gain a more favorable position in the market, one of the obstacles that comes together with marketing is the fact that it is not unusual for a competitor to quickly reply with some type of countermove. This is one of the challenges that comes along with marketing (Kanagal & Kanagal, 2009). With the possible exception of an increase in primary demand, the countermove totally nullifies the effects of the prior move. If one had been made aware of the immediate countermoves, it is quite likely that they would not have carried out many of the actions that were planned to increase market share as well as sales and earnings. As a consequence of this, it is very necessary to have an awareness of the competitive marketing behavior of one's rivals in order to forecast the sort of a competitive reaction to one's marketing efforts as well as the chance of such a reaction occurring (Wang et al., 2011).

The competitive strategy of a firm is a comprehensive and long-term plan that enables a company to gain a competitive advantage on the market. This is a direct result of the decisions that were taken by corporate executives, marketing managers, and a great number of other decision makers. According to the study that has been done, strategy, marketing strategy, and competitive marketing strategy are the primary factors that lead to the creation of specific distinctive propositions that may be utilized to gain a competitive advantage in the market space. The factors acknowledged for competitive marketing strategy include the product, pricing, promotion, technical services, accounting technique, and credit policy. The companies are responsible for delivering these aspects (Wu et al., 2010).

One of the most important advantages of Latvia is enormous forested regions, which cover more than half of the nation's surface. Latvia is the fourth most wooded country in Europe, behind countries such as Finland, Sweden, and Slovenia. This is one of the most significant benefits that Latvia possesses. The composition of Latvia's forests is predominantly made up of deciduous trees, namely birch, which has seen a substantial growth over the entirety of the nation over the course of the last few years. The ownership of forested land in Latvia is significantly fragmented, with many levels of government, including the state and local governments, as well as a large number of private landowners holding a part in the business. Due to the fact that forest land is so widely dispersed, the typical size of a forest property is around 10.6 hectares (Karro et al., 2017). The wood sector in Latvia is up against a number of challenges as well as opportunities. Currency fluctuations have an effect on the fluctuation of imports from the United States, which in turn has an effect on the decisions that Latvia takes on its imports, which are heavily influenced not just by currency concerns but also by the logistical costs involved. In recent years, there has been an increase in the amount of hardwood timber that has been imported into Europe from the USA. On the other hand, there has been a drop in the amount of panel products that

have been imported from the United States as a consequence of increased competition from other suppliers in the European market (Mira, 2016).

Since the beginning of the economic downturn in the years leading up to 2010, the wood and wood products industry in Latvia has seen a meteoric rise in terms of both its recovery and its development trajectory. This rebound may be ascribed, at least in significant part, to a number of different causes, including enhanced competitiveness, the possibility for export, and diversification into a number of other product categories. Yet, Latvia has established itself as a leading player in the woodworking industry across Europe. This is largely attributable to the country's wide forestland and diverse woodworking sector. Throughout the entirety of the process of economic growth, the European Union (EU) has served as the most important trading partner (Bardule, et al., 2020). The expansion of international trade, and notably exports, has been one of the most important drivers of economic growth. Although challenges such as currency instability and competitive pressures continue to exist, the wood industry in Latvia continues to expand and adapt to changing market dynamics (Bamwesigiye et al., 2023). Therefore, the wood industry continues to be a vital component of the economy of the nation.

### Research Methodology

Research methodology refers to the process stage which explains how the research was conducted. This research study follows a specific way of study. The research aims to identify the impact of relationship marketing on key performance indicators, such as customer loyalty, market share, and profitability, within the Latvian wood selling sector. This study is being carried out in the context of the wood-selling business in Latvia, which is an important part of the country's overall economy. The geographical scope of the study expands to include Latvia, a nation that is well-known for the extensive forest resources it possesses as well as a long-standing legacy of wood processing and commerce.

This research covered a total number of 15 respondents and this sample of 15 respondents was taken anticipating covering the research as planned. Among these wood selling company managers, industry experts and consultants were participated.

**Table 1.** Demographic information of respondents (Source: Created by the author)

Item	Contents	No: of samples	Percentage
Gender	Male	10	64%
	Female	5	36%
Age	28-40	11	76%
	41 and above	4	24%
Job position	Wood selling company managers	9	92%
	Industry experts	6	8%

The primary data was collected from 15 respondents by a questionnaire via convenient sampling methods. As for the data collection and scale validation, all questionnaire items were given on a five-point Likert scale, in which 1 “Strongly agree” and 5 “Strongly disagree”. Since Latvia is national language, But most of the people speak English as well therefore the questionnaires were administered in the English language. A random sampling procedure was used. Since Latvia is a big market for any products and services, this research study is highly significant.

The secondary data was obtained from reports on many different industries, including the wood and forestry industries. These reports tend to be produced by commercial market research agencies. These studies often include information on market size, trends, and a study of the competition. Academic sources are able to provide in-depth study and academic insights on the influence of relationship marketing on competitiveness. Conduct research using academic resources such as PubMed and Google Scholar, as well as databases that are specialized to the subject you are studying.

## Results

There were more females (64%) than males (36%) participating in the research.

### Reliability Analysis

This research employed 8 variants from the survey question to assess the reliability analysis. The main constraints are, Latvian wood selling companies actively engages in building long-term relationships with customers, Companies' customer feedback to tailor products/services to customer needs, Company regularly measure customer satisfaction and act on the results, Company invests in personalized marketing campaigns to cater to individual customer preferences, I Company effectively communicates the company's values and mission to the customers, Company's marketing materials are designed to educate and inform customers, Wood selling company is highly competitive in terms of product quality, company's innovation efforts contribute to our competitiveness.

**Table 2.** Reliability of constraints of relationship marketing strategy (Source: Created by the author)

Cronbach's Alpha	Cronbach's Alpha Based on Standardized Items	N of Items
.754	.792	8

Cronbach's alpha was utilized so that we could determine the extent to which the variables have their own internal consistency. The reliability score for this investigation was 0.754, which is higher than the benchmark of 0.700 and reflects strong dependability as a result of exceeding the threshold.

### KMO and Bartlett's Test

The KMO test has been applied in order to investigate the interrelationship of the restrictions between the data as well as the evaluation of the suitability of the data.

**Table 3.** KMO and Bartlett's Test (Source: Created by the author)

Indicator	Value
Kaiser-Meyer-Olkin Measure of Sampling Adequacy	.613
Approx. Chi-Square	207.13
df	21
Sig.	.000

The KMO value found in this investigation is 0.613, which is greater than the threshold that is advised, indicating that additional study may be carried out if necessary. The degree of freedom is 21, and there

is a significant amount of weight attached to that number. The findings of this survey can thus be utilized in the process of factor analysis.

### Factor Analysis

The essential elements were developed through the use of factor analysis within the SPSS program. The rotation factor matrix was utilized to conduct an analysis of the factors, and the results are presented below along with an explanation of the overall variance. Furthermore, creating strong, long-lasting ties with customers is very important in Latvia's wood-selling business, which is very competitive. Businesses in this field know that building trust, loyalty, and dependability is key to long-term success. Companies that sell wood can build a strong base for return business and word-of-mouth advertising by keeping in touch with customers over a long period of time.

Companies in Latvia that sell wood regularly check to see how satisfied their customers are and act on the information they get in order to stay competitive. This factor shows that the business is dedicated to always getting better. Companies that ask for and act on customer comments can improve their business, meet changing customer wants, and fix any problems that may come up. To be competitive in the wood-selling business, you need to do more than just follow the rules. You also need to be open to new ideas. Companies in Latvia that sell wood know how important it is to stay ahead of the game by coming up with new products, tools, and ways of doing things. These businesses can stand out in a crowded market by putting money into research and development and keeping up with changes in their fields.

**Table 4.** Loaded factors (Source: Created by the author)

Loaded Constraint Factors	Factors
Q1, Q2, Q3	Latvian Wood Selling Companies Actively Engage in Building Long-Term Relationships with Customers
Q4, Q5, Q6	Companies Regularly Measure Customer Satisfaction and Act on the Results
Q7, Q8	Wood Selling Company's Innovation Efforts Contribute to Competitiveness

### Regression Analysis

The outcomes of regression analysis are provided in Table 5.

Table 5 ANOVA. (Source: author's collection)

Model		Sum of Squares	df	Mean Square	F	Sig.
1	Regression	16.481	5	2.051	2.711	.004 <sup>b</sup>
	Residual	54.522	3	.707		
	Total	71.013	8			

a. Dependent Variable: company's innovation efforts contribute to our competitiveness.

b. Predictors: (Constant), Latvian wood selling companies actively engages in building long-term relationships with customers, Companies' customer feedback to tailor products/services to customer needs, Company regularly measure customer satisfaction and act on the results, Company invests in personalized marketing campaigns to cater to individual customer preferences, I Company effectively communicates the company's values and mission to the customers, Company's marketing materials are designed to educate and inform customers, Wood selling company is highly competitive in terms of product quality



Table 5 shows that relationship marketing practices like long-term customer engagement, listening to customer feedback, measuring customer satisfaction, personalized marketing, communicating values, and product quality have a big and statistically significant effect on wood-selling companies' efforts to come up with new ideas that make them more competitive. These results show how important relationship marketing tactics are for making these businesses more competitive in the market.

## Conclusions

This study set out to conduct an in-depth investigation of the role that relationship marketing strategies have in determining how competitive Latvian wood selling businesses are in the global marketplace. The research was conducted in accordance with a particular research methodology, and the primary focus was placed on important aspects related to relationship marketing. These aspects included long-term customer engagement, utilization of customer feedback, satisfaction measurement, personalized marketing, value communication, and product quality competitiveness. The investigation of the information obtained from the 15 responders produced a number of significant discoveries.

According to the findings of the demographic research, the vast majority of respondents were male (64%), aged between 28 and 40 years old (76%), and held crucial positions as managers of wood selling companies (92%). These demographics shed light on the profiles of the people who are taking part in the survey. In order to evaluate the many aspects of relationship marketing, the research made use of a Likert scale. The reliability study revealed that the items in the survey had a high degree of dependability (Cronbach's Alpha = 0.754), which indicates that they are internally consistent. Both the KMO test (0.613) and Bartlett's test (p .001) indicated that the data were suitable for factor analysis.

Through the use of factor analysis, we were able to identify three major elements that play an important part in increasing competitiveness among enterprises selling wood in Latvia. These aspects included the active participation in creating long-term customer connections, the practice of routinely monitoring customer satisfaction and responding on feedback, and the dedication to innovation activities contributing to competitiveness. All of these factors contributed to the company's ability to remain competitive. The relevance of these relationship marketing components taken as a whole was validated by the findings of a regression analysis, which is an extremely important finding. The F-statistic ( $F = 2.711$ ,  $p = .004$ ) revealed that there was a strong and statistically significant influence on the innovation efforts of wood-selling enterprises, which contribute to the companies' levels of competitiveness.

## References

- Agarwal, J., Malhotra, N. K., & Bolton, R. N. (2010). A cross-national and cross-cultural approach to global market segmentation: An application using consumers' perceived service quality. *Journal of International Marketing*, 18(3), 4-10. <https://doi.org/10.1509/jimk.18.3.18>
- Amain, N. N. (2020). The relationship marketing perspective: competitive marketing strategy implementation in improving company performance. *Jurnal Ilmiah Manajemen, Ekonomi, & Akuntansi (MEA)*, 4(1), 453-461.
- Balocco, R., Perego, A., & Perotti, S. (2010). B2B e-marketplaces: A classification framework to analyse business models and critical success factors. *Industrial Management & Data Systems*, 110(8), 1117-1137. <http://dx.doi.org/10.1108/02635571011077799>





- Bamwesigiye, D., Grinbergs, I., Puzule, A., & Kikule, T. (2023). Implications of the nature of forestry and wood enterprises in Latvia. In public recreation and landscape protection-with environment hand in hand? *14th Conference. Mendelova univerzita v Brně*.
- Bardule, A., Jurmalis, A., Libieta, Z., Paulina, I., Donis, J., & Treimane, A. (2020). Use of retail market data to assess prices and flows of non-wood forest products in Latvia. *Silva Fennica*, 54(3).
- Biswas, S. (2014). *Relationship marketing: Concepts, theories and cases*. PHI Learning Pvt. Ltd.
- Boateng, S. L. (2019). Online relationship marketing and customer loyalty: A signaling theory perspective. *International Journal of Bank Marketing*, 37(1), 226-240. <https://doi.org/10.1108/IJBM-01-2018-0009>
- Christopher, M., Payne, A., & Ballantyne, D. (2013). *Relationship marketing*. Taylor and Francis.
- Kanagal, N. B., & Kanagal, N. B. (2009). Role of relationship marketing in competitive marketing strategy. *Journal of Management and Marketing Research*, <https://www.aabri.com/manuscripts/09204.pdf>
- Karavidic, M., & Gregory, G. (2005). Integrating e-commerce into existing export marketing theories: A contingency model. *Marketing Theory*, 75-104. <http://dx.doi.org/10.1177/1470593105049602>
- Karro, E., Kartel, R., & Ceplivovs, A. (2017). Can smart specialization and entrepreneurial discovery be organized by the government? Lessons from Central and Eastern Europe. *Advances in the theory and practice of smart specialization*, 269-29. <http://dx.doi.org/10.1016/B978-0-12-804137-6.00013-9>
- Mira, K. (2016). *Wood sector: Latvia*. Global Agricultural resource network.
- Moorman, C., Van, H. H., Moreau, C. P., & Palmatier, R. W. (2019). Challenging the boundaries of marketing. *Journal of Marketing*, 83(5), 1-4. <http://dx.doi.org/10.1177/0022242919867086>
- Porter, M. (2015). *The competitive advantage of the inner city*. Routledge.
- Smith, M. (2011). *The new relationship marketing: How to build a large, loyal, profitable network using the social web*. John Wiley & Sons.
- Tooranalo, H. S., & Saghafi, S. (2019). Investigating the impact of using knowledge management on organisational agility through competitive intelligence and strategic thinking. *Journal of Information & Knowledge Management*, 18(02). <http://dx.doi.org/10.1142/S0219649219500163>
- Wang, W. C., Lin, C. H., & Chu, Y. C. (2011). Types of competitive advantage and analysis. *International Journal of Business and Management*, 6(5), 100. <http://dx.doi.org/10.5539/ijbm.v6n5p100>
- Wu, C. S., Lin, C. T., & Lee, C. (2010). Competitive marketing strategies decision-making based on marketing resources and capabilities: evidence from the hospitality industry in Taiwan. *Journal of Quality Assurance in Hospitality & Tourism*, 11(4), 219-238. <https://doi.org/10.1080/1528008X.2010.504163>